

2012 APPENDIX B BUILDING CODE SUMMARY FOR ALL COMMERCIAL PROJECTS (EXCEPT 1 AND 2-FAMILY DWELLINGS AND TOWNHOUSES)

Name of Project: US-64 WASHINGTON COUNTY REST AREA RENOVATION/ ADDITION

2012 EDITION OF NC CODE FOR: New Construction Addition Upfit

ALLOWABLE AREA

Primary Occupancy	(A) BLDG AREA PER STORY	(B) TABLE 503 AREA	(C) AREA FOR OPEN SPACE INCREASE	(D) AREA FOR SPRINKLER INCREASE	(E) ALLOWABLE AREA OR UNLIMITED*	(F) MAXIMUM BUILDING AREA**
Business (B)	2,137	9,000	N/A	N/A	9,000	9,000

ALLOWABLE HEIGHT

Type of Construction	Type	Code Reference
Building height in feet	40'	503
Building Height in Stories	2	503

FIRE PROTECTION REQUIREMENTS

Building Element	Fire Separation Distance (Feet)	Req'd (W/R)	Provided (W/R)	Detail #	Design #	Design #	Design #
Structural frame	-	0	0	-	-	-	-
Bearing walls	-	-	-	-	-	-	-
Exterior	-	-	-	-	-	-	-
North	30	0	0	-	-	-	-
East	30	0	0	-	-	-	-
West	30	0	0	-	-	-	-
South	30	0	0	-	-	-	-
Interior	0	0	0	-	-	-	-

LIFE SAFETY SYSTEM REQUIREMENTS

Emergency Lighting:	<input type="checkbox"/> NO	<input checked="" type="checkbox"/> YES
Exit Signs:	<input type="checkbox"/> NO	<input checked="" type="checkbox"/> YES
Fire Alarm:	<input checked="" type="checkbox"/> NO	<input checked="" type="checkbox"/> YES
Smoke Detection Systems:	<input type="checkbox"/> NO	<input checked="" type="checkbox"/> YES
Panic Hardware:	<input checked="" type="checkbox"/> NO	<input checked="" type="checkbox"/> YES

EXIT REQUIREMENTS

FLOOR, ROOM OR SPACE DESIGNATION	MINIMUM # OF EXITS		TRAVEL DISTANCE	EGRESS ARRANGEMENT MEANS OF ESCAPE	
	REQUIRED	SHOWN ON PLANS		REQUIRED BETWEEN EXITS	ACTUAL BETWEEN EXITS
Business	1	2	200'	66"	66"

EXIT WIDTH

USE GROUP OR SPACE DESCRIPTION	AREA		CALCULATED PER OCCUPANT (TABLE 1004.1.1)	EGRESS WIDTH PER OCCUPANT (TABLE 1005.1)		REQUIRED WIDTH (SECTION 1005.1)		ACTUAL WIDTH SHOWN ON PLANS	
	(A) SQ. FT.	(B) PER OCCUPANT (TABLE 1004.1.1)		STAIR	LEVEL	STAIR	LEVEL		
Business	2,137	100	22	N/A	2	N/A	4.4"	N/A	66"

DESIGN LOADS

Importance Factors: Wind (I_w) 1.0, Snow (I_s) 1.0, Seismic (I_e) 1.0

Live Loads: Roof 20 psf, Mezzanine NA psf, Floor 100 psf

SEISMIC DESIGN CATEGORY: II

Occupancy Category: II

Spectral Response Acceleration S_s 15.0 %g, S₁ 6.0 %g

PLUMBING FIXTURE REQUIREMENTS

USE	WATER CLOSETS	URINALS	LABATORIES	SHOWERS/TUBS	DRINKING FOUNTAINS	
	MALE	FEMALE	MALE	FEMALE	REGULAR	ACCESSIBLE
EXISTING	-	-	-	-	-	-
NEW SHOWN	3	5	2	3	3	1
REQUIRED	1	1	0	1	1	1

ACCESSIBLE PARKING / EXISTING PARKING

LOT OR PARKING AREA	TOTAL # OF PARKING SPACES	# OF ACCESSIBLE SPACES PROVIDED	ACCESSIBLE PROVIDED TOTAL #	
			REGULAR WITH 5' ACCESS AISLE	VAN SPACES WITH 8' ACCESS AISLE
22	30	0	2	2

SPECIAL APPROVALS: N/A

ENERGY SUMMARY

COMPONENT NAME / DESCRIPTION	GROSS AREA	CAVITY R-VALUE	CONT. R-VALUE	PROPOSED U-FACTOR	BUDGET U-FACTOR
ROOF 1: INSULATION ENTIRELY ABOVE DECK	3083	---	39.0	0.025	0.048
EXTERIOR WALL 1: WOOD-FRAMED, 16" O.C.	2839	0.0	19.5	0.043	0.088
WINDOW 1: VINYL FRAME, DOUBLE PANE, CLEAR, SHGC 0.81, PF 0.33	140	---	---	0.550	0.650
WINDOW 2: VINYL FRAME, DOUBLE PANE W/LOW-E, CLEAR, SHGC 0.31, PF 0.16	184	---	---	0.290	0.650
DOOR 1: GLASS (550K GLAZING), METAL FRAME, CLEAR, ENTRANCE DOOR, SHGC 0.25, PF 0.43	180	---	---	0.520	0.900
FLOOR 1: UNHEATED, SLAB-ON-GRADE, HORIZ. W/ VERT. INSUL 2FT.	222	---	7.5	---	---

ELECTRICAL SUMMARY: SEE ELECTRICAL

MECHANICAL SUMMARY: SEE MECHANICAL

US-64 REST AREA RENOVATION

REST AREA BUILDING RENOVATION/ ADDITION WASHINGTON COUNTY, NORTH CAROLINA

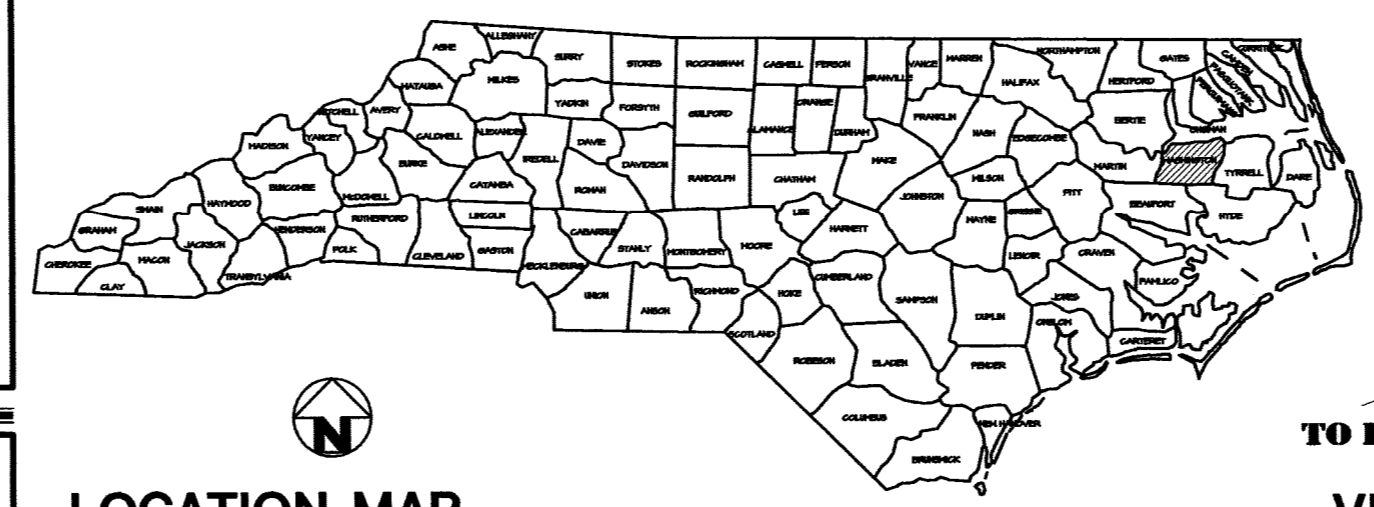

LOCATION MAP

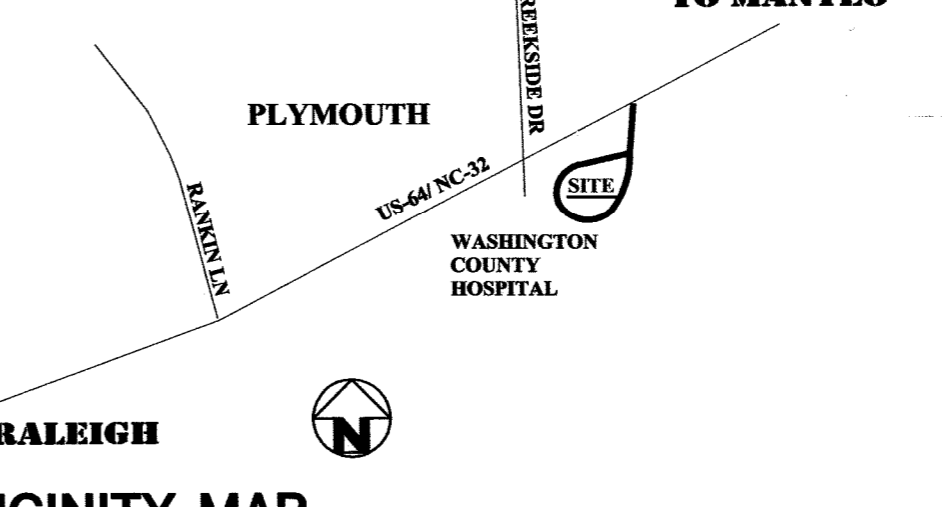

VICINITY MAP

SYMBOLS

SYMBOLS

	SILT FENCE		SPRAY FOAM INSULATION		REVISION NUMBER		BRICK VENEER
	ELEVATION MARK		BATT INSULATION / BLOWN		ELEVATION NUMBER		CONCRETE
	DRAINAGE / SLOPE ARROW		DRYHALL OR PLASTER		DRAWING SHEET NUMBER		STEEL
	EXISTING CONTOURS		GRAVEL		DRAWING NUMBER		ROUGH CARPENTRY
	EXISTING ELEVATION		UNDISTURBED EARTH		DRAWING SHEET REFERENCE NUMBER		BLOCKING
	NEW CONTOURS		COMPACTED FILL		BUILDING OR HALL SECTION NO.		FINISH CARPENTRY
	NEW ELEVATION				DRAWING SHEET NUMBER		
	EXISTING TREE						

ABBREVIATIONS & SYMBOLS

ABBREVIATIONS & SYMBOLS

<	ANGLE	EA	EACH	M.O.	MASONRY OPENING	STL	STEEL
AL	ALUMINUM	EA	EYE WASH	MAT.	MATERIAL	STG.	STORAGE
AB.	ANCHOR BOLT	ELEC.	ELECTRICAL	MAX.	MAXIMUM	S.A.C.	SUSPENDED ACOUSTICAL CEILING
APPROX.	APPROXIMATE	ELEV.	ELEVATION	MIN.	MINIMUM	T&G	TONGUE AND GROOVE
ARCH.	ARCHITECTURAL	EXIST.	EXISTING	HTD.	HOT DRYED	T.O.F.	TOP OF FOOTING
#	AVERAGE	EHC	ELECTRIC WATER COOLER	M.D.G.	MOULDED	T.O.J.	TOP OF JOIST
AT	BACK TO BACK	E/J	EXPANSION JOINT	N.T.S.	NOT TO SCALE	T.O.S.	TOP OF STEEL
BB	BASEMENT	EBG	EXTENDED BOTTOM CHORD	NO.	NUMBER	T.O.W.	TOP OF WALL
B&MT.	BEARING	EXT.	EXTERIOR	O.C.	ON CENTER	T.	TREAD
BRG.	BENCH MARK	FFF	FINISH FLOOR ELEVATION	O.G.	OPENING	TYP.	TYPICAL
BLK.S	BLOCKING	FIN.F.	FINISH FLOOR	OF.N.	OPENING	UNF.	UNFINISHED
BD.	BOARD	F.F.	FIRE EXTINGUISHER	PNL	PANEL	UNF.N.	UNFINISHED
BLDG.	BUILDING	F.D.	FLOOR DRAIN	FLAS/PL.	FLASHPLASTIC LAMINATE	VERT.	VERTICAL
CH	CEILING HEIGHT	F.F.F.	FINISH FLOOR FINISH	PLATE	PLATE	WELDED WIRE MESH	
C.L.	CENTER LINE	FRSHB	FIRE RATED GYPSUM HALLBOARD	F.L.M.B.	FLUMING	W/	WITH
C.G.	CENTER TO CENTER	GALV.	GALVANIZED	FLYND.	PLYWOOD	WD.	WOOD
C.I.	CAST IRON	GA.	GAUGE	LB(9)	POUND	W/	WITH
COL.	COLUMN	GL.	GLASS	PREFAB.	PREFABRICATED	MD.	MATERIAL
CONC.	CONCRETE	GP.	GRAZED PAVET TILE	P.F.S.I.	POUNDS PER SQUARE INCH	H.M.M.	HOLLOW METAL MESH
CONC.	CONCRETE MASONRY UNIT	GRP.	GYPSUM SHEATHING	REGID.	REQUIRED	W.	WITH
CONT.	CONTINUOUS	GYP.	GYPSUM	RISER	RISER	MD.	MATERIAL
CJ	CEILING JOIST	H.R.	HOLLOW METAL	RISER	RISER	H.	HORIZONTAL
C/J	CONSTRUCTION JOINT	HR.	HORIZONTAL	RISER	RISER	H.	HORIZONTAL
CRS	COURSES	H.B.	HOSE BIBB	REQD	REQUIRED	H.	HORIZONTAL
DET.	DETAIL	INSUL.	INSULATION	RISER	RISER	H.	HORIZONTAL
DIA.	DIAMETER	INT.	INTERIOR	RISER	RISER	H.	HORIZONTAL
		JST.	JOIST	RISER	RISER	H.	HORIZONTAL
		LAV.	LAVATORY	RISER	RISER	H.	HORIZONTAL
		M.H.	MAN HOLE	RISER	RISER	H.	HORIZONTAL

DRAWING SHEET INDEX

- T1 BUILDING CODE SUMMARY & TITLE SHEET
- SITE DEVELOPMENT
 - L1.0 TITLE, DESCRIPTION, LOCATION
 - L2.0 PROPOSED SITE PLAN
 - L3.0 EXISTING SITE PLAN
 - L4.0 DEMOLITION PLAN
 - L5.0 LAYOUT PLAN
 - L6.0 GRADING PLAN
 - L7.0 DETAILS
 - L8.0 DETAILS
- ARCHITECTURAL
 - A1 DEMOLITION PLAN & NOTES
 - A2 FLOOR PLAN
 - A3 ROOF PLAN, DETAILS
 - A4 REFLECTED CEILING PLAN, DETAILS
 - A5 EXTERIOR ELEVATIONS
 - A6 BUILDING SECTIONS
 - A7 HALL SECTIONS & DETAILS
 - A8 INTERIOR ELEVATIONS & DETAILS
 - A9 INTERIOR ELEVATIONS & DETAILS, ROOM FINISH SCHEDULE
 - A10 INTERIOR ELEVATIONS
 - A11 INTERIOR ELEVATIONS, FLOOR TILE PATTERNS
 - A12 DOOR & WINDOW SCHEDULES, DETAILS
- STRUCTURAL
 - S1 FOUNDATION PLAN & DETAILS
 - S2 ROOF FRAMING PLAN & DETAILS
 - S3 BUILDING FRAME SCHEMATICS, LINTELS & DETAILS
 - S4 DETAILS
- PLUMBING
 - P1 FIXTURE SCHEDULE & DETAILS
 - P2 DRAIN/WASTE/VENT PLAN
 - P3 SUPPLY PLAN
 - P3 SOLAR WATER HEATER DETAILS
- MECHANICAL
 - M1 HVAC SCHEDULES
 - M2 HVAC PLAN
- ELECTRICAL
 - E1 NOTES, DETAILS & SPECIFICATIONS
 - E2 LIGHTING PLAN & ENERGY CODE
 - E3 POWER PLAN, SCHEDULES & RISERS
- U1 UTILITIES SITE PLAN
- U2 UTILITIES NOTES & DETAILS

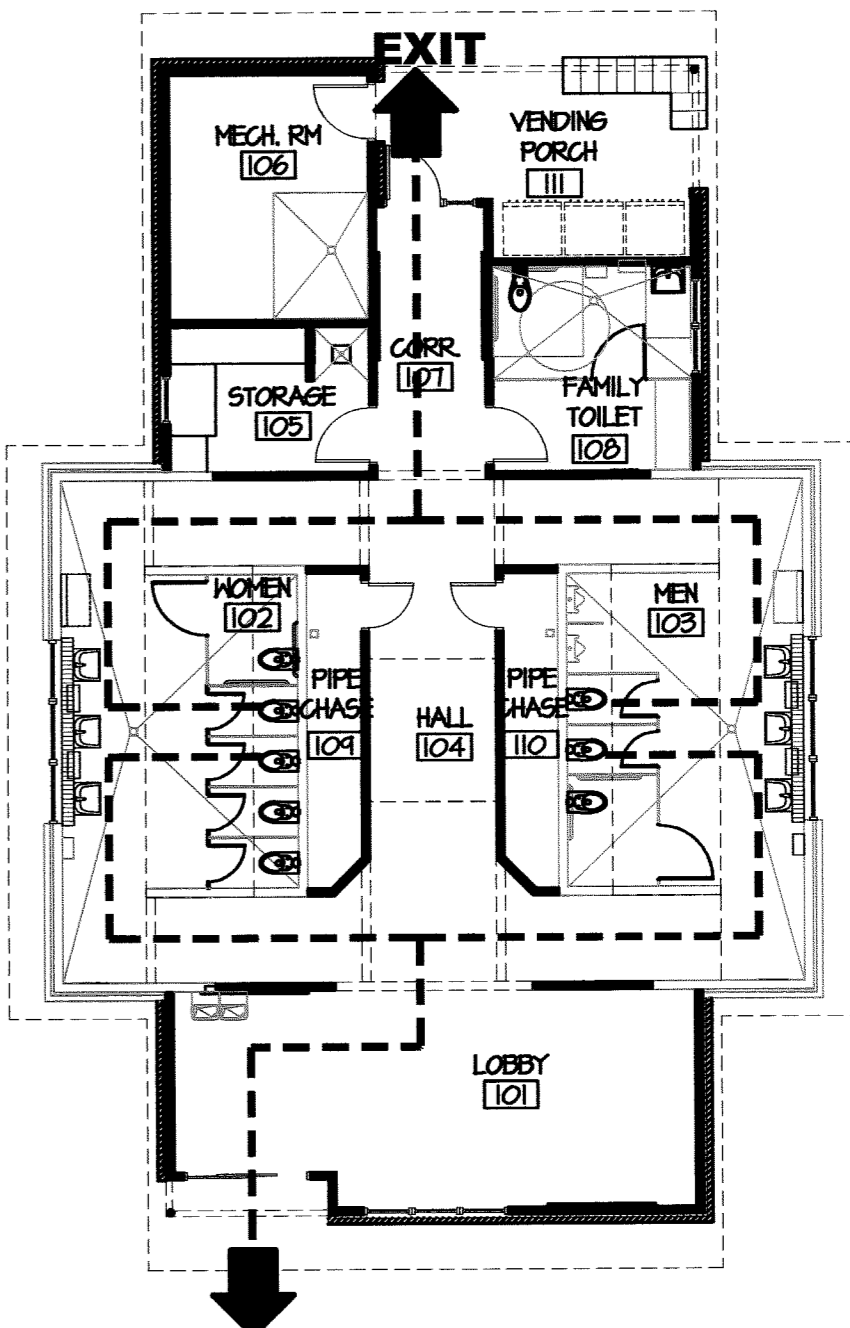

EXIT EGRESS PLAN
SCALE: 3/32" = 1'-0"

Washington County US-64 Rest Area/ Visitor Center
1248 US-64 EAST, PLYMOUTH, NC 27962

FACILITIES DESIGN ARCHITECTS & ENGINEERS
FACILITIES MANAGEMENT DIVISION, NCDOT
1 SOUTH WILMINGTON STREET, RALEIGH, NORTH CAROLINA 27601

TIP PROJ. NO. K-5000
WBS NO. 41532.3.1
CONTRACT ID NO.
FEDERAL ID NO. NWS-0084(158)
REVISIONS

DATE ISSUED: 10/9/12
DRAWN BY: AS
CHECKED BY: VB
SHEET NO. **T1**
1 OF 1

PROJECT: US 64 Washington County Rest Area Renovation



HIGHWAY LANDSCAPE DEVELOPMENT PROJECT



T.I.P. #	STATE PROJECT W.B.S. #	SHEET #	SHEET # TOTAL
K-5000	41532.3.1	L1.0	8
FED. PROJ. #	DESCRIPTION		DIVISION
-	RA Renovation		1

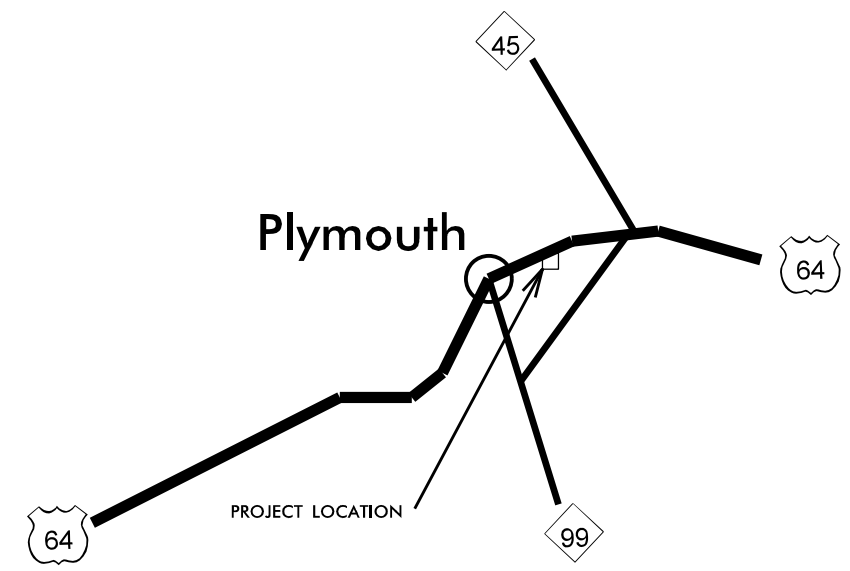
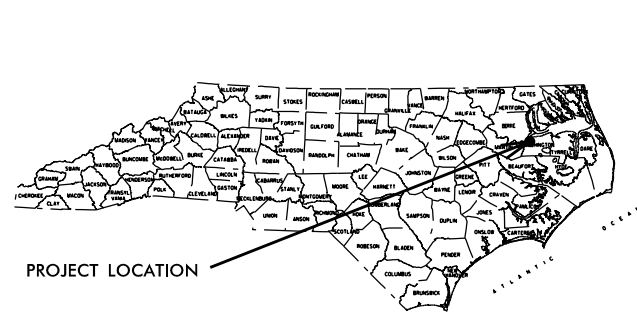

Summary of Quantities

Pay Item	Description	Unit	Quantity
6975000000	Site Demolition	LS	1
6147000000	Tree Preservation / Protection Fence	LF	100
2591000000	4" Concrete Sidewalk	SY	400
6975000000	Landscape and Site Grading	LS	1
6900000000	Topsoil	CY	50
6975000000	Site Stormwater Drainage	LS	1
2761000000	9" Concrete Border	SY	18
6975000000	3" PVC Sleeve	LF	90
6975000000	Permeable Interlocking Concrete Pavers	SF	1210
6970000000	5' Bench with Brick Base	EA	8
6975000000	Relocate Post Top Light	EA	1
6975000000	Relocate Telephone Pedestal	EA	1
2605000000	Concrete Curb Ramp	EA	3

CONVENTIONAL SYMBOLS

County Line
City or Town Line	-----
Exist. Right of Way Line Marker	-----▲-----
Prop. Right of Way Line Marker (By Others)	-----▲-----
Prop Right of Way Line Marker (By Contract)	-----▲-----
Exist. Control of Access Line	-----⊕-----
Prop. Control of Access Line	-----⊕-----
Property Line	-----○-----
Easement Line	-----○-----
Slope Stake Line	-----○-----
Exist. Fence	-----+-----
Prop. Woven Wire Fence	-----+-----
Prop. Chain Link Fence	-----+-----
Exist. Road	-----+-----
Prop. Road	-----+-----
Guardrail	-----+-----
Survey Line	-----+-----
Denotes Line Equality	-----+-----
Bridge	-----+-----
Culvert	-----+-----
Railroad	-----+-----
Woods	-----+-----
Exist. Telephone Pole	-----+-----
Prop. Telephone Pole	-----+-----
Tower Pole and Line	-----+-----
Exist. Power Pole	-----+-----
Prop. Power Pole	-----+-----
Sanitary Sewer Line	-----+-----
Water Line	-----+-----
Gas Line	-----+-----
Picnic Shelter	-----+-----
Regeneration	-----+-----
Reforestation	-----+-----

INDEX OF L SHEETS:

L 1.0	... TITLE, DESCRIPTION, LOCATION
L 2.0	... PROPOSED SITE PLAN
L 3.0	... EXISTING SITE PLAN
L 4.0	... DEMOLITION PLAN
L 5.0	... LAYOUT PLAN
L 6.0	... GRADING PLAN
L 7.0	... DETAILS
L 8.0	... DETAILS

PREPARED BY: DLW DATE: 12/2012
REVISIONS

DATE	DESCRIPTION



STATE OF NORTH CAROLINA
DEPARTMENT OF TRANSPORTATION



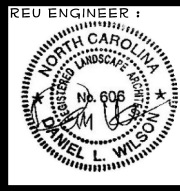



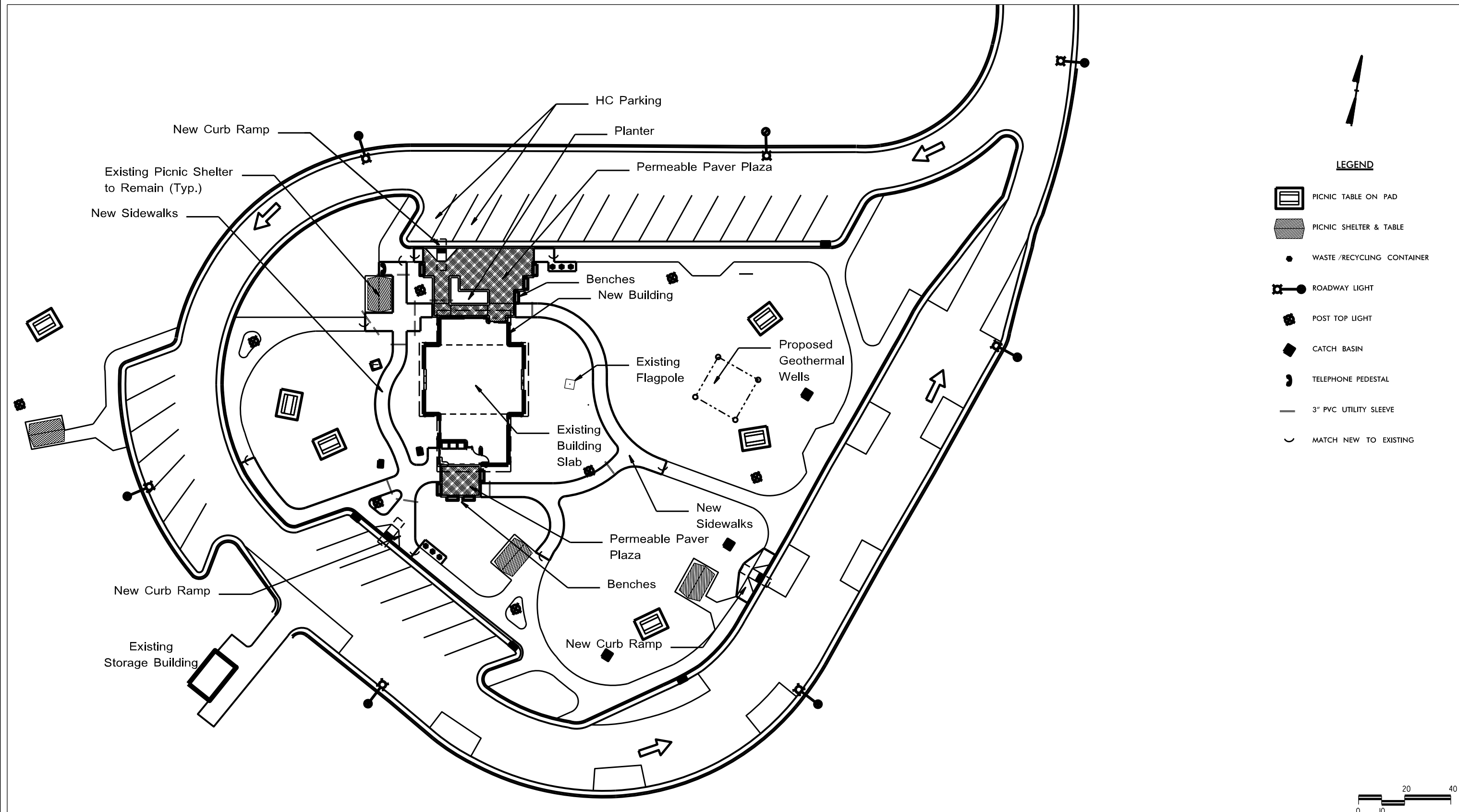

LOCATION: US 64 Rest Area Plymouth
TYPE of WORK: Rest Area Renovation
COUNTY: Washington County



2004 American Standard for Nursery Stock
2012 NCDOT STANDARD SPECIFICATIONS
PREPARED IN THE OFFICE OF:
NCDOT- ROADSIDE ENVIRONMENTAL UNIT
LANDSCAPE DESIGN & DEVELOPMENT SECTION
1557 MAIL SERVICE CENTER
RALEIGH NC 27699 919-707-2920



LEGEND

-  PICNIC TABLE ON PAD
-  PICNIC SHELTER & TABLE
-  WASTE /RECYCLING CONTAINER
-  ROADWAY LIGHT
-  POST TOP LIGHT
-  CATCH BASIN
-  TELEPHONE PEDESTAL
-  3" PVC UTILITY SLEEVE
-  MATCH NEW TO EXISTING



NCDOT - ROADSIDE ENVIRONMENTAL UNIT
 LANDSCAPE DESIGN & DEVELOPMENT
 1557 MAIL SERVICE CENTER, RALEIGH, NC 27699-1557
 PH: 919-707-2920 FAX: 919-715-2554
[HTTP://WWW.NCDOT.ORG/DOH/OPERATIONS/DP_CHIEF_ENG/ROADSIDE/](http://www.ncdot.org/DOH/OPERATIONS/DP_CHIEF_ENG/ROADSIDE/)

**US 64 Washington County
 Rest Area Renovation**
W0601 41532.3.1

REV ENGINEER :



SHEET DESCRIPTION:	
	Proposed Site Plan

PREL DESIGN DATE:	11 / 8 / 2012
CHECKED BY & DATE:	
FINAL DESIGN DATE:	12 / 18 / 2012





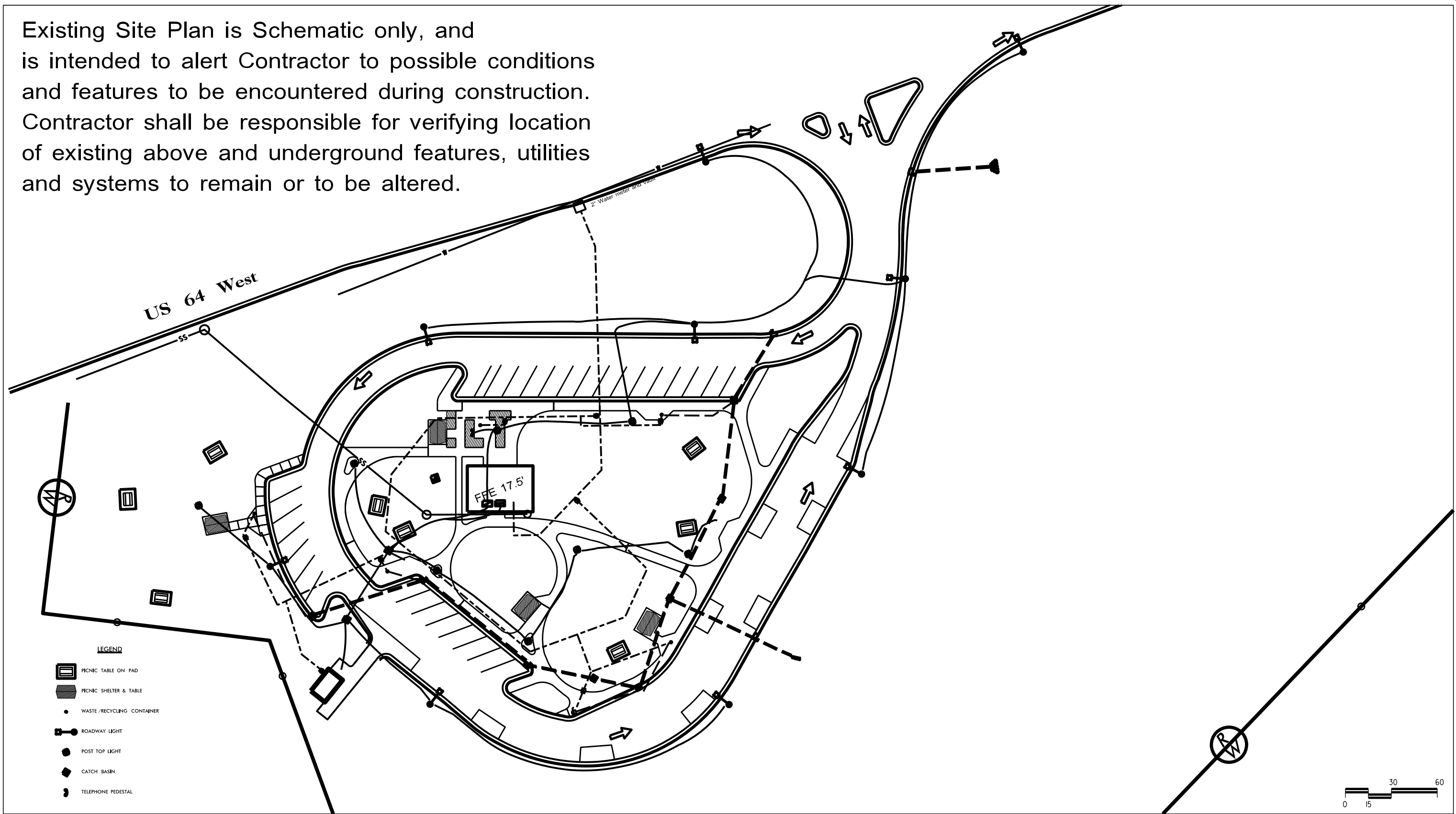

SHEET NO: **2.0**
 TOTAL SHEET NO: **8**

Existing Site Plan is Schematic only, and is intended to alert Contractor to possible conditions and features to be encountered during construction. Contractor shall be responsible for verifying location of existing above and underground features, utilities and systems to remain or to be altered.



LEGEND

-  PICNIC TABLE ON PAD
-  PICNIC SHELTER & TABLE
-  WASTE / RECYCLING CONTAINER
-  ROADWAY LIGHT
-  POST TOP LIGHT
-  CATCH BASIN
-  TELEPHONE PEDESTAL

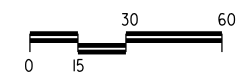

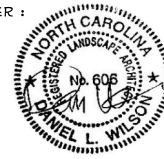
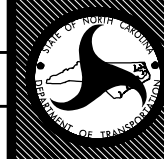
	NCDOT - ROADSIDE ENVIRONMENTAL UNIT LANDSCAPE DESIGN & DEVELOPMENT 1557 MAIL SERVICE CENTER, RALEIGH, NC 27699-1557 PH: 919-707-2920 FAX: 919-715-2554 HTTP://WWW.NCDOT.ORG/DOH/OPERATIONS/DP_CHIEF_ENG/ROADSIDE/	US 64 Washington County Rest Area Renovation W0601 41532.3.1	REV ENGINEER : 	SHEET DESCRIPTION: Existing Site Plan	PREL DESIGN DATE: 11 / 8 / 2012 CHECKED BY & DATE : FINAL DESIGN DATE: 12 / 18 / 2012		SHEET NO : 13.0 TOTAL SHEET NO : 8
---	--	---	---	---	---	---	---

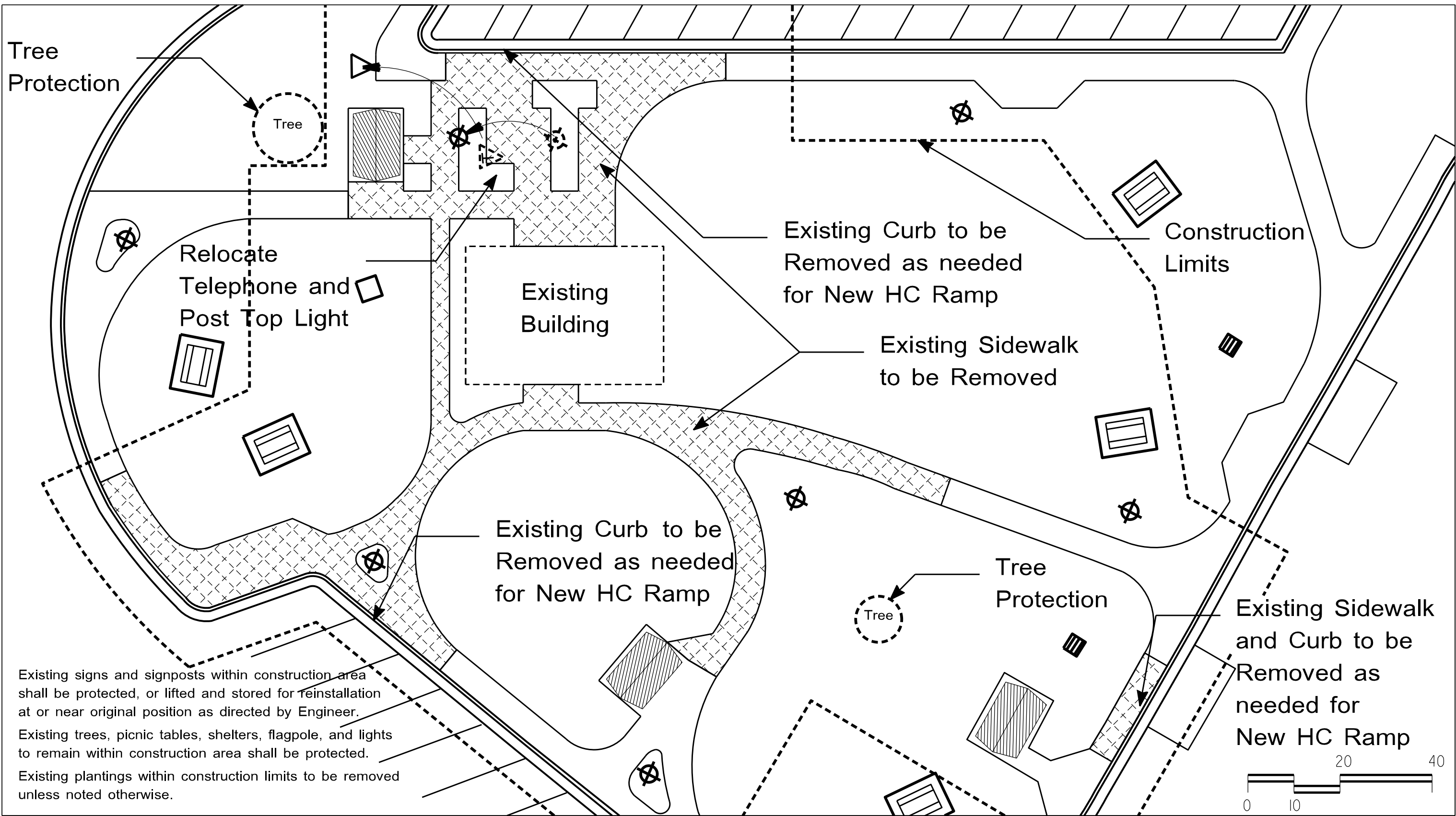

Existing signs and signposts within construction area shall be protected, or lifted and stored for reinstallation at or near original position as directed by Engineer.

Existing trees, picnic tables, shelters, flagpole, and lights to remain within construction area shall be protected.

Existing plantings within construction limits to be removed unless noted otherwise.



NCDOT - ROADSIDE ENVIRONMENTAL UNIT
 LANDSCAPE DESIGN & DEVELOPMENT
 1557 MAIL SERVICE CENTER, RALEIGH, NC 27699-1557
 PH: 919-707-2920 FAX: 919-715-2554
[HTTP://WWW.NCDOT.ORG/DOH/OPERATIONS/DP_CHIEF_ENG/ROADSIDE/](http://www.ncdot.org/DOH/OPERATIONS/DP_CHIEF_ENG/ROADSIDE/)

**US 64 Washington County
 Rest Area Renovation**
W0601 41532.3.1

REV ENGINEER :

SHEET DESCRIPTION:	PREL DESIGN DATE: 11 / 8 / 2012
	CHECKED BY & DATE:
	FINAL DESIGN DATE: 12 / 18 / 2012

PREL DESIGN DATE: 11 / 8 / 2012
 CHECKED BY & DATE:
 FINAL DESIGN DATE: 12 / 18 / 2012



SHEET NO: **4.0**
 TOTAL SHEET NO: **8**

Demolition Plan

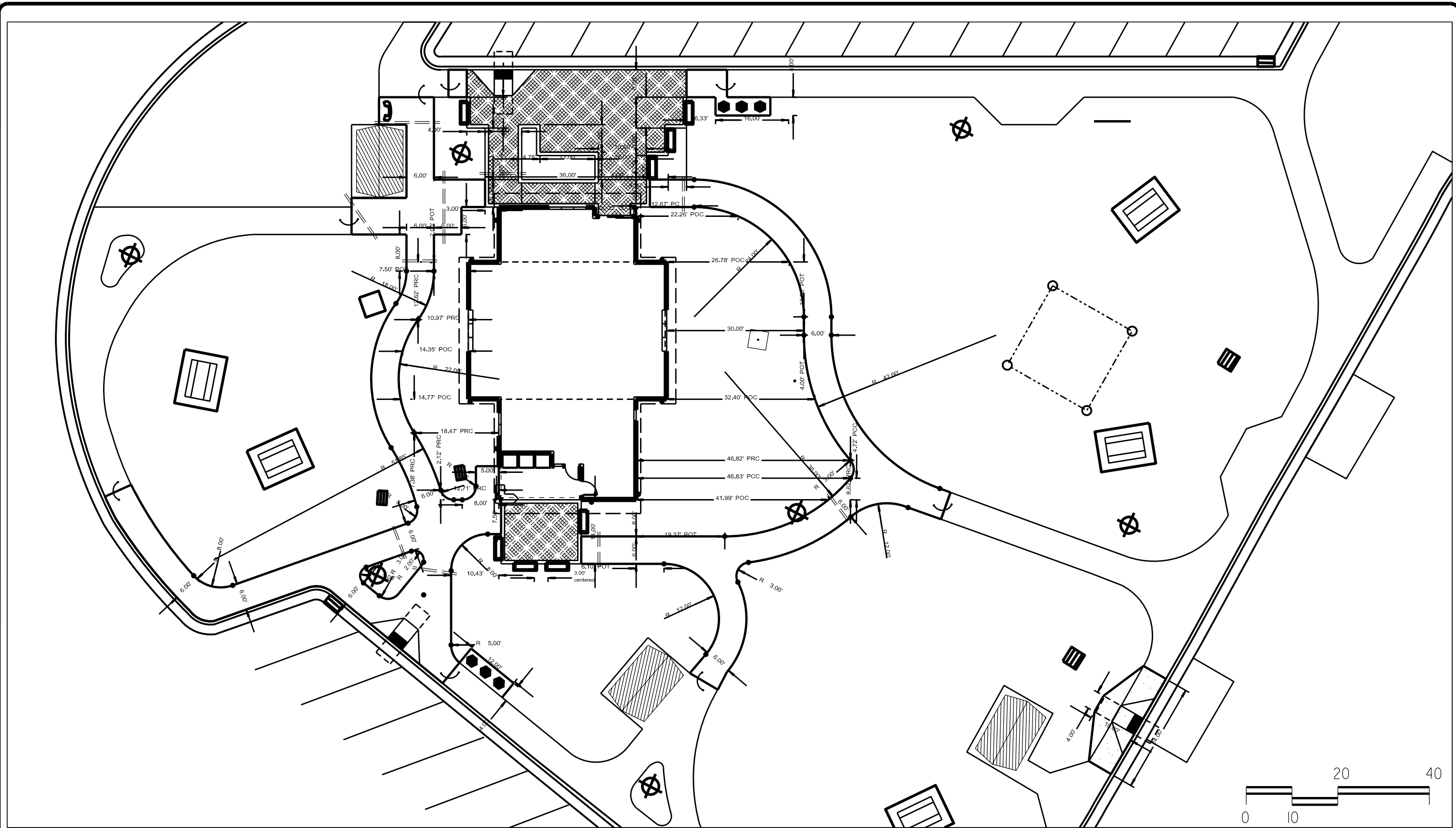

NCDOT - ROADSIDE ENVIRONMENTAL UNIT
 LANDSCAPE DESIGN & DEVELOPMENT
 1557 MAIL SERVICE CENTER, RALEIGH, NC 27699-1557
 PH: 919-707-2920 FAX: 919-715-2554
[HTTP://WWW.NCDOT.ORG/DOH/OPERATIONS/DP_CHIEF_ENG/ROADSIDE/](http://www.ncdot.org/DOH/OPERATIONS/DP_CHIEF_ENG/ROADSIDE/)

**US 64 Washington County
 Rest Area Renovation**
W0601 41532.3.1

REV ENGINEER :

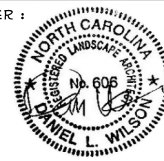

SHEET DESCRIPTION:

Layout Plan

PREL DESIGN DATE: **11 / 8 / 2012**
 CHECKED BY & DATE:
 FINAL DESIGN DATE: **12 / 18 / 2012**

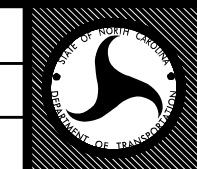

SHEET NO: **5.0**
 TOTAL SHEET NO: **8**

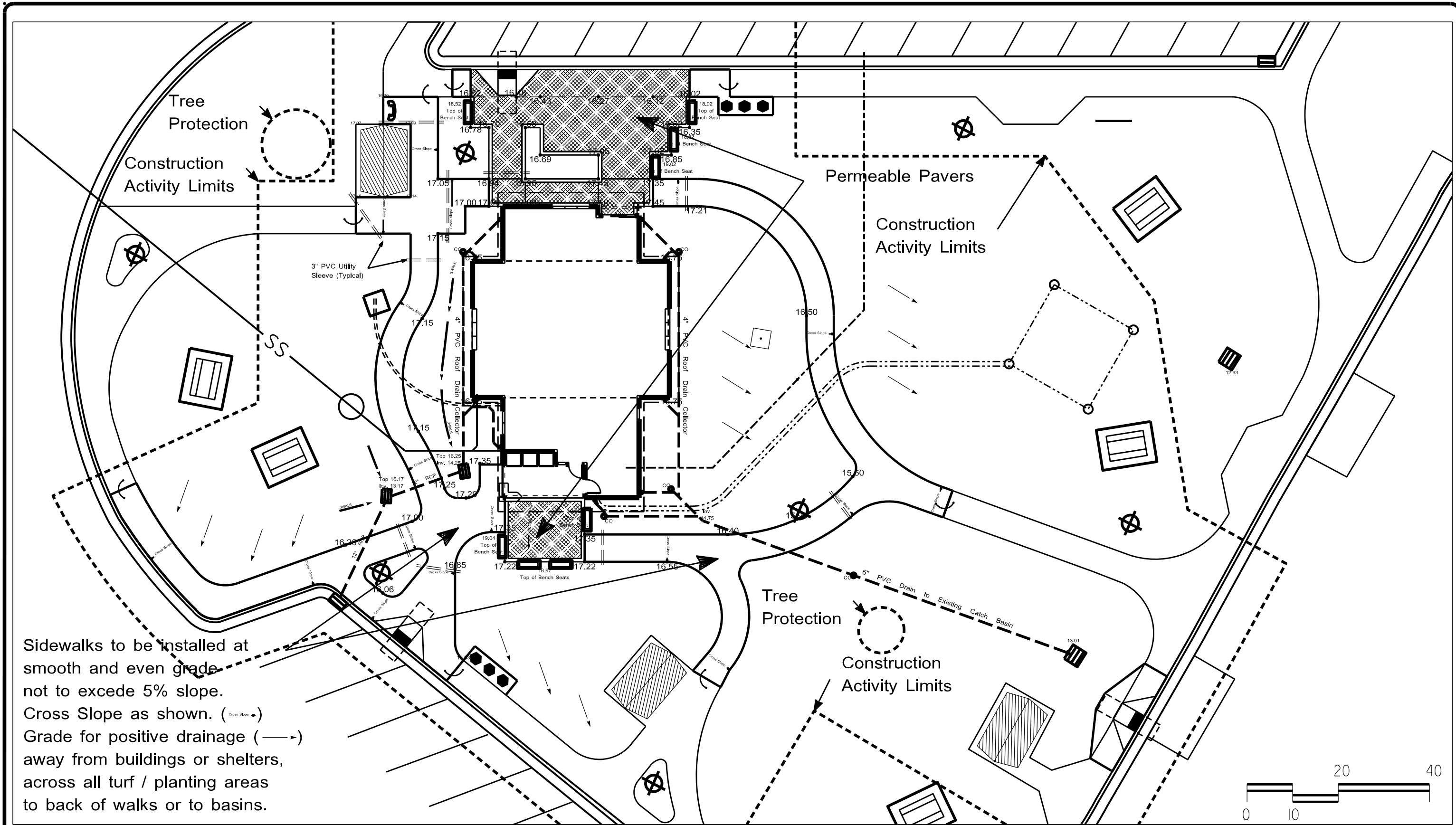

Sidewalks to be installed at smooth and even grade not to exceed 5% slope. Cross Slope as shown. (→) Grade for positive drainage away from buildings or shelters, across all turf / planting areas to back of walks or to basins.

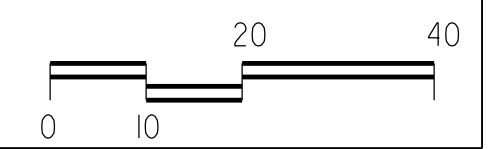

	NCDOT - ROADSIDE ENVIRONMENTAL UNIT LANDSCAPE DESIGN & DEVELOPMENT 1557 MAIL SERVICE CENTER, RALEIGH, NC 27699-1557 PH: 919-707-2920 FAX: 919-715-2554 HTTP://WWW.NCDOT.ORG/DOH/OPERATIONS/DP_CHIEF_ENG/ROADSIDE/	US 64 Washington County Rest Area Renovation W0601 41532.3.1	REV ENGINEER : 	PREL DESIGN DATE: 11 / 8 / 2012 CHECKED BY & DATE : FINAL DESIGN DATE: 12 / 18 / 2012	SHEET NO : 6.0 TOTAL SHEET NO : 8
	Grading and Drainage Plan				

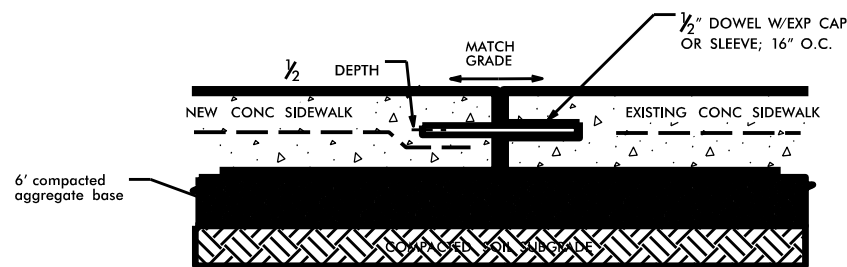

D2
L 7.0
MATCHING NEW CONCRETE SIDEWALK TO EXISTING SIDEWALK
nts

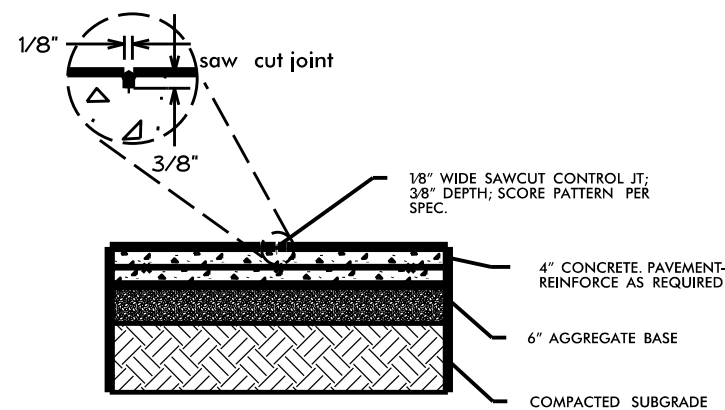

D1
L 7.0
CONCRETE SIDEWALK - CONTROL JOINT
nts

GENERAL NOTES:

- 1) Standard 4" THICK CONCRETE SIDEWALK to be installed as noted on plans; Control joint every 5' (or same dimension as sidewalk width) and Expansion joint every 30' (and where the sidewalk adjoins another hard surface).
- 2) CONCRETE PAVER BORDER as shown on plans:
- 9" cast in place curb or
- metal restraint as spec'd.
- 3) Paver pattern, color, and dimensions as defined in plans, details, or specifications.
- 4) All hardscape surfaces shall be graded properly to drain to landscape areas, curbs, or drop inlets.
- 5) Where permeable pavers are installed, complete control of construction practices are vital. No debris, soil, or unspecified material shall come in to contact (or be layed upon) the completed surface or compromise installed drainage layers.

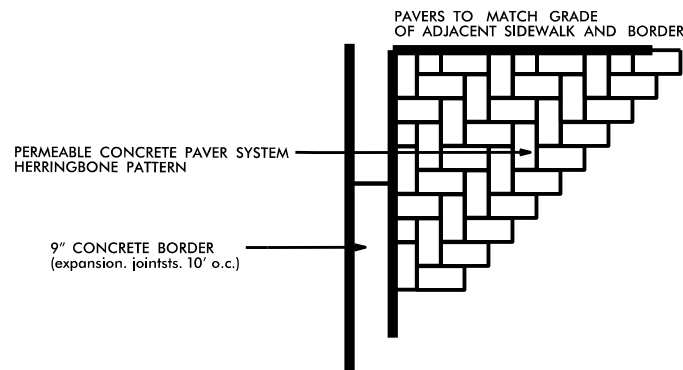

D3
L 7.0
TYPICAL PAVER PATTERN
nts

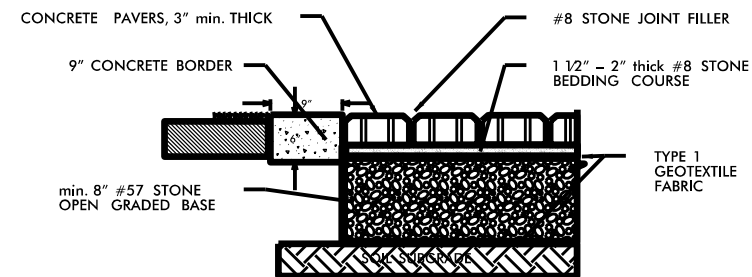

D4
L 7.0
PERMEABLE INTERLOCKING CONCRETE PAVER DETAIL
Pedestrian and Light Utility Traffic Area
nts

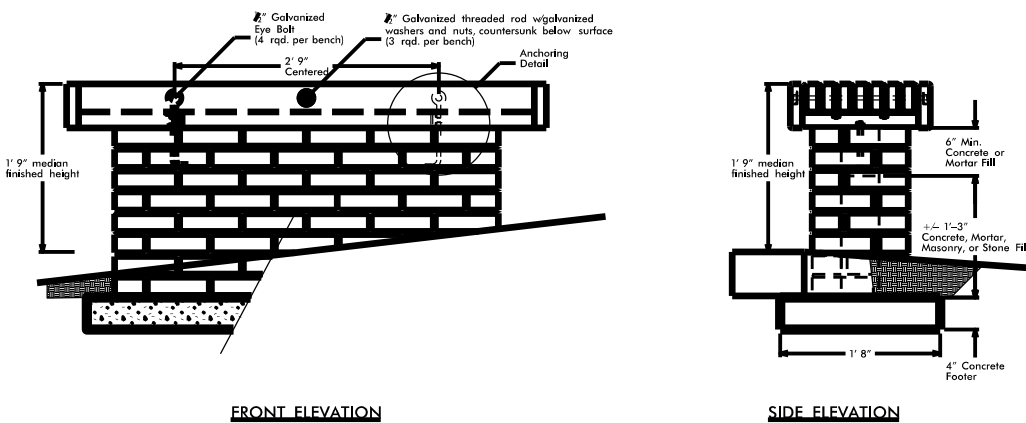
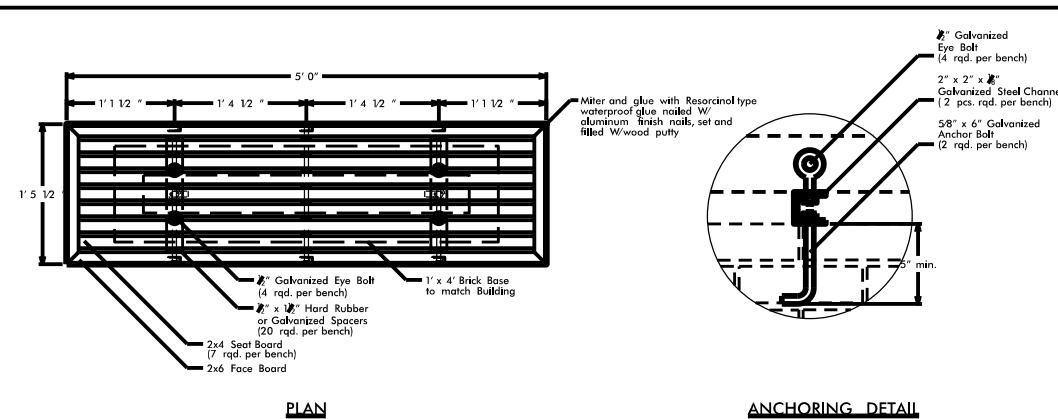

D5
L 7.0
BENCH WITH BRICK BASE
nts



NCDOT - ROADSIDE ENVIRONMENTAL UNIT
LANDSCAPE DESIGN & DEVELOPMENT
1557 MAIL SERVICE CENTER, RALEIGH, NC 27699-1557
PH: 919-707-2920 FAX: 919-715-2554
HTTP://WWW.NCDOT.ORG/DOH/OPERATIONS/DP_CHIEF_ENG/ROADSIDE/

**US 64 Washington County
Rest Area Renovation**
W060: 41532.3.1

REU ENGINEER :



SHEET DESCRIPTION:	PREL DESIGN DATE: 11/8/2012
	CHECKED BY & DATE:
	FINAL DESIGN DATE: 12/18/2012

PREL DESIGN DATE: 11/8/2012
CHECKED BY & DATE:
FINAL DESIGN DATE: 12/18/2012

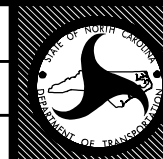

SHEET NO: L 7.0
TOTAL SHEET NO: 8

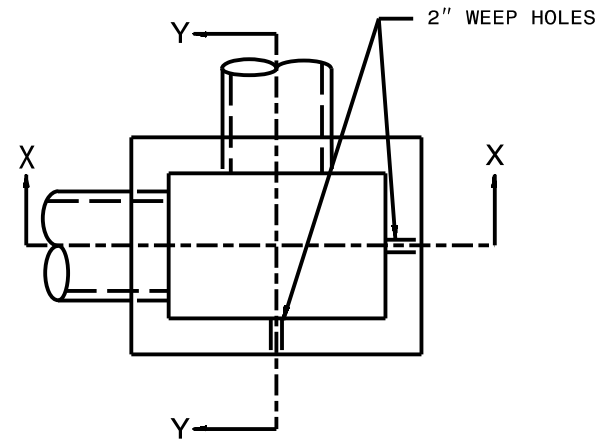

PLAN

WITH GRATE & FRAME REMOVED

GENERAL NOTES:
 USE CLASS "B" CONCRETE THROUGHOUT.
 PROVIDE ALL DROP INLETS OVER 3'-6" IN DEPTH WITH STEPS 12" ON CENTER. USE STEPS WHICH COMPLY WITH STD. DRAWING 840.66.
 OPTIONAL CONSTRUCTION - MONOLITHIC POUR 2" KEYWAY OR #4 BAR DOWELS AT 12" CENTERS AS DIRECTED BY THE ENGINEER.
 USE FORMS FOR THE CONSTRUCTION OF THE BOTTOM SLAB.
 IF REINFORCED CONCRETE PIPE IS SET IN BOTTOM SLAB OF BOX, ADD TO SLAB AS SHOWN ON STD. NO. 840.00.
 CONSTRUCT WITH PIPE CROWNS MATCHING.
 INSTALL 2" WEEPHOLES AS DIRECTED BY THE ENGINEER.
 INSTALL STONE DRAINS, OF A MINIMUM OF 1 CUBIC FOOT OF NO. 78M STONE IN A POROUS FABRIC BAG OR WRAP, AT EACH WEEP HOLE OR AS DIRECTED BY THE ENGINEER.
 CHAMFER ALL EXPOSED CORNERS 1".
 DRAWING NOT TO SCALE.

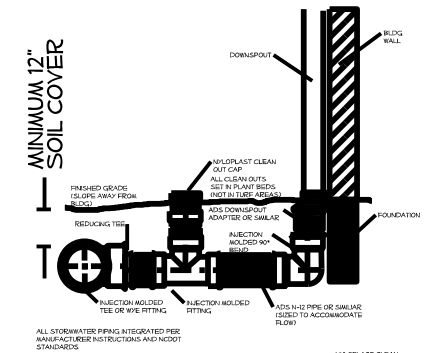

Alternate with Cleanout at End of Line

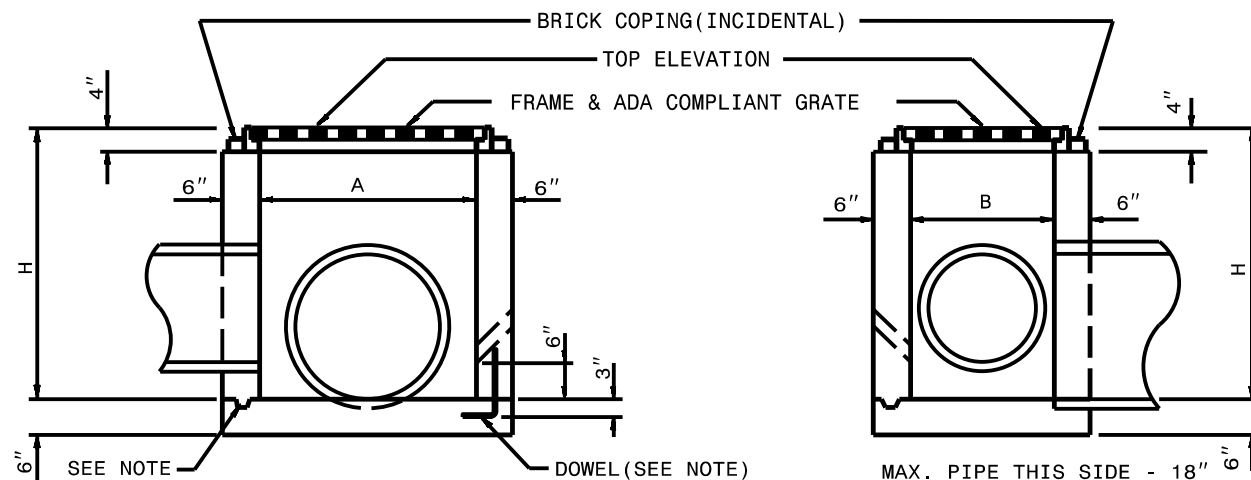

SECTION X-X

SECTION Y-Y

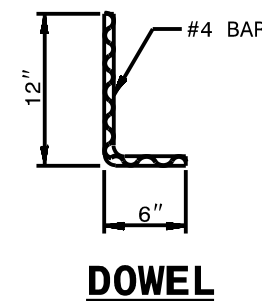

DOWEL

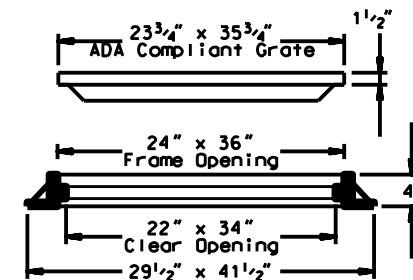

FRAME & ADA COMPLIANT GRATE

Examples: East Jordan Iron Works, Inc. V-5660**
 U.S. Foundry & Mfg. Corp. 4139 Frame & 6002 Grate

DIMENSIONS AND QUANTITIES FOR DROP INLET (BASED ON MIN. HEIGHT, H)								
DIMENSIONS OF BOX & PIPE				CUBIC YARDS CONC. IN BOX			DEDUCTIONS FOR ONE PIPE	
PIPE	SPAN	WIDTH	MIN. HEIGHT	BOTTOM SLAB	WALL PER FT. HT.	TOTAL CONCRETE FOR MINIMUM HEIGHT, H	C.M.	R.C.
12"	3'-0"	2'-0"	2'-0"	0.222	0.222	0.592	0.015	0.026
15"	/	/	2'-3"	/	/	0.648	0.023	0.036
18"	/	/	2'-6"	/	/	0.703	0.033	0.049
24"	/	/	3'-0"	/	/	0.814	0.059	0.085
30"	3'-0"	2'-0"	3'-6"	0.222	0.222	0.925	0.092	0.127

ROOF LEADER CONNECTION

SCALE: NTS



NCDOT - ROADSIDE ENVIRONMENTAL UNIT
 LANDSCAPE DESIGN & DEVELOPMENT
 1557 MAIL SERVICE CENTER, RALEIGH, NC 27699-1557
 PH: 919-707-2920 FAX: 919-715-2554
 HTTP://WWW.NCDOT.ORG/DOH/OPERATIONS/DP_CHIEF_ENG/ROADSIDE/

**US 64 Washington County
 Rest Area Renovation**
W060: 41532.3.1

REV ENGINEER :

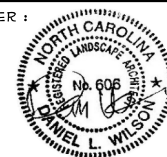

Roof Leader Connection
Concrete Drop Inlet

PREL DESIGN DATE: 11 / 8 / 2012
 CHECKED BY & DATE:
 FINAL DESIGN DATE: 12 / 18 / 2012



SHEET NO: **L 8.0**
 TOTAL SHEET NO: **8**

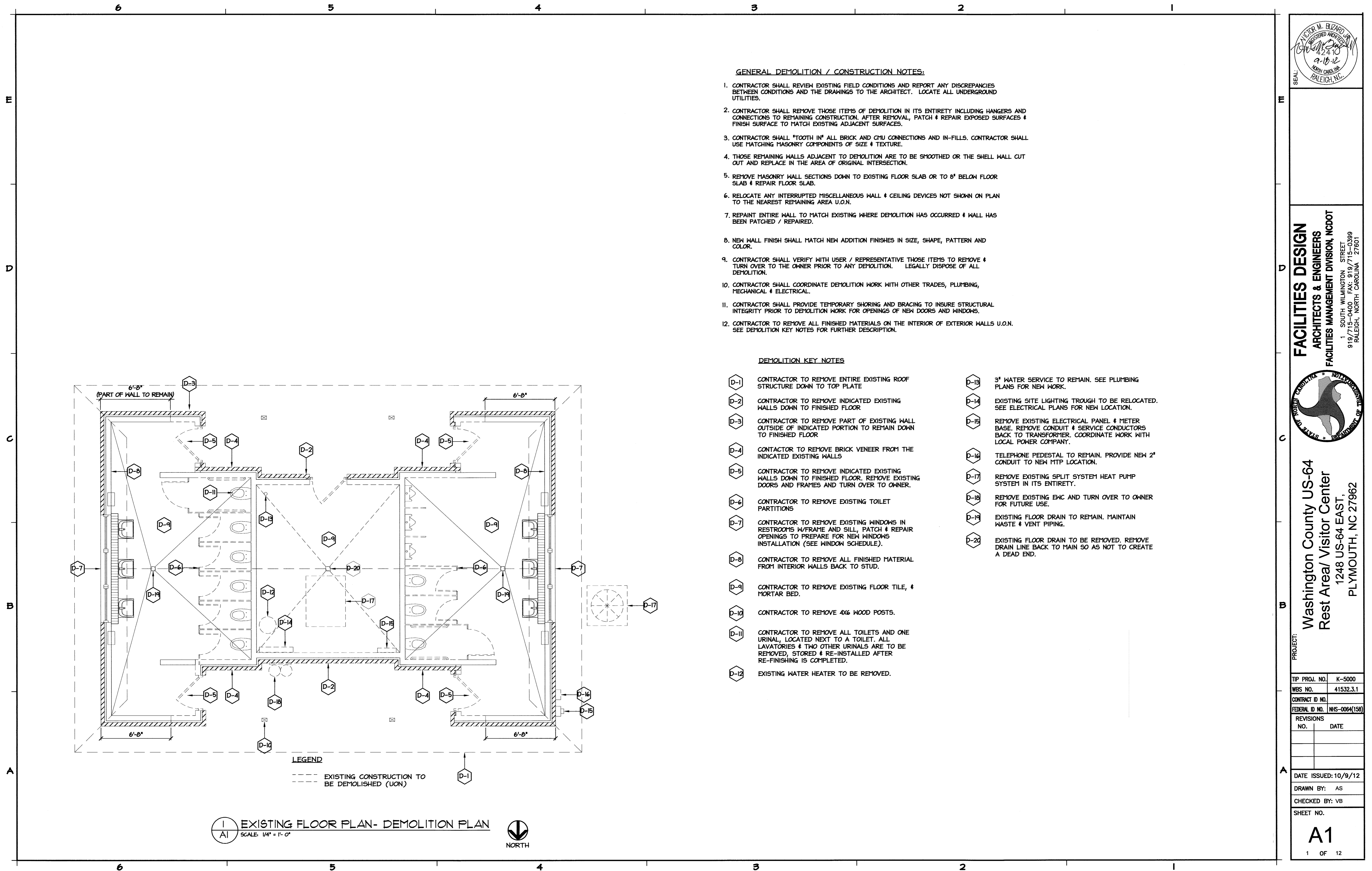

GENERAL DEMOLITION / CONSTRUCTION NOTES:

1. CONTRACTOR SHALL REVIEW EXISTING FIELD CONDITIONS AND REPORT ANY DISCREPANCIES BETWEEN CONDITIONS AND THE DRAWINGS TO THE ARCHITECT. LOCATE ALL UNDERGROUND UTILITIES.
2. CONTRACTOR SHALL REMOVE THOSE ITEMS OF DEMOLITION IN ITS ENTIRETY INCLUDING HANGERS AND CONNECTIONS TO REMAINING CONSTRUCTION. AFTER REMOVAL, PATCH & REPAIR EXPOSED SURFACES & FINISH SURFACE TO MATCH EXISTING ADJACENT SURFACES.
3. CONTRACTOR SHALL "TOOTH IN" ALL BRICK AND CMU CONNECTIONS AND IN-FILLS. CONTRACTOR SHALL USE MATCHING MASONRY COMPONENTS OF SIZE & TEXTURE.
4. THOSE REMAINING WALLS ADJACENT TO DEMOLITION ARE TO BE SMOOTHED OR THE SHELL WALL CUT OUT AND REPLACE IN THE AREA OF ORIGINAL INTERSECTION.
5. REMOVE MASONRY WALL SECTIONS DOWN TO EXISTING FLOOR SLAB OR TO 8" BELOW FLOOR SLAB & REPAIR FLOOR SLAB.
6. RELOCATE ANY INTERRUPTED MISCELLANEOUS WALL & CEILING DEVICES NOT SHOWN ON PLAN TO THE NEAREST REMAINING AREA U.O.N.
7. REPAINT ENTIRE WALL TO MATCH EXISTING WHERE DEMOLITION HAS OCCURRED & WALL HAS BEEN PATCHED / REPAIRED.
8. NEW WALL FINISH SHALL MATCH NEW ADDITION FINISHES IN SIZE, SHAPE, PATTERN AND COLOR.
9. CONTRACTOR SHALL VERIFY WITH USER / REPRESENTATIVE THOSE ITEMS TO REMOVE & TURN OVER TO THE OWNER PRIOR TO ANY DEMOLITION. LEGALLY DISPOSE OF ALL DEMOLITION.
10. CONTRACTOR SHALL COORDINATE DEMOLITION WORK WITH OTHER TRADES, PLUMBING, MECHANICAL & ELECTRICAL.
11. CONTRACTOR SHALL PROVIDE TEMPORARY SHORING AND BRACING TO INSURE STRUCTURAL INTEGRITY PRIOR TO DEMOLITION WORK FOR OPENINGS OF NEW DOORS AND WINDOWS.
12. CONTRACTOR TO REMOVE ALL FINISHED MATERIALS ON THE INTERIOR OF EXTERIOR WALLS U.O.N. SEE DEMOLITION KEY NOTES FOR FURTHER DESCRIPTION.

DEMOLITION KEY NOTES

- D-1 CONTRACTOR TO REMOVE ENTIRE EXISTING ROOF STRUCTURE DOWN TO TOP PLATE
- D-2 CONTRACTOR TO REMOVE INDICATED EXISTING WALLS DOWN TO FINISHED FLOOR
- D-3 CONTRACTOR TO REMOVE PART OF EXISTING WALL OUTSIDE OF INDICATED PORTION TO REMAIN DOWN TO FINISHED FLOOR
- D-4 CONTRACTOR TO REMOVE BRICK VENEER FROM THE INDICATED EXISTING WALLS
- D-5 CONTRACTOR TO REMOVE INDICATED EXISTING WALLS DOWN TO FINISHED FLOOR. REMOVE EXISTING DOORS AND FRAMES AND TURN OVER TO OWNER.
- D-6 CONTRACTOR TO REMOVE EXISTING TOILET PARTITIONS
- D-7 CONTRACTOR TO REMOVE EXISTING WINDOWS IN RESTROOMS W/FRAME AND SILL, PATCH & REPAIR OPENINGS TO PREPARE FOR NEW WINDOWS INSTALLATION (SEE WINDOW SCHEDULE).
- D-8 CONTRACTOR TO REMOVE ALL FINISHED MATERIAL FROM INTERIOR WALLS BACK TO STUD.
- D-9 CONTRACTOR TO REMOVE EXISTING FLOOR TILE, & MORTAR BED.
- D-10 CONTRACTOR TO REMOVE 4X6 WOOD POSTS.
- D-11 CONTRACTOR TO REMOVE ALL TOILETS AND ONE URINAL, LOCATED NEXT TO A TOILET. ALL LAVATORIES & TWO OTHER URINALS ARE TO BE REMOVED, STORED & RE-INSTALLED AFTER RE-FINISHING IS COMPLETED.
- D-12 EXISTING WATER HEATER TO BE REMOVED.
- D-13 3" WATER SERVICE TO REMAIN. SEE PLUMBING PLANS FOR NEW WORK.
- D-14 EXISTING SITE LIGHTING TROUGH TO BE RELOCATED. SEE ELECTRICAL PLANS FOR NEW LOCATION.
- D-15 REMOVE EXISTING ELECTRICAL PANEL & METER BASE. REMOVE CONDUIT & SERVICE CONDUCTORS BACK TO TRANSFORMER. COORDINATE WORK WITH LOCAL POWER COMPANY.
- D-16 TELEPHONE PEDESTAL TO REMAIN. PROVIDE NEW 2" CONDUIT TO NEW MTP LOCATION.
- D-17 REMOVE EXISTING SPLIT SYSTEM HEAT PUMP SYSTEM IN ITS ENTIRETY.
- D-18 REMOVE EXISTING EAC AND TURN OVER TO OWNER FOR FUTURE USE.
- D-19 EXISTING FLOOR DRAIN TO REMAIN. MAINTAIN WASTE & VENT PIPING.
- D-20 EXISTING FLOOR DRAIN TO BE REMOVED. REMOVE DRAIN LINE BACK TO MAIN SO AS NOT TO CREATE A DEAD END.

LEGEND

--- EXISTING CONSTRUCTION TO BE DEMOLISHED (UON)

EXISTING FLOOR PLAN- DEMOLITION PLAN
SCALE: 1/4" = 1'-0"

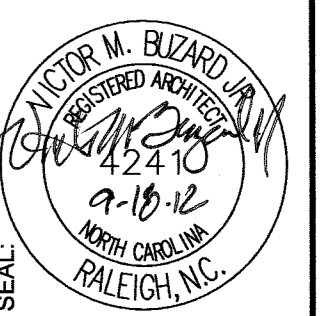

FACILITIES DESIGN
ARCHITECTS & ENGINEERS
FACILITIES MANAGEMENT DIVISION, NCDOT
1 SOUTH WILMINGTON STREET
919/715-0400 FAX: 919/715-0399
RALEIGH, NORTH CAROLINA 27601



Washington County US-64
Rest Area/ Visitor Center
1248 US-64 EAST,
PLYMOUTH, NC 27962

PROJECT:

TIP PROJ. NO.	K-5000
WBS NO.	41532.3.1
CONTRACT ID NO.	
FEDERAL ID NO.	NHS-0064(158)

REVISIONS	
NO.	DATE

DATE ISSUED: 10/9/12
DRAWN BY: AS
CHECKED BY: VB

SHEET NO.
A1
1 OF 12

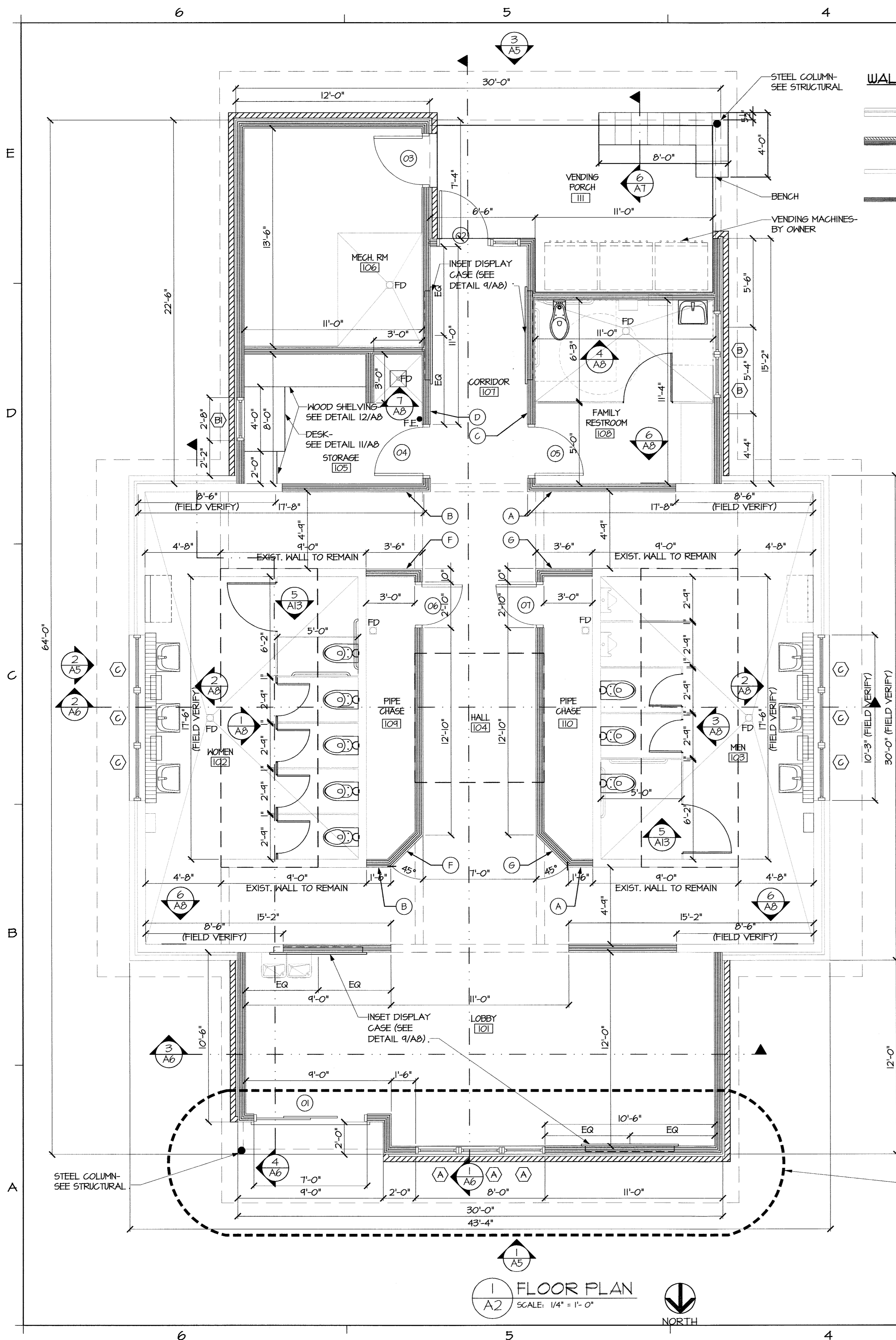

WALL LEGEND

- EXISTING EXTERIOR WALL- 6" WOOD STUDS @ 16" O.C., 1" AIRSPACE, BRICK VENEER
- NEW EXTERIOR WALL- 6" WOOD STUDS @ 16" O.C., 1-1/2" AIRSPACE, BRICK VENEER
- EXISTING INTERIOR WALL- 6" WOOD STUDS @ 16" O.C.
- NEW INTERIOR WALL- 6" WOOD STUDS @ 16" O.C.

GENERAL NOTES:

1. PROVIDE 5/8" GYPSUM BOARD @ ALL CEILINGS.
2. ALL FINISHED FLOOR ELEVATIONS F.F.E. ARE 100'-0" FOR BLDG. REF. ELEV. ONLY AND ALL FLOOR DRAINS SHALL BE SET AT 99'-10 1/2".
3. ALL INTERIOR & EXTERIOR WALLS ARE 2x6's @ 16" O.C. PROVIDE 5-1/2" SOUND BATTS IN ALL INTERIOR WALLS
4. INSIDE DIMENSIONS ARE TO THE FACE OF THE FRAMING.
5. PROVIDE MIN. 34" CLEAR OPENING TOILET PARTITION DOOR W/ PILASTERS @ INTERIOR OF FAMILY RESTROOM 108. PROVIDE SOLID WOOD BLOCKING FOR ALL TOILET PARTITIONS & ACCESSORIES.
6. SEE SHEET A-8 FOR BATHROOM ACCESSORY LOCATIONS & INFORMATION.
7. USE THIN-SET TILE INSTALLATION AT CONCRETE FLOORS & TILE BACKER PANELS AT WOOD STUD WALLS.
8. CAULK ALL INSIDE CORNERS AT TILE WALLS.
9. SEE SHEETS A9 THROUGH A11 FOR FINISH APPLICATION, SEE SPECIFICATION FOR EQUAL OR COMPETITIVE MANUFACTURERS OF FINISHES.
9. SIGNS PLACEMENT IS AS SHOWN ON FLOOR PLAN. SEE ROOM SIGNAGE ON SHEET A8 FOR SIGNS DESCRIPTION.

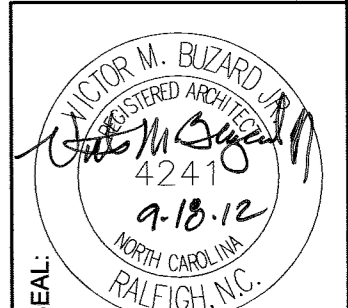
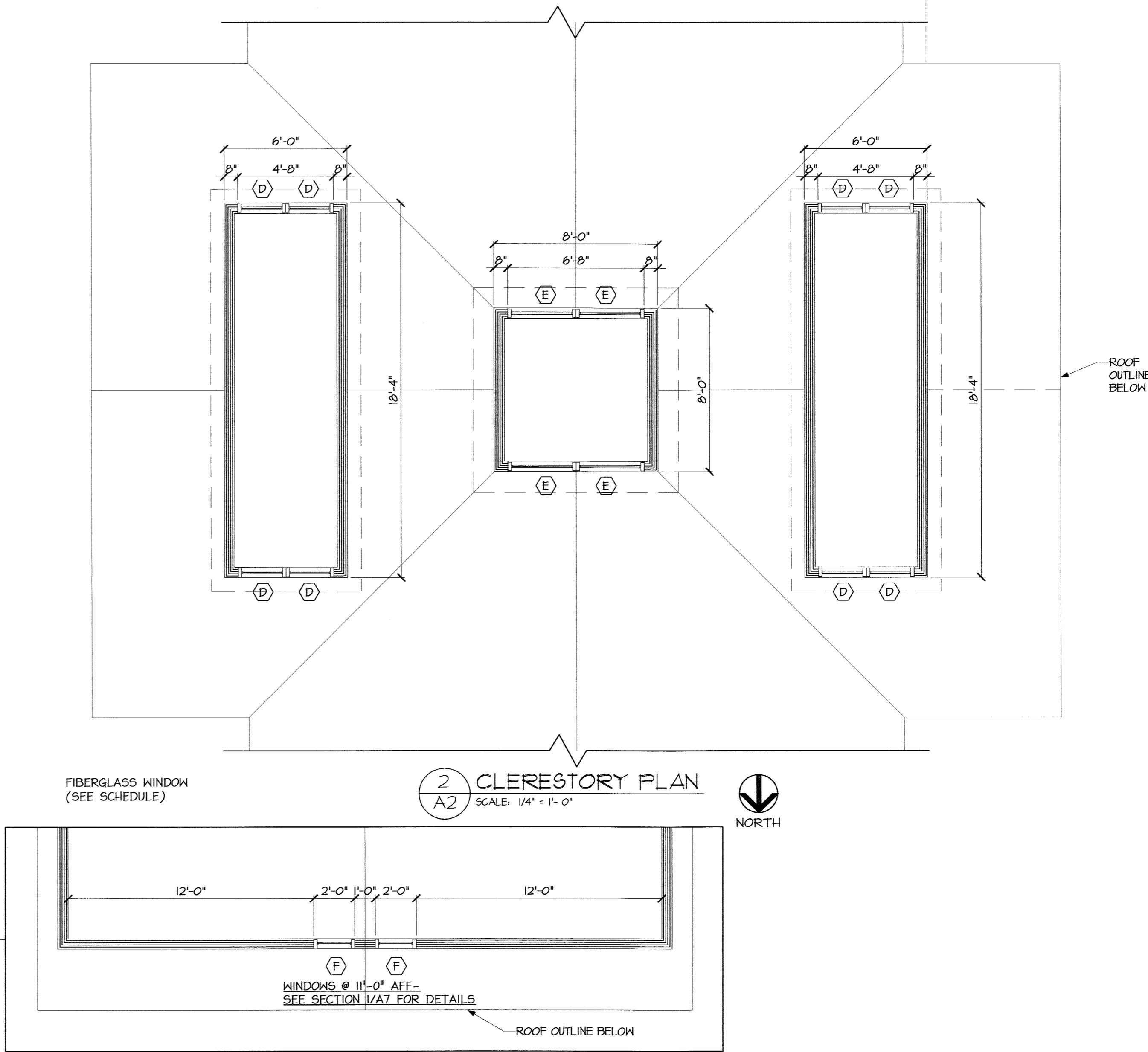

FACILITIES DESIGN
ARCHITECTS & ENGINEERS
FACILITIES MANAGEMENT DIVISION, NCDOT

1 SOUTH WILMINGTON STREET
919/775-0400 FAX: 919/775-0399
RALEIGH, NORTH CAROLINA 27601

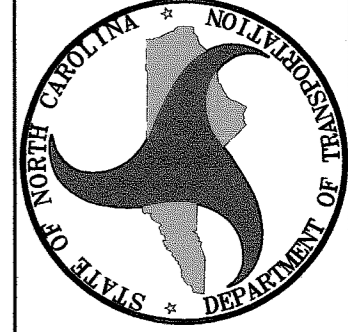

Washington County US-64
Rest Area/ Visitor Center
1248 US-64 EAST,
PLYMOUTH, NC 27962

PROJECT:

TIP PROJ. NO.	K-5000
WBS NO.	41532.31
CONTRACT ID NO.	
FEDERAL ID NO.	NHS-0064(158)
REVISIONS	DATE

DATE ISSUED: 10/9/12
DRAWN BY: AS
CHECKED BY: VB
SHEET NO.

A2

2 OF 12

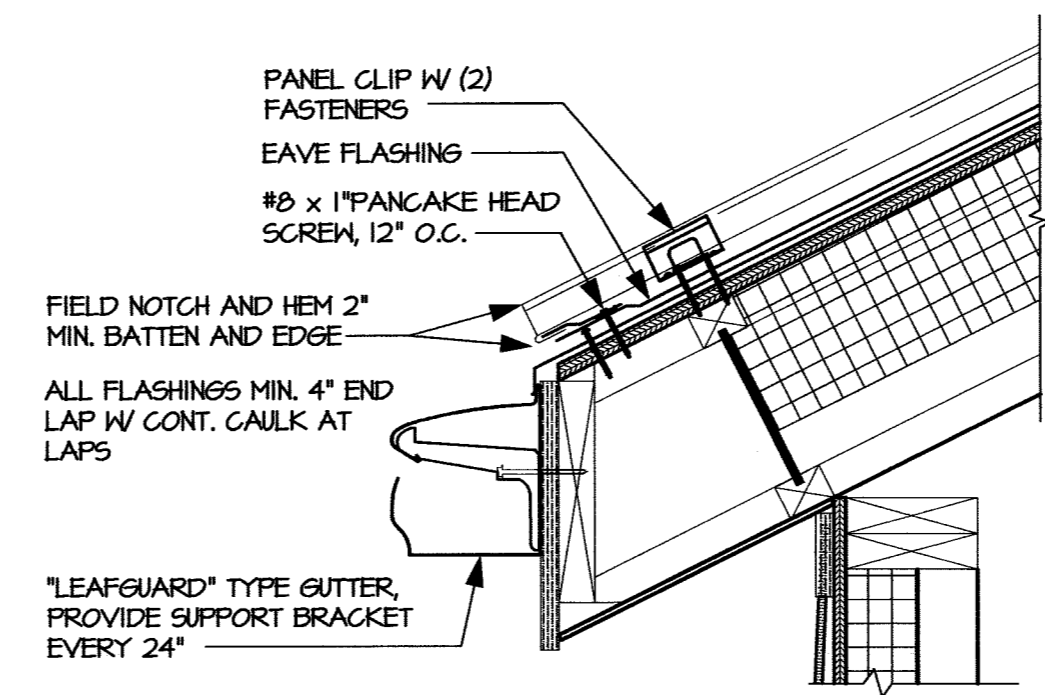
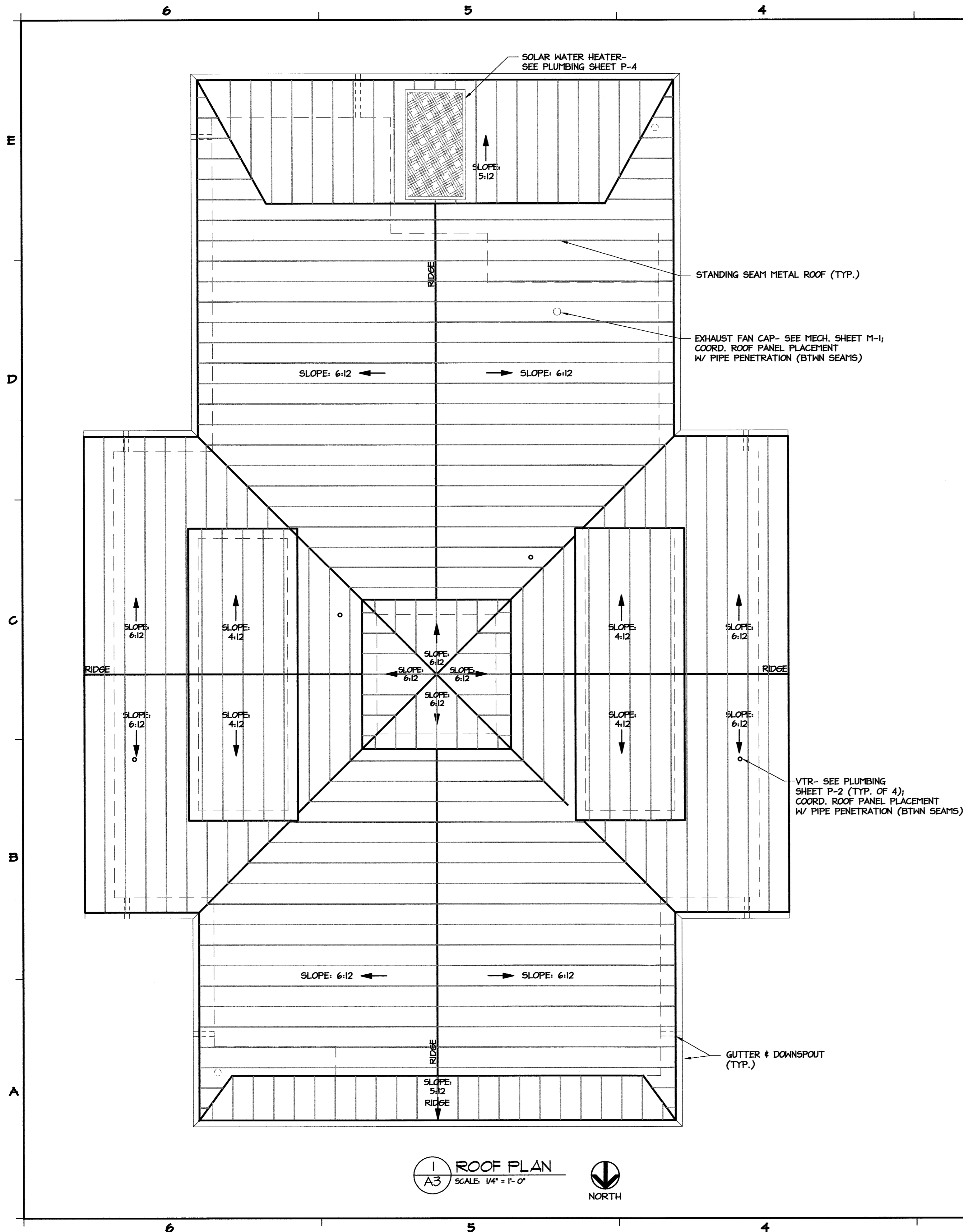

6 EAVE DETAIL
A3 NOT TO SCALE

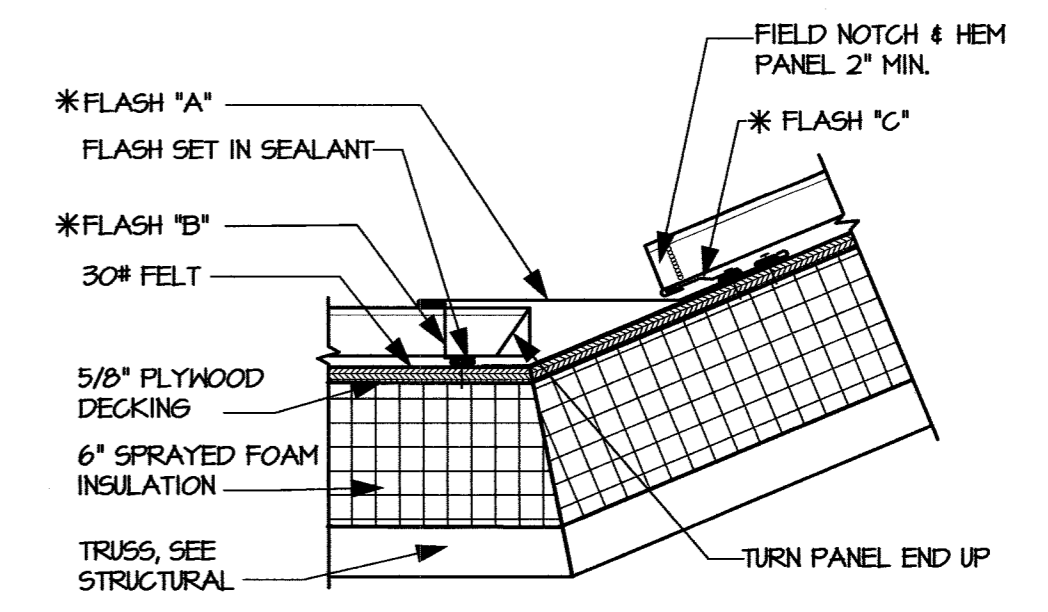

2 PITCH CHANGE DETAIL
A3 NOT TO SCALE

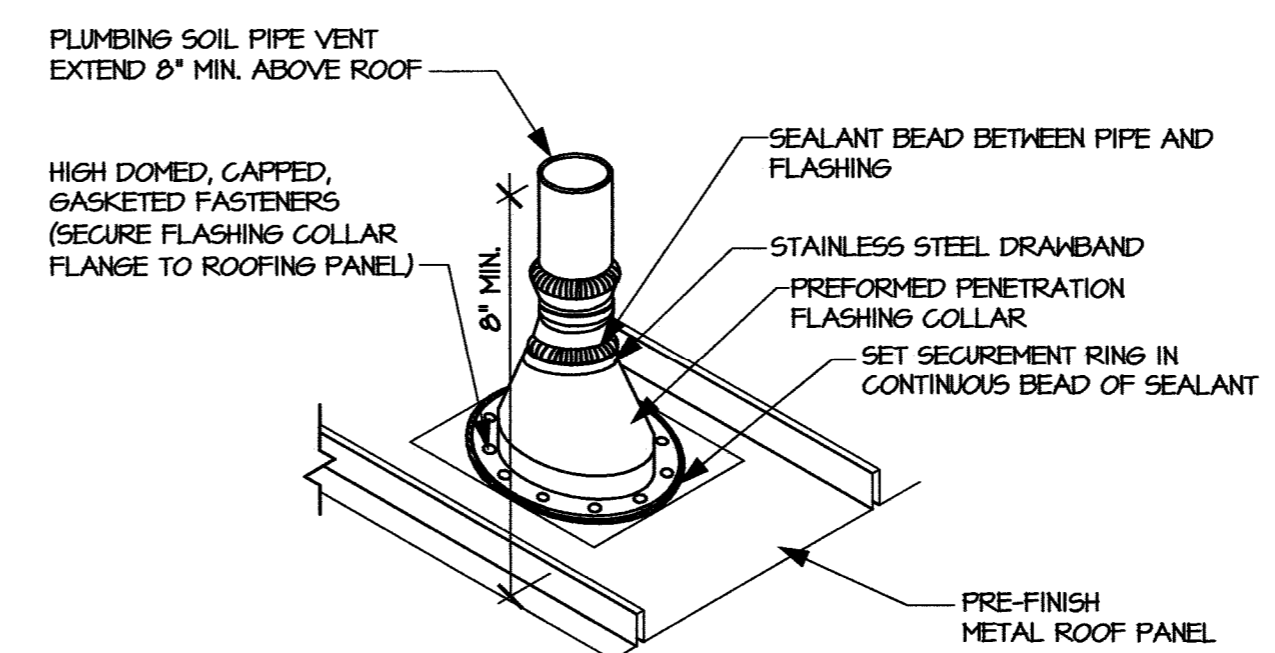

5 VTR DETAIL
A3 NOT TO SCALE

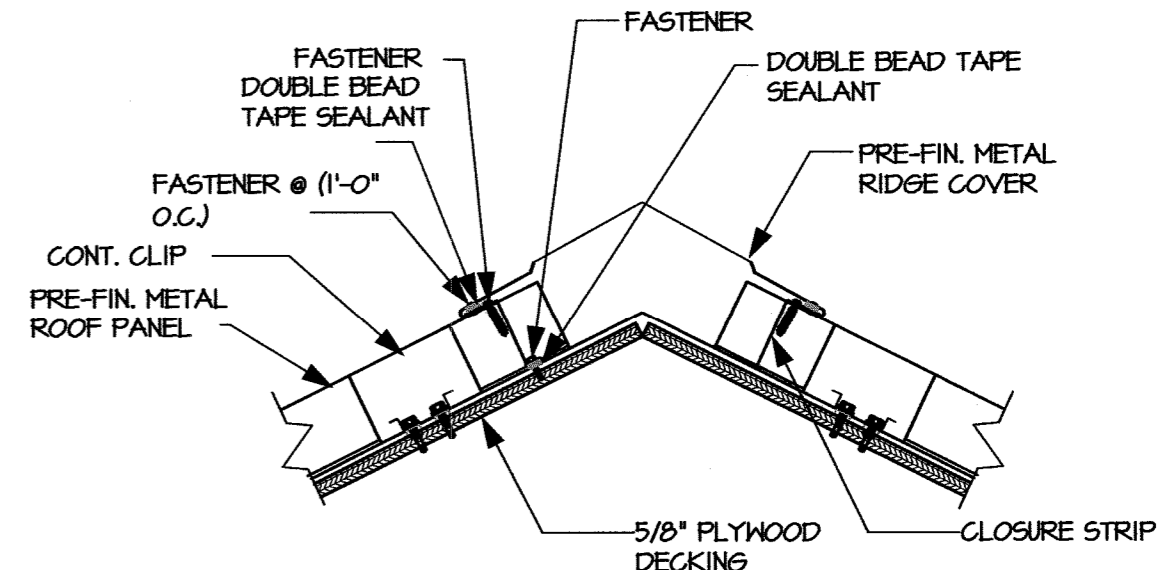

3 RIDGE DETAIL
A3 NOT TO SCALE

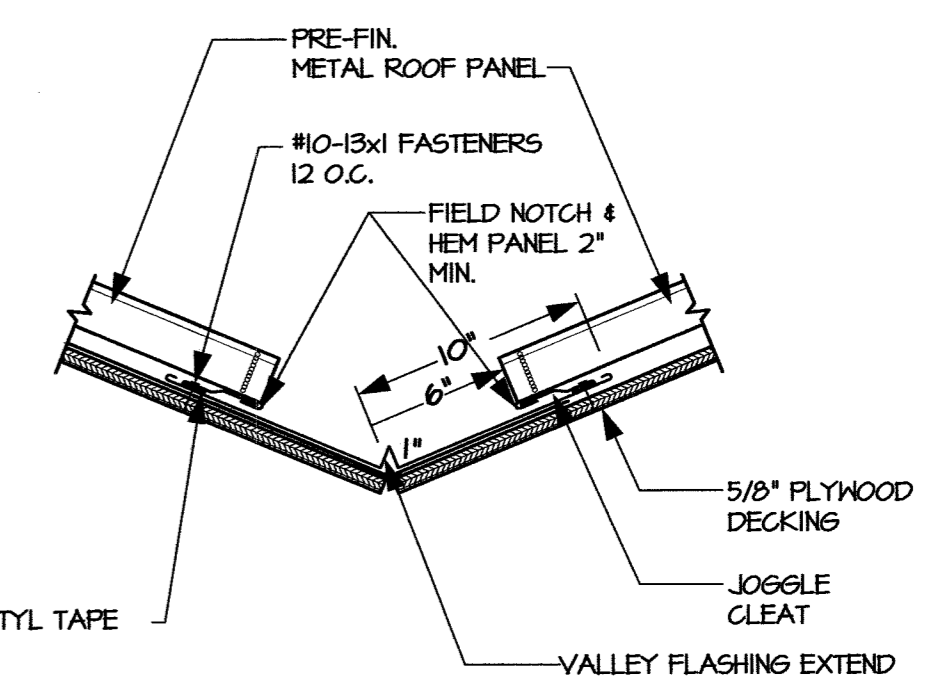

4 VALLEY DETAIL
A3 NOT TO SCALE

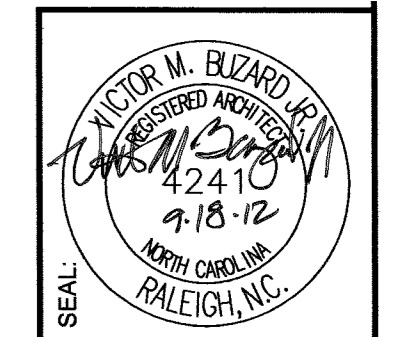

FACILITIES DESIGN
ARCHITECTS & ENGINEERS
FACILITIES MANAGEMENT DIVISION, NCDOT
1 SOUTH WILMINGTON STREET
RALEIGH, NORTH CAROLINA 27601
919/715-0400 FAX: 919/715-0399

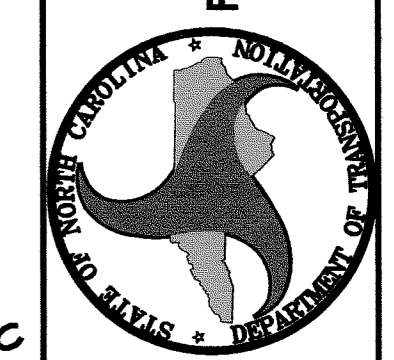

Washington County US-64
Rest Area/ Visitor Center
1248 US-64 EAST,
PLYMOUTH, NC 27962

PROJECT:

TIP PROJ. NO.	K-5000
WBS NO.	41532.3.1
CONTRACT ID NO.	
FEDERAL ID NO.	NHS-0064(158)
REVISIONS	
NO.	DATE
DATE ISSUED:	10/9/12
DRAWN BY:	AS
CHECKED BY:	VB
SHEET NO.	

A3

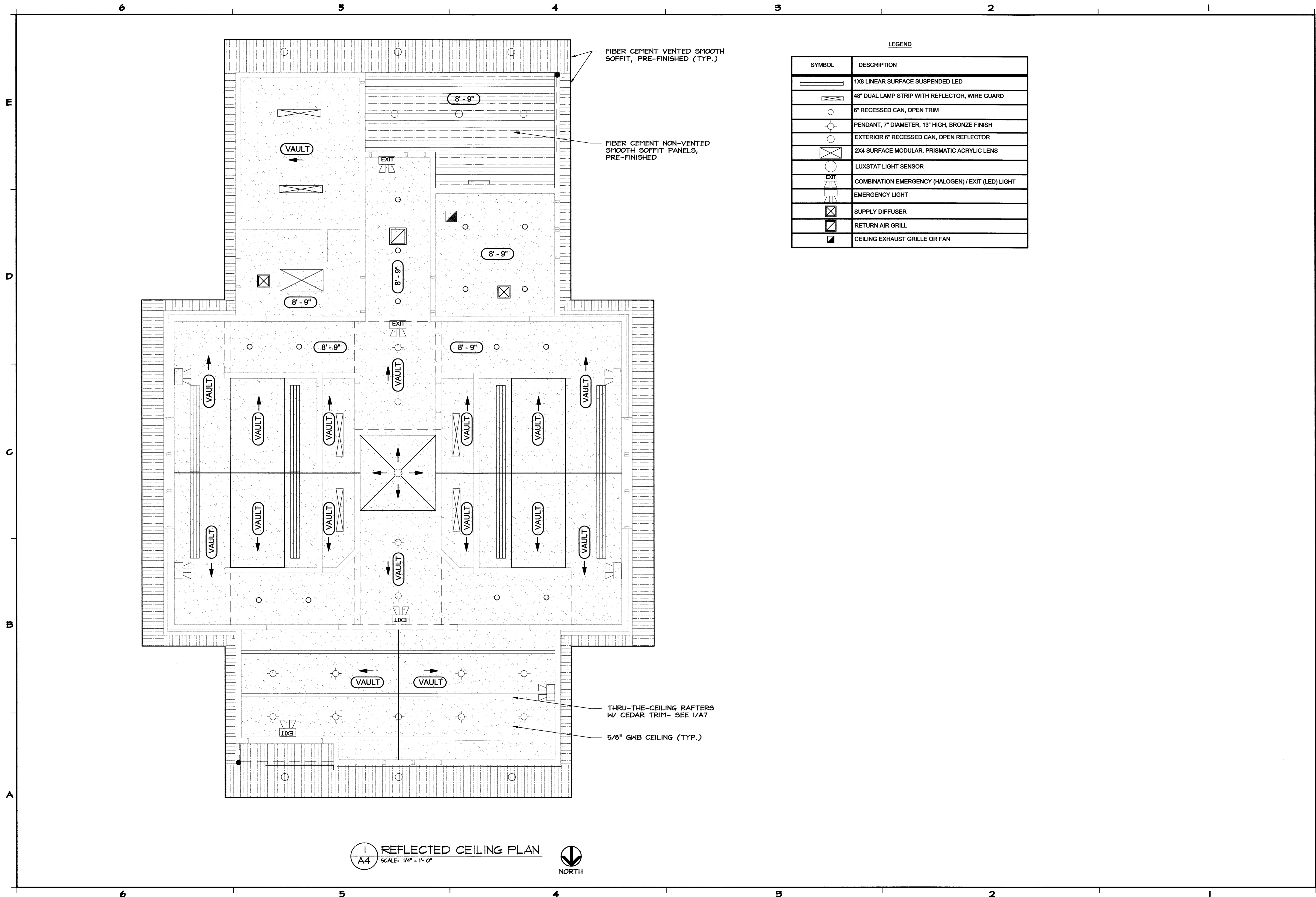

LEGEND

SYMBOL	DESCRIPTION
	1X8 LINEAR SURFACE SUSPENDED LED
	48\"/>
	6\"/>
	PENDANT, 7\"/>
	EXTERIOR 6\"/>
	2X4 SURFACE MODULAR, PRISMATIC ACRYLIC LENS
	LUXSTAT LIGHT SENSOR
	COMBINATION EMERGENCY (HALOGEN) / EXIT (LED) LIGHT
	EMERGENCY LIGHT
	SUPPLY DIFFUSER
	RETURN AIR GRILL
	CEILING EXHAUST GRILLE OR FAN

REFLECTED CEILING PLAN
 SCALE: 1/4" = 1'-0"
 NORTH

FACILITIES DESIGN
 ARCHITECTS & ENGINEERS
 FACILITIES MANAGEMENT DIVISION, NCDOT
 1 SOUTH WILMINGTON STREET
 RALEIGH, NORTH CAROLINA 27601
 919.715-0400 FAX: 919.715-0389

Washington County US-64
 Rest Area/ Visitor Center
 1248 US-64 EAST,
 PLYMOUTH, NC 27962

PROJECT:

TIP PROJ. NO.	K-5000
WBS NO.	41532.3.1
CONTRACT ID NO.	
FEDERAL ID NO.	NHS-0064(158)

REVISIONS

NO.	DATE

DATE ISSUED: 10/9/12
 DRAWN BY: AS
 CHECKED BY: VB

SHEET NO.
A4
 4 OF 12

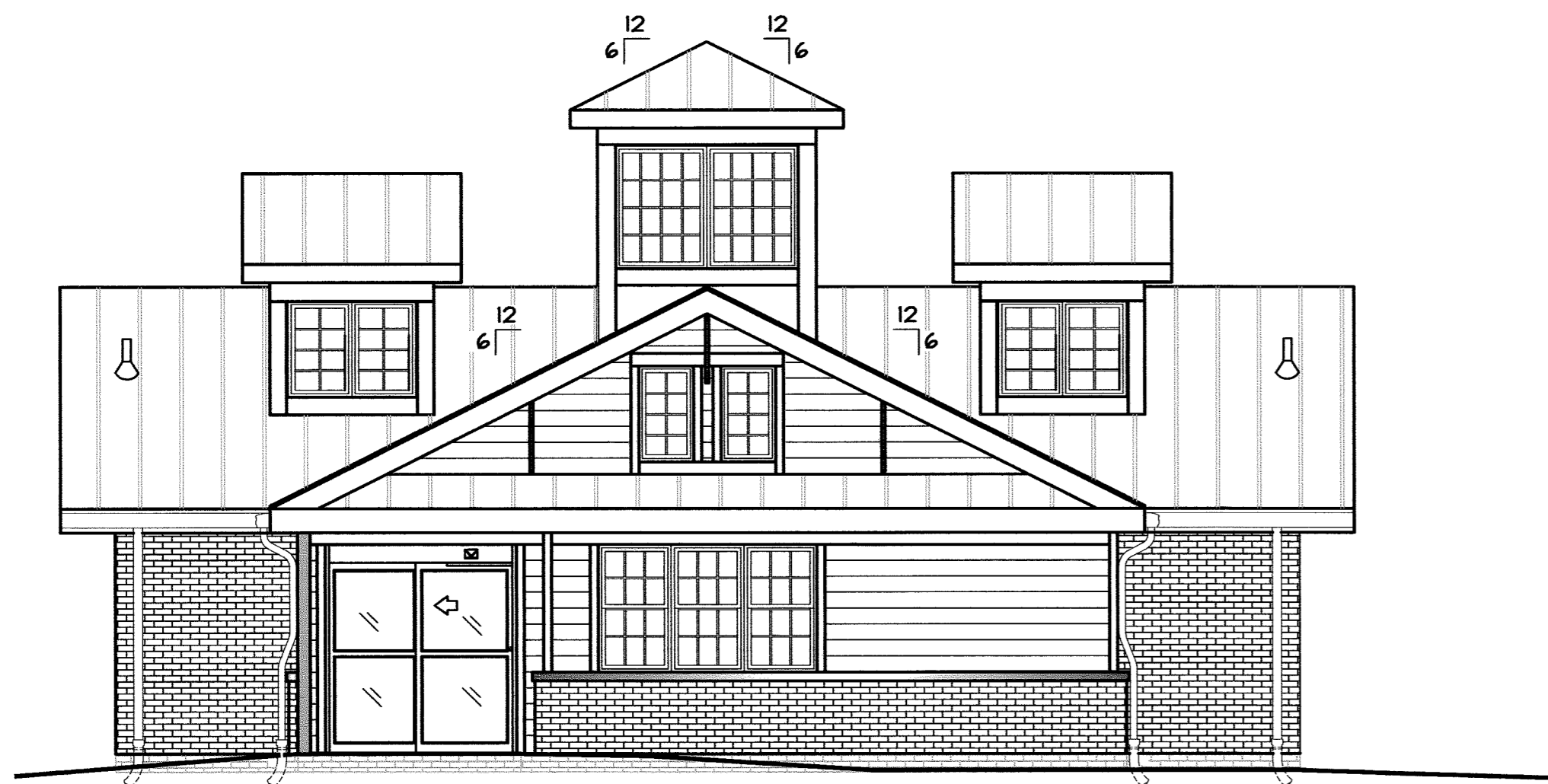

1 NORTH ELEVATION
A5 SCALE: 3/16" = 1'-0"

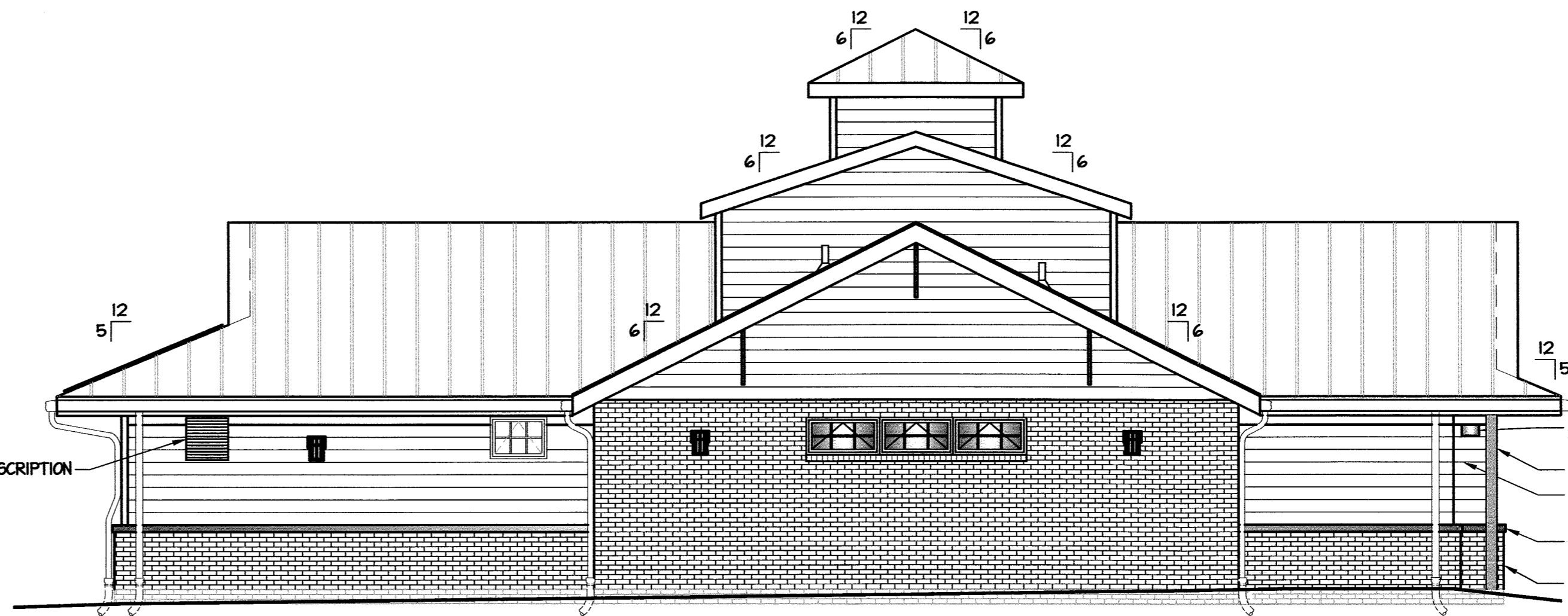

2 EAST ELEVATION
A5 SCALE: 3/16" = 1'-0"

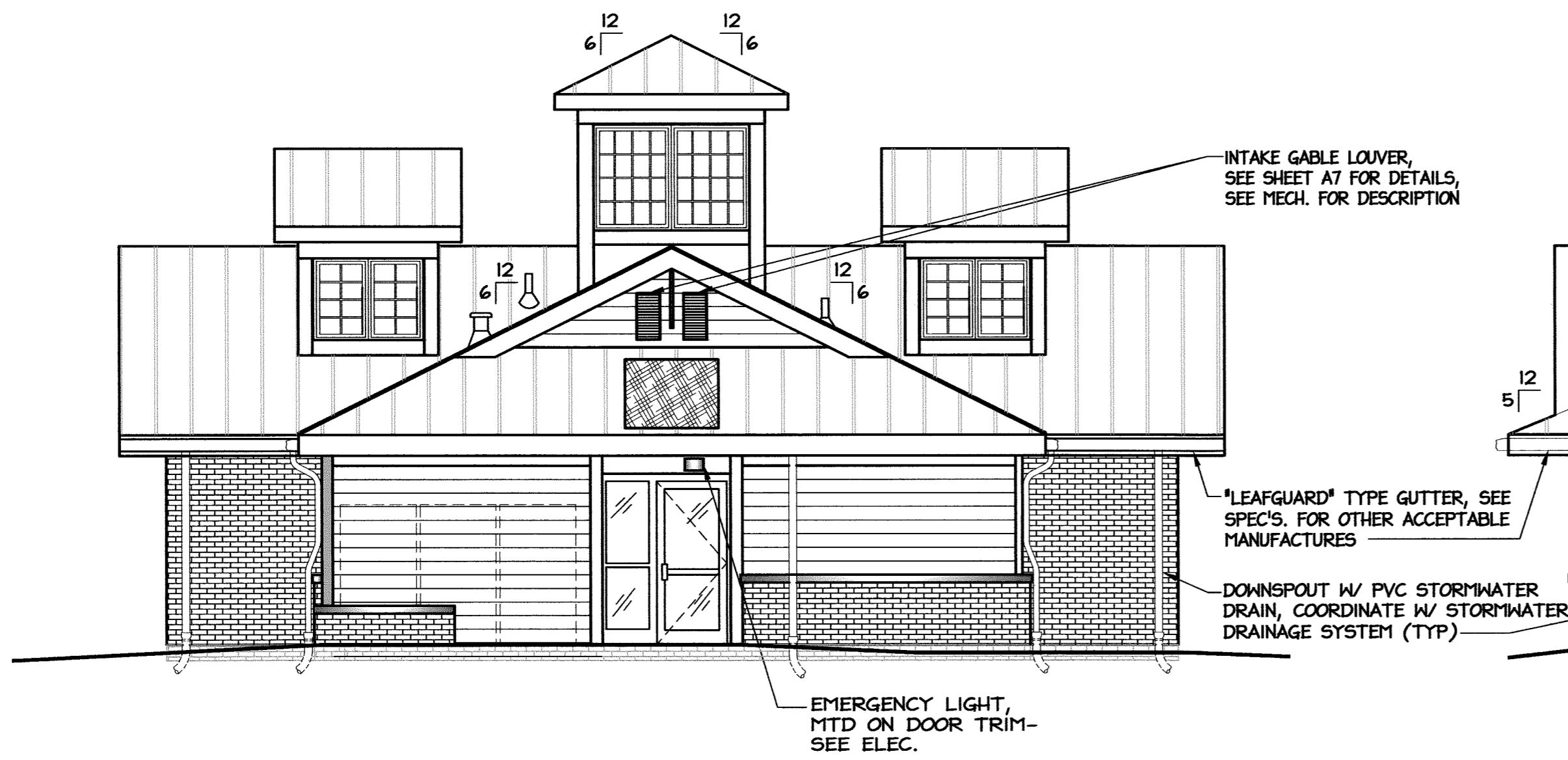

3 SOUTH ELEVATION
A5 SCALE: 3/16" = 1'-0"

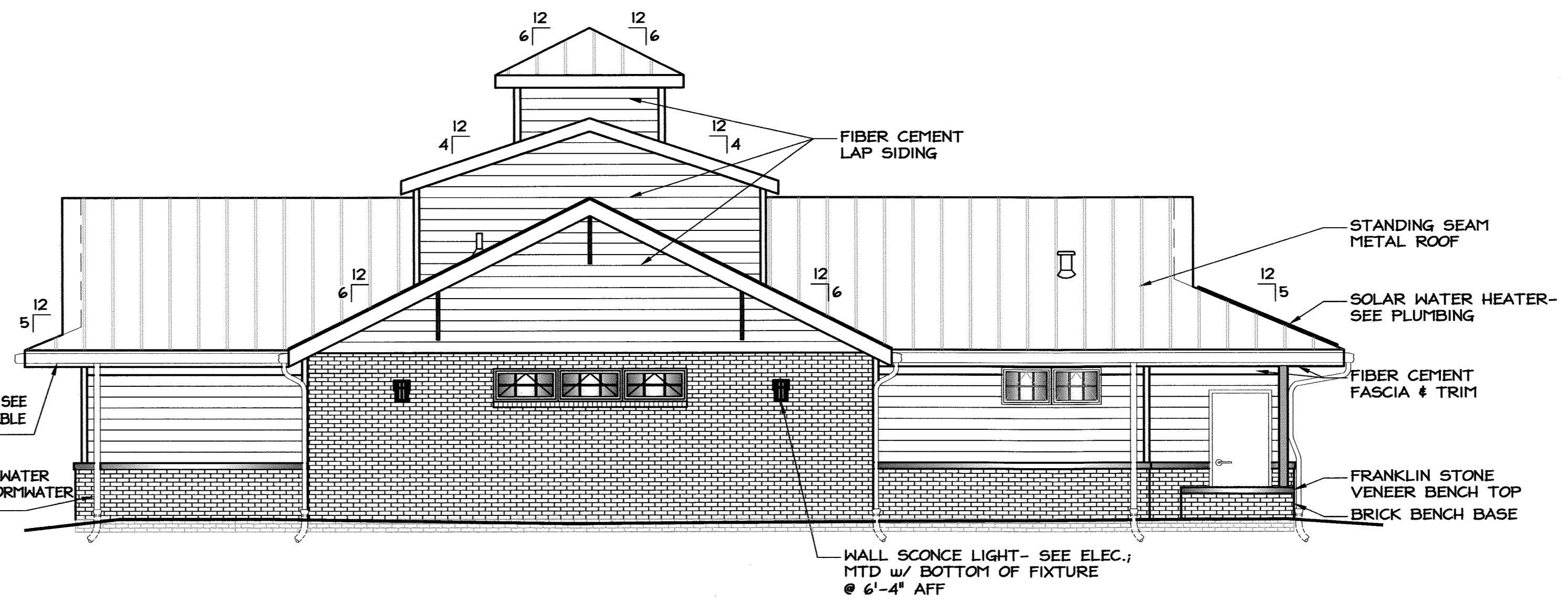

4 WEST ELEVATION
A5 SCALE: 3/16" = 1'-0"

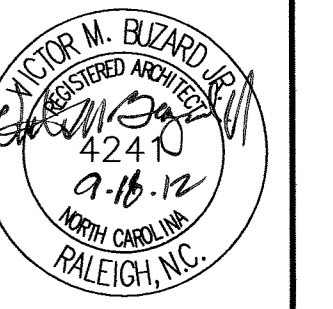

FACILITIES DESIGN
ARCHITECTS & ENGINEERS
FACILITIES MANAGEMENT DIVISION, NCDOT

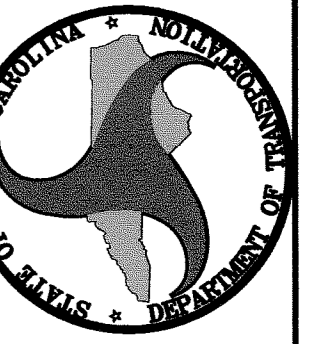

Washington County US-64
Rest Area/ Visitor Center
1248 US-64 EAST,
PLYMOUTH, NC 27962

PROJECT:

TIP PROJ. NO.	K-5000
WBS NO.	41532.3.1
CONTRACT ID NO.	
FEDERAL ID NO.	NHS-0064(158)
REVISIONS NO.	DATE

DATE ISSUED: 10/9/12
DRAWN BY: AS
CHECKED BY: VB
SHEET NO.

A5

5 OF 12

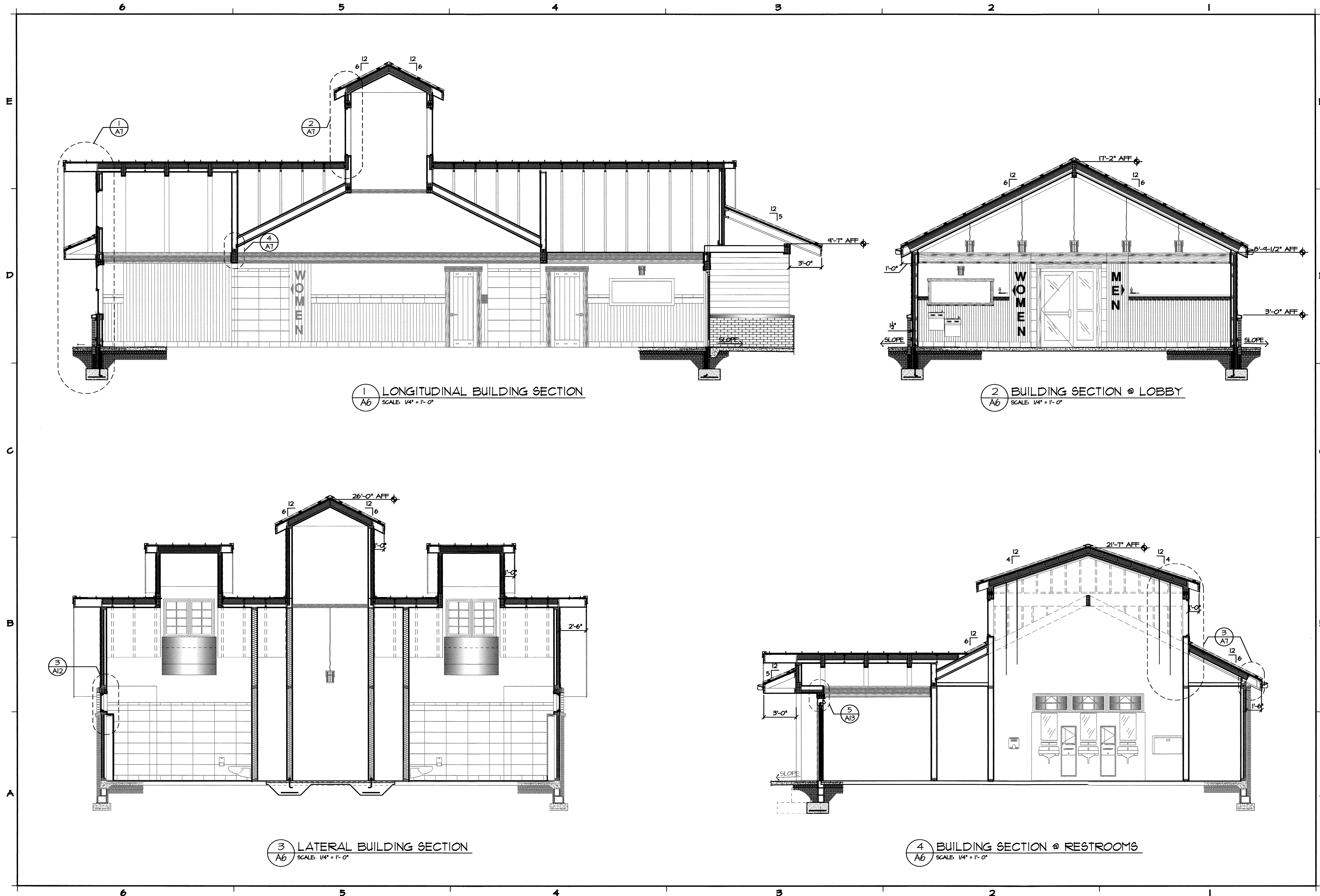

1 LONGITUDINAL BUILDING SECTION
A6 SCALE: 1/4" = 1'-0"

2 BUILDING SECTION @ LOBBY
A6 SCALE: 1/4" = 1'-0"

3 LATERAL BUILDING SECTION
A6 SCALE: 1/4" = 1'-0"

4 BUILDING SECTION @ RESTROOMS
A6 SCALE: 1/4" = 1'-0"

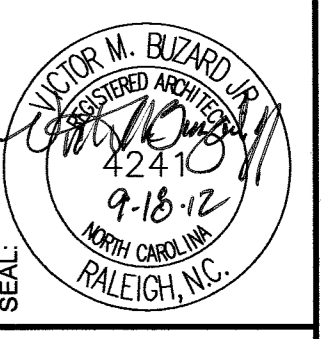

FACILITIES DESIGN
ARCHITECTS & ENGINEERS
 FACILITIES MANAGEMENT DIVISION, NCDOT
 1 SOUTH WILMINGTON STREET
 RALEIGH, NORTH CAROLINA 27601
 919.715-0400 FAX 919.715-6399

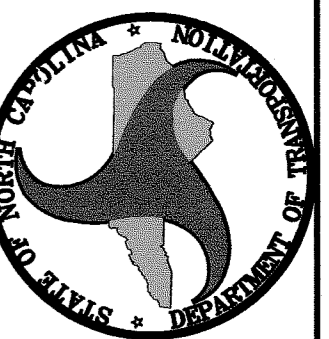

PROJECT:
 Washington County US-64
 Rest Area/ Visitor Center
 1248 US-64 EAST,
 PLYMOUTH, NC 27962

TIP PROJ. NO.	K-5000
WBS NO.	41532.3.1
CONTRACT ID NO.	
FEDERAL ID NO.	NHS-0064(158)
REVISIONS NO.	DATE

DATE ISSUED: 10/9/12
 DRAWN BY: AS
 CHECKED BY: VB

SHEET NO.
A6
 6 OF 12

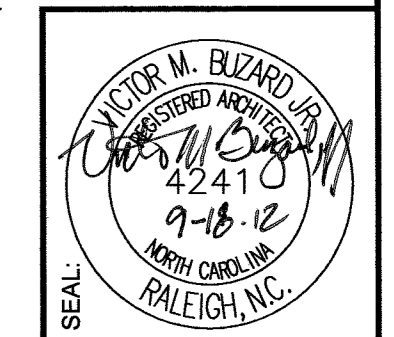
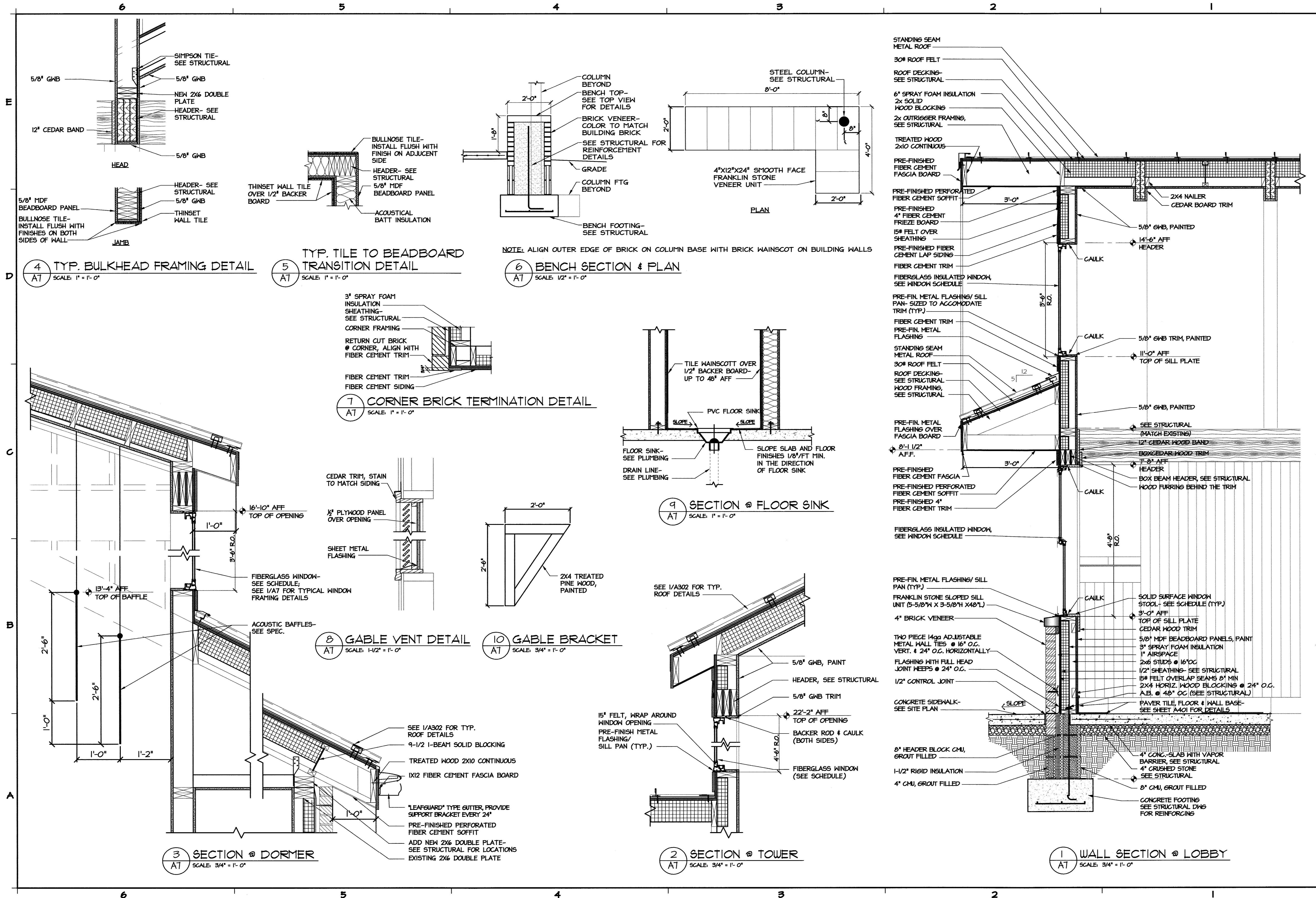

FACILITIES DESIGN
ARCHITECTS & ENGINEERS
 FACILITIES MANAGEMENT DIVISION, NCDOT
 1 SOUTH WILMINGTON STREET
 RALEIGH, NORTH CAROLINA 27601
 919.715-0400 FAX: 919.715-0399

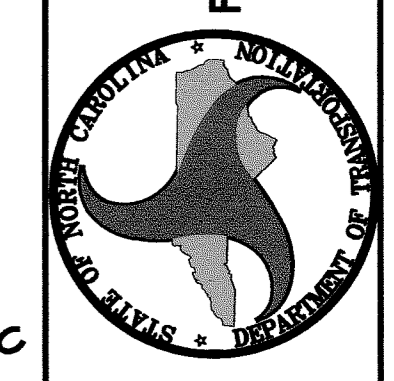

Washington County US-64
 Rest Area/ Visitor Center
 1248 US-64 EAST,
 PLYMOUTH, NC 27962

PROJECT:

TIP PROJ. NO.	K-5000
WBS NO.	41532.3.1
CONTRACT ID NO.	
FEDERAL ID NO.	NHS-0064(158)
REVISIONS NO.	DATE

DATE ISSUED: 10/9/12
 DRAWN BY: AS
 CHECKED BY: VB
 SHEET NO.

A7
 7 OF 12

NOTES:
 1. SEE INTERIOR ELEVATIONS SHEETS A1-A12 FOR WALL FINISHES.
 2. EXISTING LAVATORIES SHOULD BE RE-INSTALLED TO THEIR ORIGINAL LOCATIONS

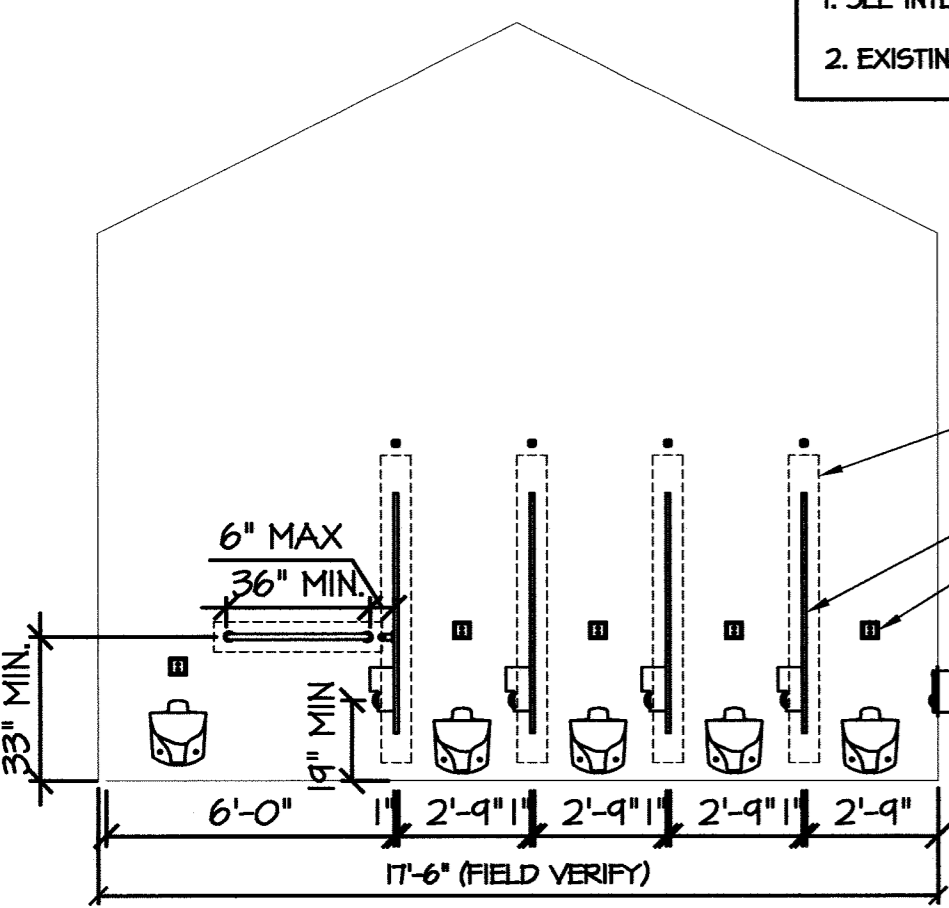

1 ELEVATION: RM 102
 A-B SCALE: 1/4" = 1'-0"

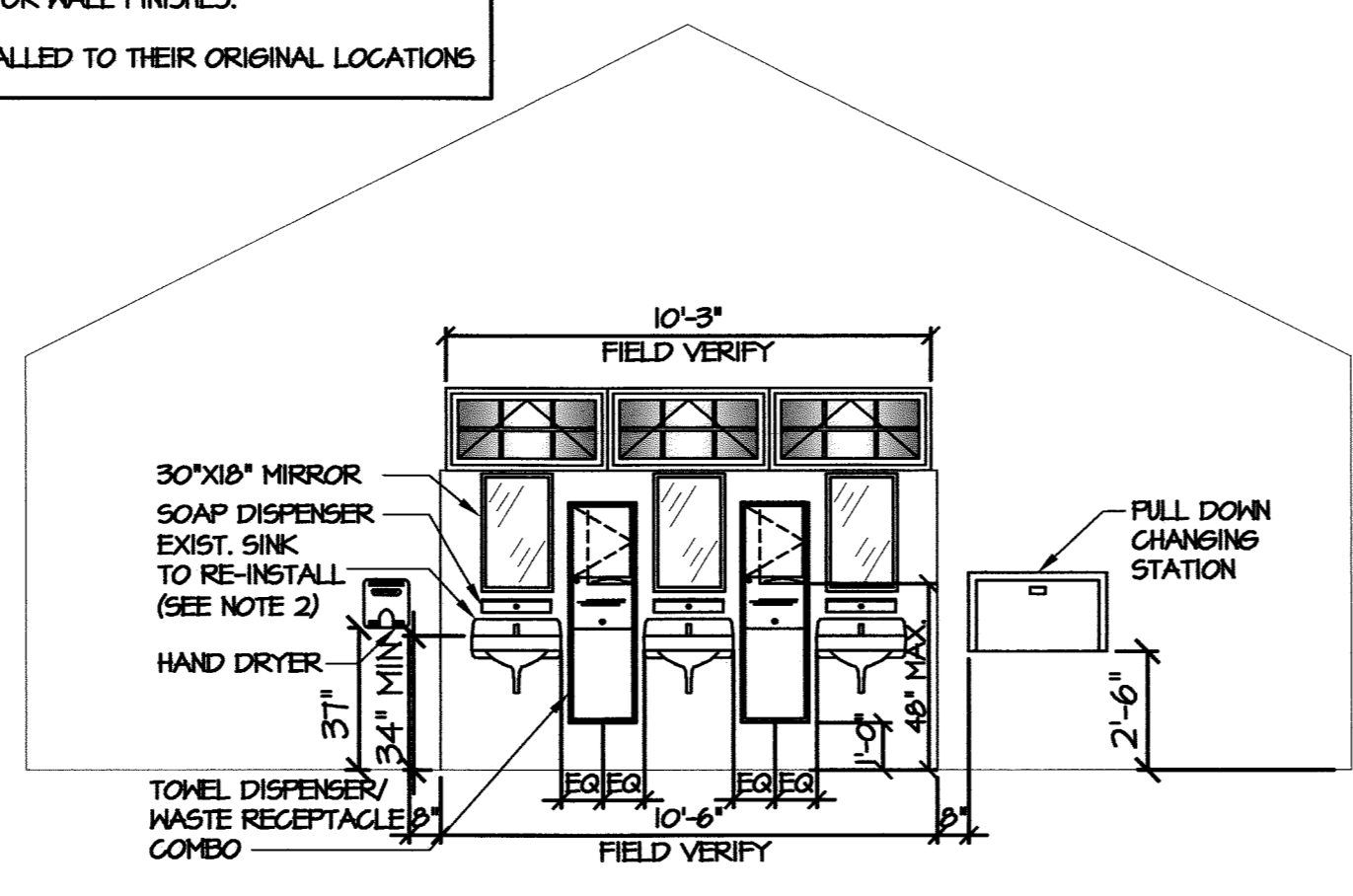

2 ELEVATION: RM 102 & 103
 A-B SCALE: 1/4" = 1'-0"

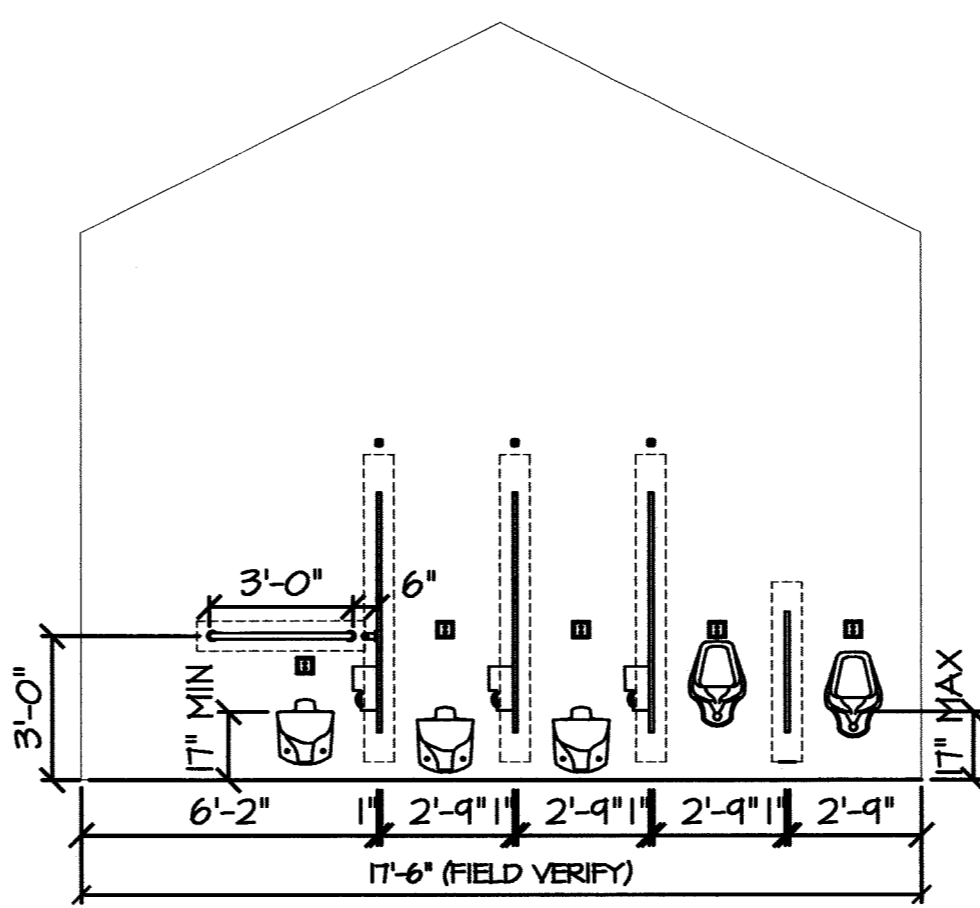

3 ELEVATION: RM 103
 A-B SCALE: 1/4" = 1'-0"

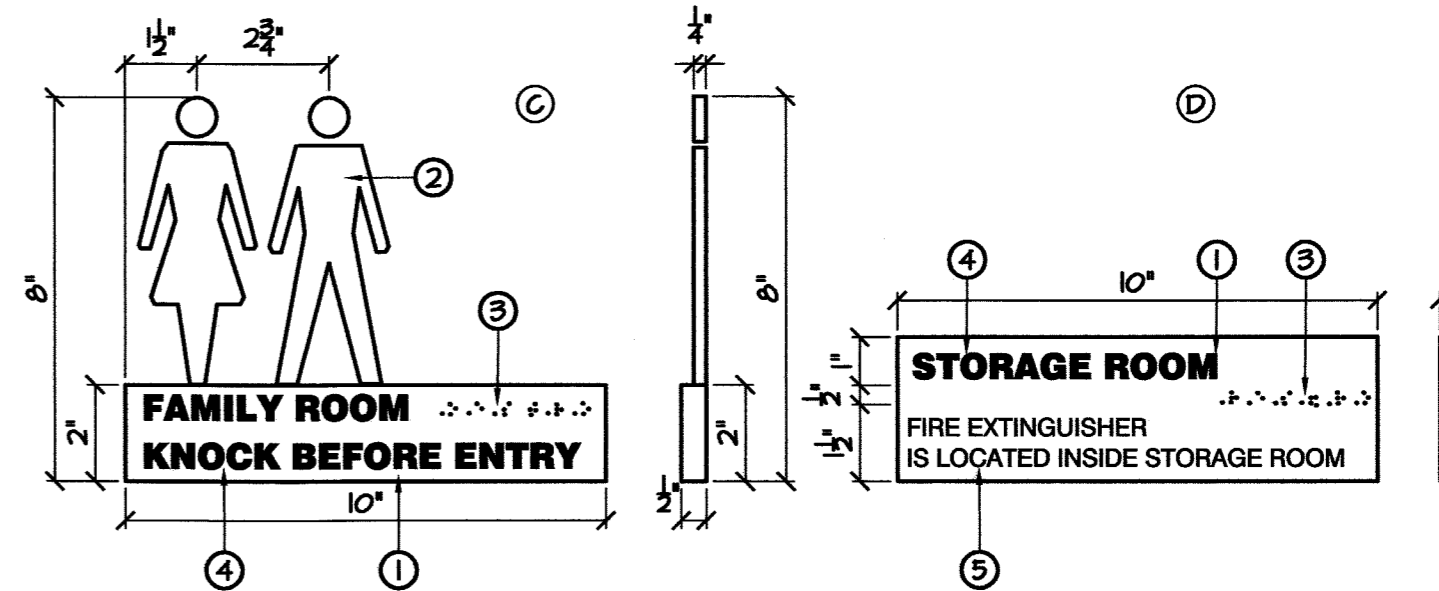
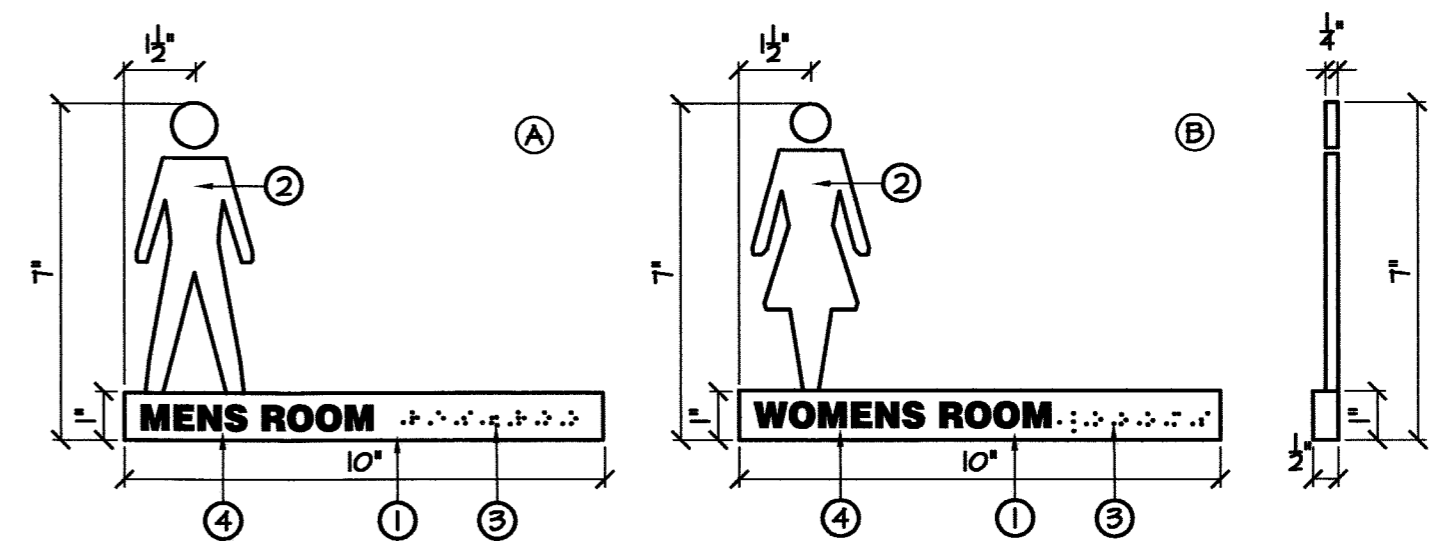

ROOM SIGNAGE SCHEDULE

ROOM NO.	ROOM NAME	SIGNAGE TYPE	QTY
103	MEN	A	2
104	WOMEN	B	2
105	FAMILY RESTROOM	C	1
105	STORAGE	D	1
103	MEN	E	2
104	WOMEN	F	2

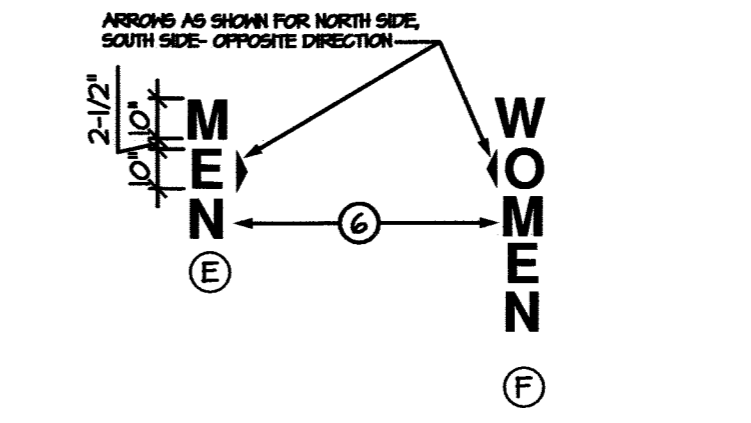

SIGNAGE NOTES:
 1. REFER TO DOOR SCHEDULE FOR ROOM NUMBER, ROOM NAME, AND SIGNAGE LOCATION U.O.N.
 2. SIGNAGE SHALL COMPLY WITH ANSI A117.1-2008.
 3. SIGNS A THRU D SHALL BE MOUNTED WITH CENTERLINE OF PLAQUE AT 60" AFF.
 4. SEE FLOOR PLAN SHEET A2 FOR SIGNS LOCATIONS.
 5. SEE PROJECT SPECIFICATIONS FOR ADDITIONAL INFORMATION.

KEY NOTES:
 1. 1/2" THICK MILLED POLISHED ALUMINUM PLAQUE.
 2. 1/4" THICK MILLED BRUSHED ALUMINUM PLAQUE.
 3. RAISED METAL BEAD BRAILE.
 4. BLUE SILKSCREENED LETTERING- HELVETICA BOLD FONT, 5/8" TEXT HEIGHT.
 5. BLUE SILKSCREENED LETTERING- HELVETICA BOLD FONT, 3/8" TEXT HEIGHT.
 6. INDIVIDUAL METAL LETTERS: 1/2" THICK MILLED BRUSHED ALUMINUM PLATE, BLUE SILKSCREENED LETTERING- HELVETICA BOLD FONT, 10" TEXT HEIGHT.

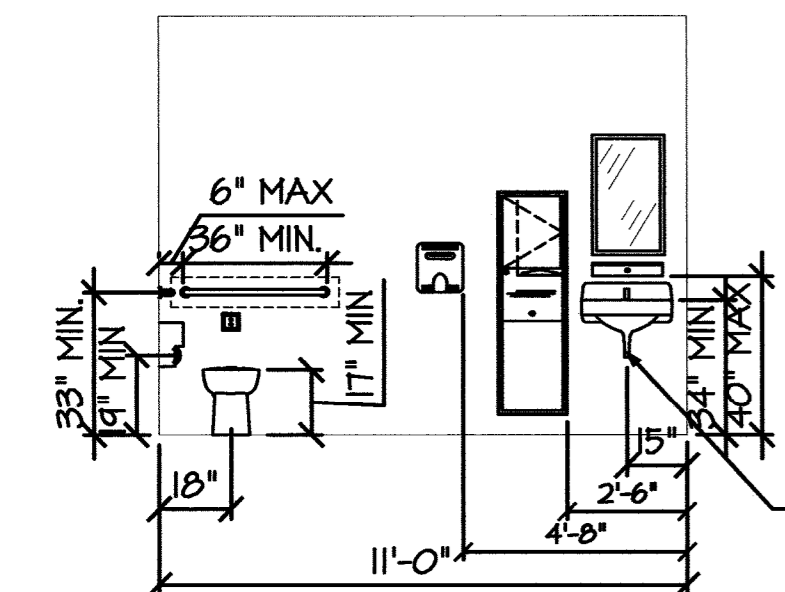

4 ELEVATION: RM 108
 A-B SCALE: 1/4" = 1'-0"

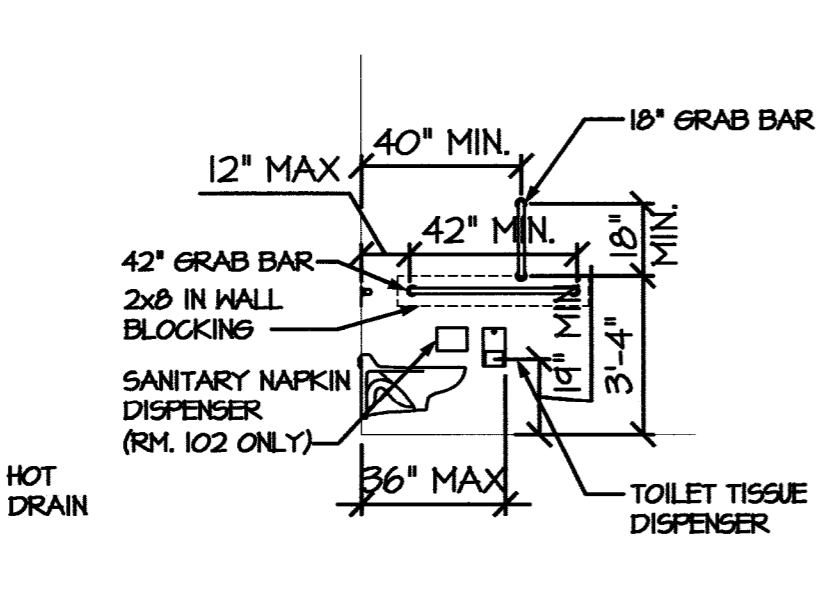

5 ELEVATION: HC STALL - TYP.
 A-B SCALE: 1/4" = 1'-0"

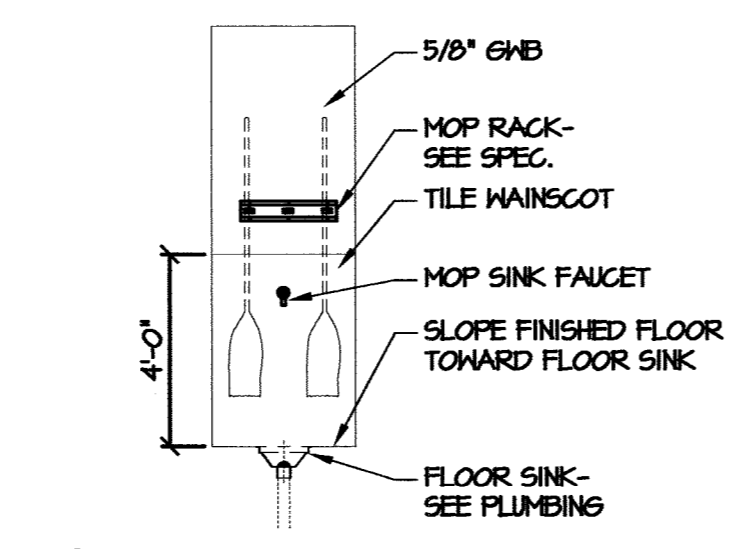

7 ELEVATION @ FLOOR SINK
 A-B SCALE: 1/4" = 1'-0"

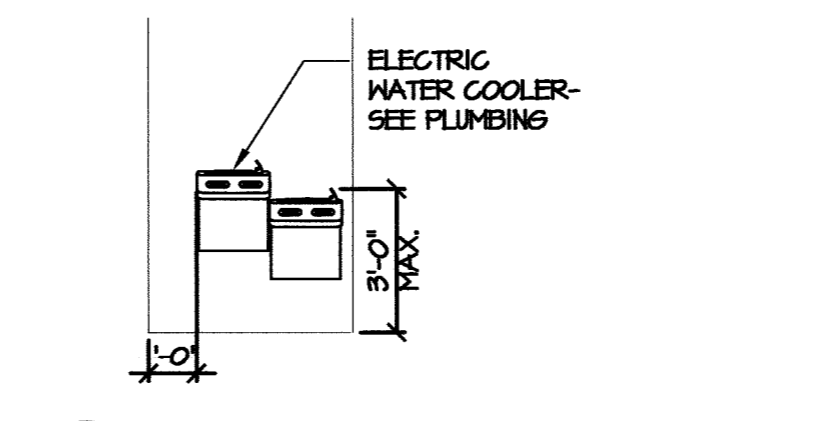

8 EWC ELEVATION: RM 101
 A-B SCALE: 1/4" = 1'-0"

TOILET ACCESSORIES SCHEDULE*

ROOM NO.	ROOM NAME	TOILET PAPER DISPENSER	SANITARY NAPKIN DISPOSAL	TOWEL DISP. WASTE REC.	MIRROR 18x30	MIRROR 24x60	SOAP DISP.	BABY CHANGING STATION	ELEC. HAND DRYER	36" GRAB BAR	42" GRAB BAR	MOP RACK
102	WOMEN	5	5	2	3	1	3	1	1	1	1	-
103	MEN	3	-	2	3	1	3	1	1	1	1	-
105	STORAGE	-	-	-	-	-	-	-	-	-	-	-
105	FAMILY RESTROOM	-	-	-	-	-	-	-	-	-	-	-

* SEE SPEC SECTION 10B10 FOR MANUFACTURERS AND PRODUCTS DESCRIPTION.

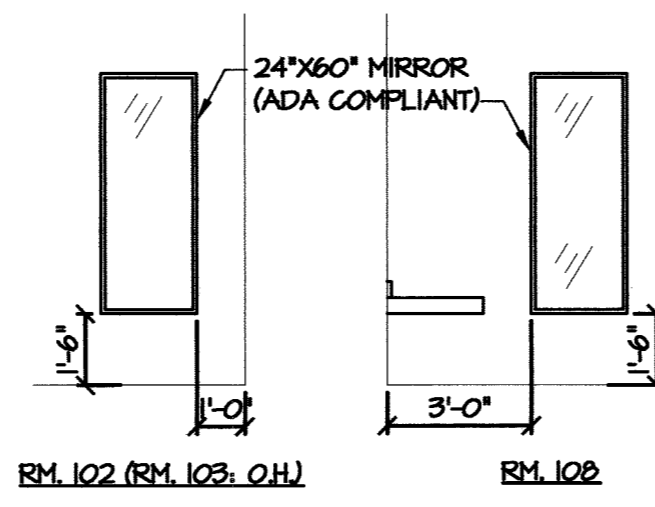

6 ELEVATION: FULL LENGTH MIRROR
 A-B SCALE: 1/4" = 1'-0"

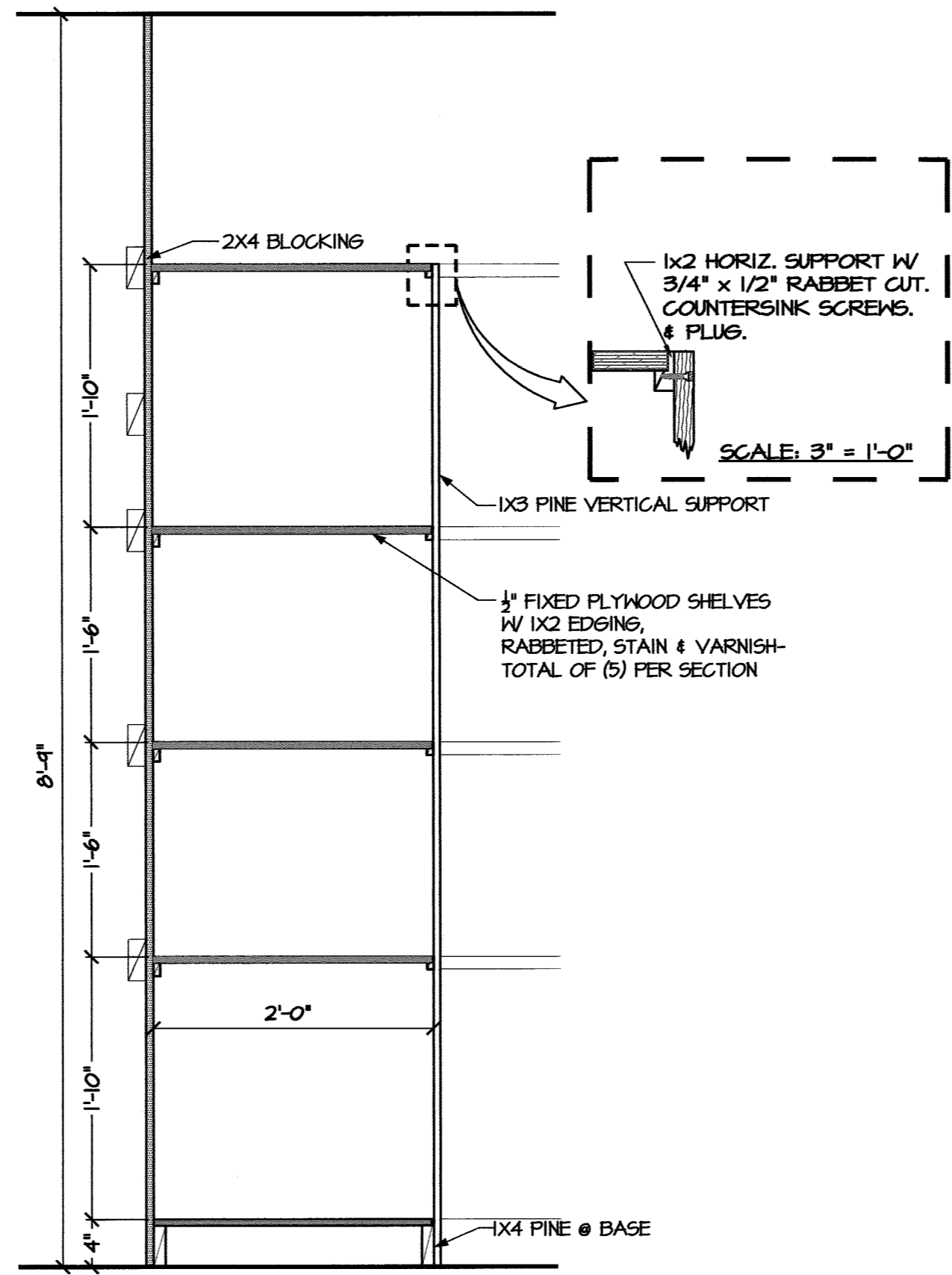

12 SECTION- SHELVING @ STORAGE
 A-B SCALE: 1" = 1'-0"

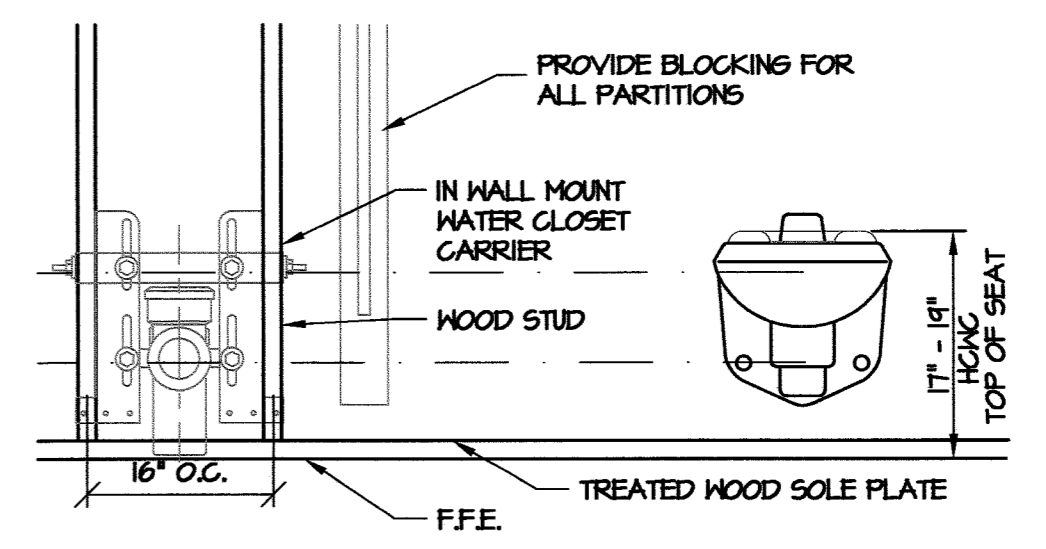

13 WATER CLOSET CARRIER DETAIL
 A-B SCALE: 3/4" = 1'-0"

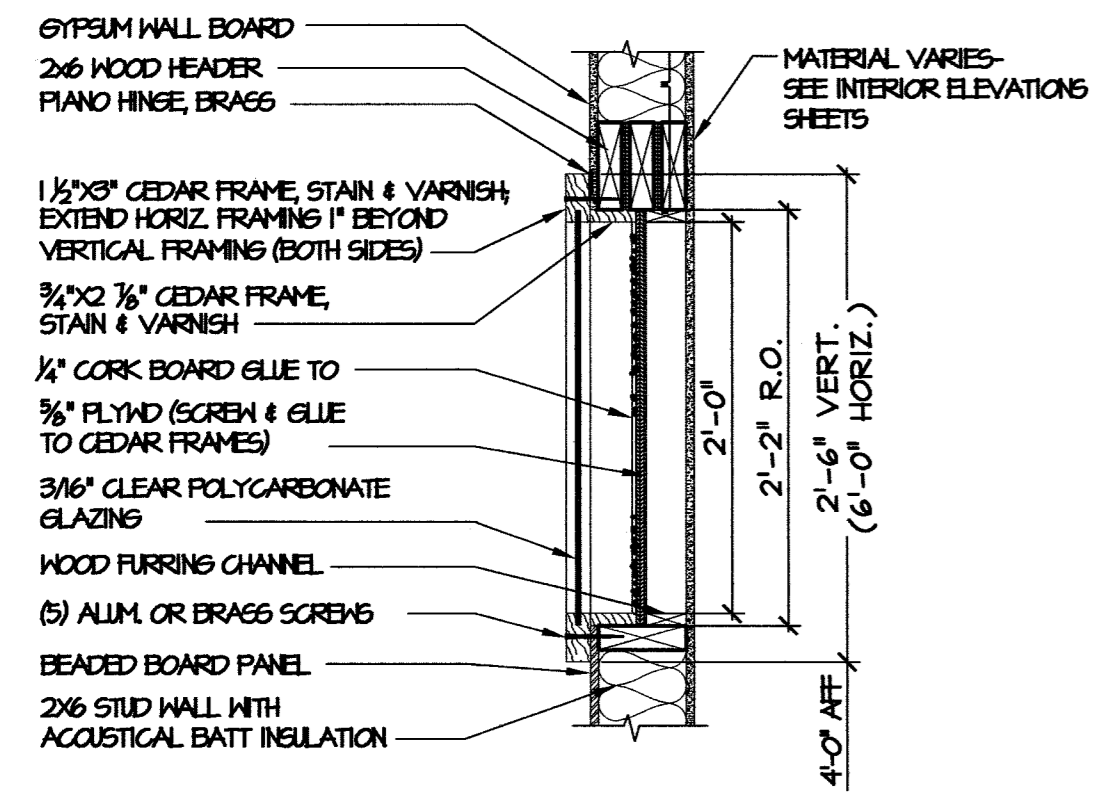

9 SECTION- DISPLAY CASE
 A-B SCALE: 1" = 1'-0"

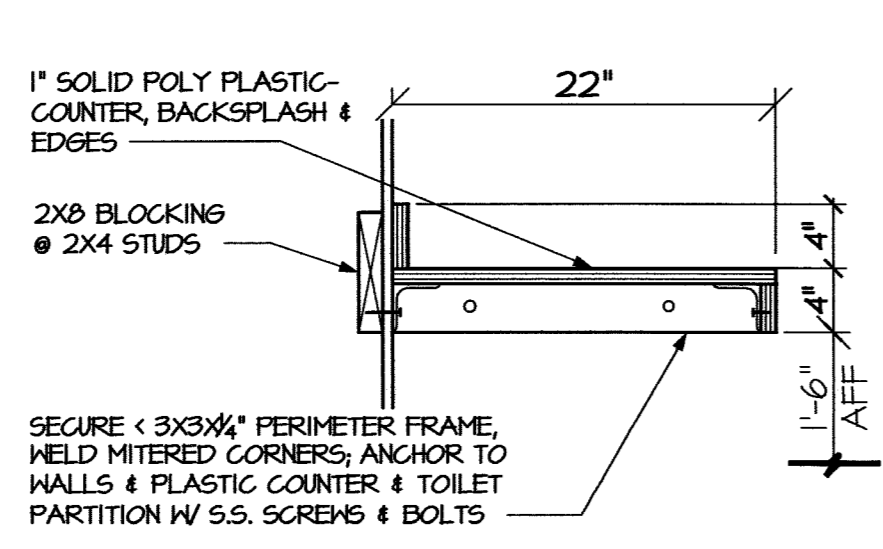

10 SECTION- BENCH @ FAMILY RM.
 A-B SCALE: 1" = 1'-0"

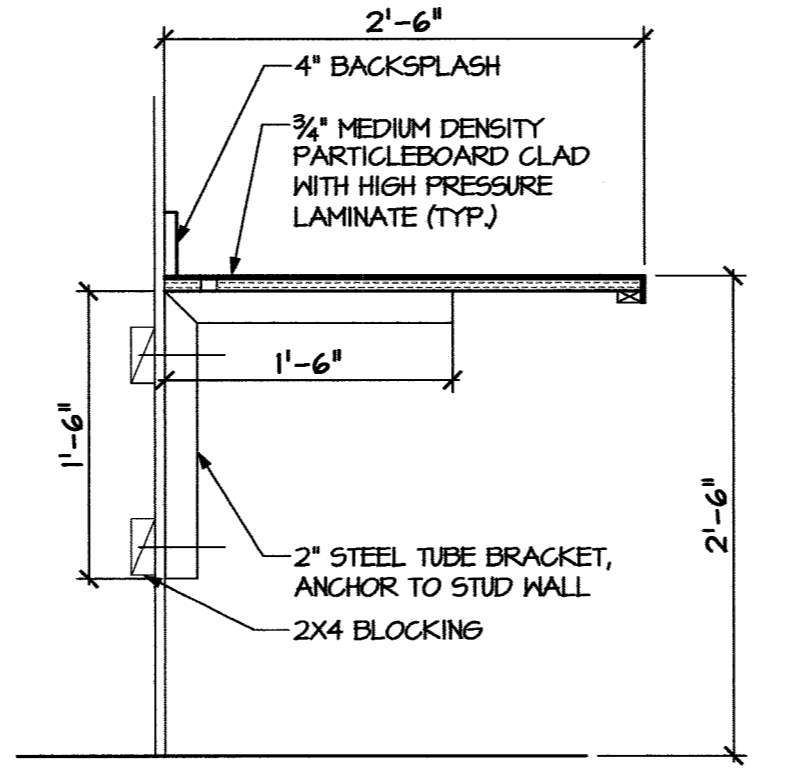

11 SECTION- DESK @ STORAGE
 A-B SCALE: 1" = 1'-0"

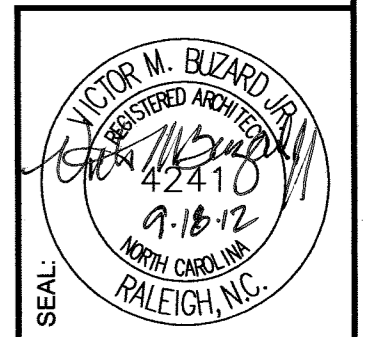

FACILITIES DESIGN
 ARCHITECTS & ENGINEERS
 FACILITIES MANAGEMENT DIVISION, NCDOT
 1 SOUTH WILMINGTON STREET
 RALEIGH, NORTH CAROLINA 27601
 919/775-0400 FAX: 919/775-0399

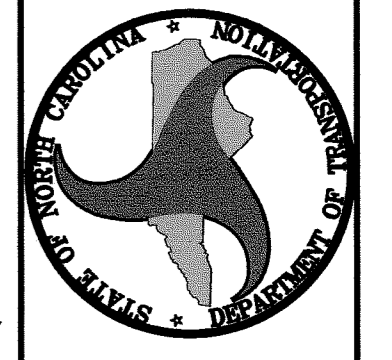

Washington County US-64
 Rest Area/ Visitor Center
 1248 US-64 EAST,
 PLYMOUTH, NC 27962

PROJECT:

TIP PROJ. NO.	K-5000
WBS NO.	41532.3.1
CONTRACT ID NO.	
FEDERAL ID NO.	NHS-0064(158)

REVISIONS:

NO.	DATE

DATE ISSUED: 10/9/12
 DRAWN BY: AS
 CHECKED BY: VB
 SHEET NO.

A8
 8 OF 12

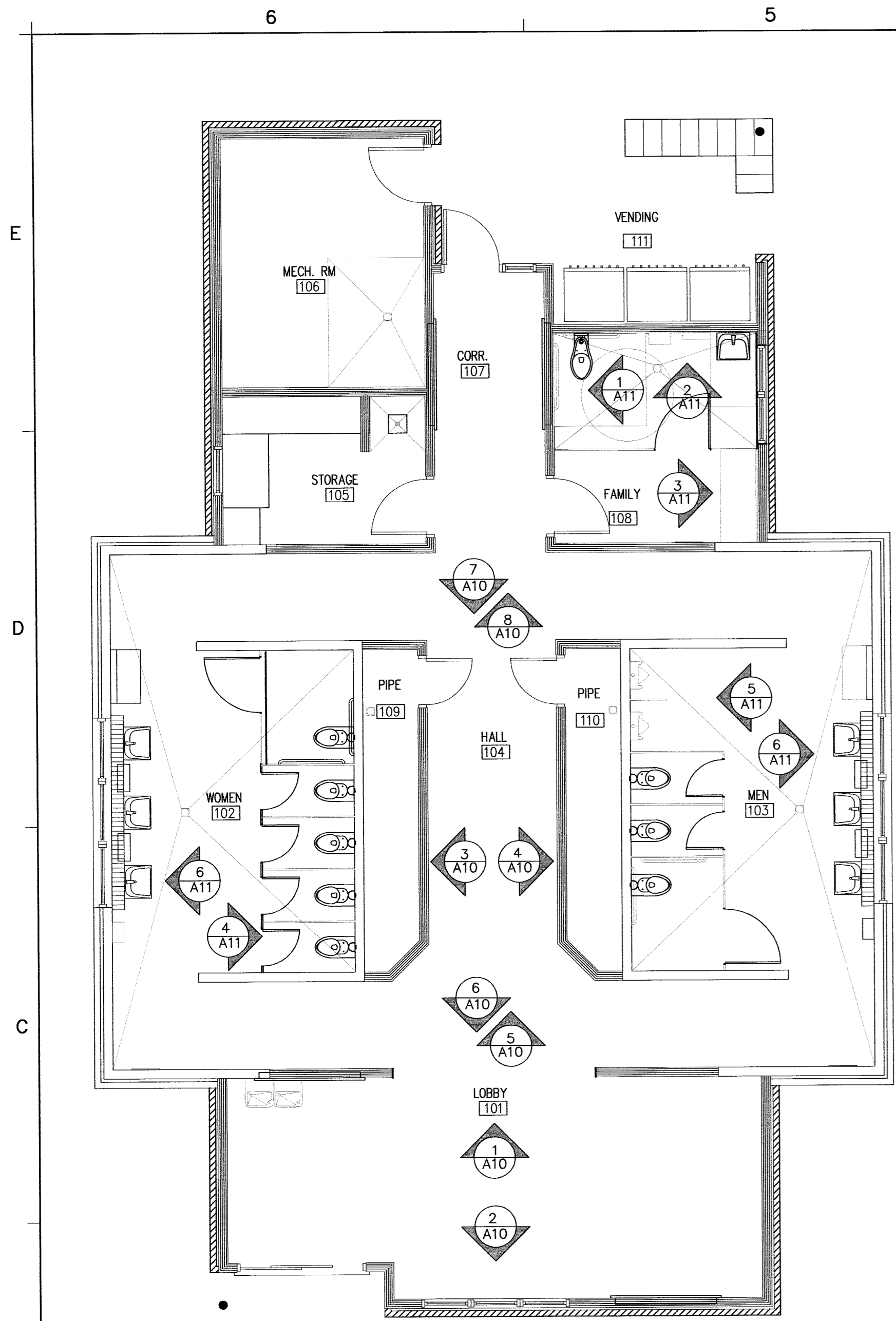

6 KEY PLAN
SCALE: NTS

ROOM FINISH - COLOR SCHEDULE

ROOM	NO.	FLOOR		BASE		NORTH WALL		EAST WALL		SOUTH WALL		WEST WALL		CEILING		REMARKS	
		MAT.	COLOR	MAT.	COLOR	MATERIAL	COLOR	MATERIAL	COLOR	MATERIAL	COLOR	MATERIAL	COLOR	MAT.	COLOR		HEIGHT
LOBBY	101	SEE SPEC.	SEE SPEC.	SEE SPEC.	SEE SPEC.	SEE DETAIL 2/A9	SEE SPEC.	SEE DETAIL 1/A9	SEE SPEC.	SEE DETAIL 2/A9	SEE SPEC.	SEE DETAIL 1/A9	SEE SPEC.	GWB	SEE SPEC.	SEE SHEET A4	
WOMEN	102					SEE DETAIL 3/A9		SEE DETAIL 3/A9 *		SEE DETAIL 3/A9		SEE DETAIL 3/A9					*SEE DETAIL 4/A9 FOR PLUMBING CHASE WALL MATERIALS
MEN	103					SEE DETAIL 3/A9		SEE DETAIL 3/A9 *		SEE DETAIL 3/A9		SEE DETAIL 3/A9					*SEE DETAIL 4/A9 FOR PLUMBING CHASE WALL MATERIALS
HALL	104					SEE REMARKS		SEE DETAIL 2/A9		SEE REMARKS		SEE DETAIL 2/A9					SEE ELEV. 5/A10 THRU 8/A10 FOR WALL MATERIALS SCHEME; SEE DETAILS 1/A9 THRU 3/A9 FOR MATERIALS DESCRIPTION
STORAGE	105					GWB, PAINTED		GWB, PAINTED		GWB, PAINTED		GWB, PAINTED					
MECHANICAL ROOM	106	SEALED CONC.	-	-	-	GWB, PAINTED		GWB, PAINTED		GWB, PAINTED		GWB, PAINTED					
CORRIDOR	107	SEE SPEC.	SEE SPEC.	SEE SPEC.	SEE SPEC.	N/A (OPENS TO HALL)	N/A	SEE DETAIL 2/A9		GWB - SEE REMARKS	N/A	SEE DETAIL 2/A9					5" CEDAR TRIM AROUND STOREFRONT FRAME, 12" CEDAR BAND @ 7'-9" AFF
FAMILY TOILET	108					SEE DETAIL 3/A9	SEE SPEC.	SEE DETAIL 3/A9	SEE SPEC.	SEE DETAIL 3/A9	SEE SPEC.	SEE DETAIL 3/A9	SEE SPEC.				
PIPE CHASE	109	SEALED CONC.	-	-	-	GWB	N/A	GWB	N/A	GWB	N/A	GWB	N/A				
PIPE CHASE	110	SEALED CONC.	-	-	-	GWB	N/A	GWB	N/A	GWB	N/A	GWB	N/A				
VENDING PORCH	111	SEALED CONC.	-	-	-	-	-	-	-	-	-	-	-	FC			

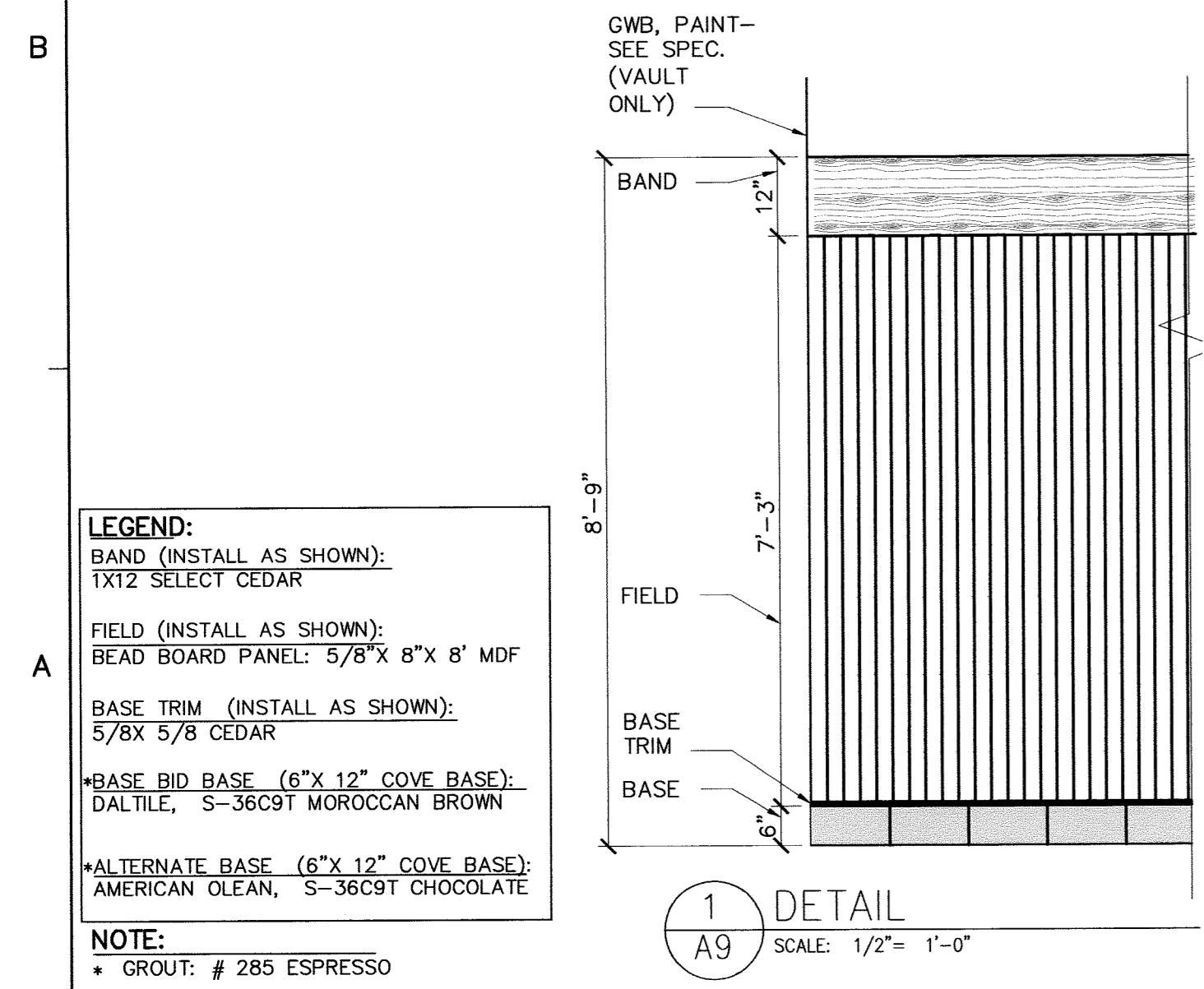

1 DETAIL
SCALE: 1/2" = 1'-0"

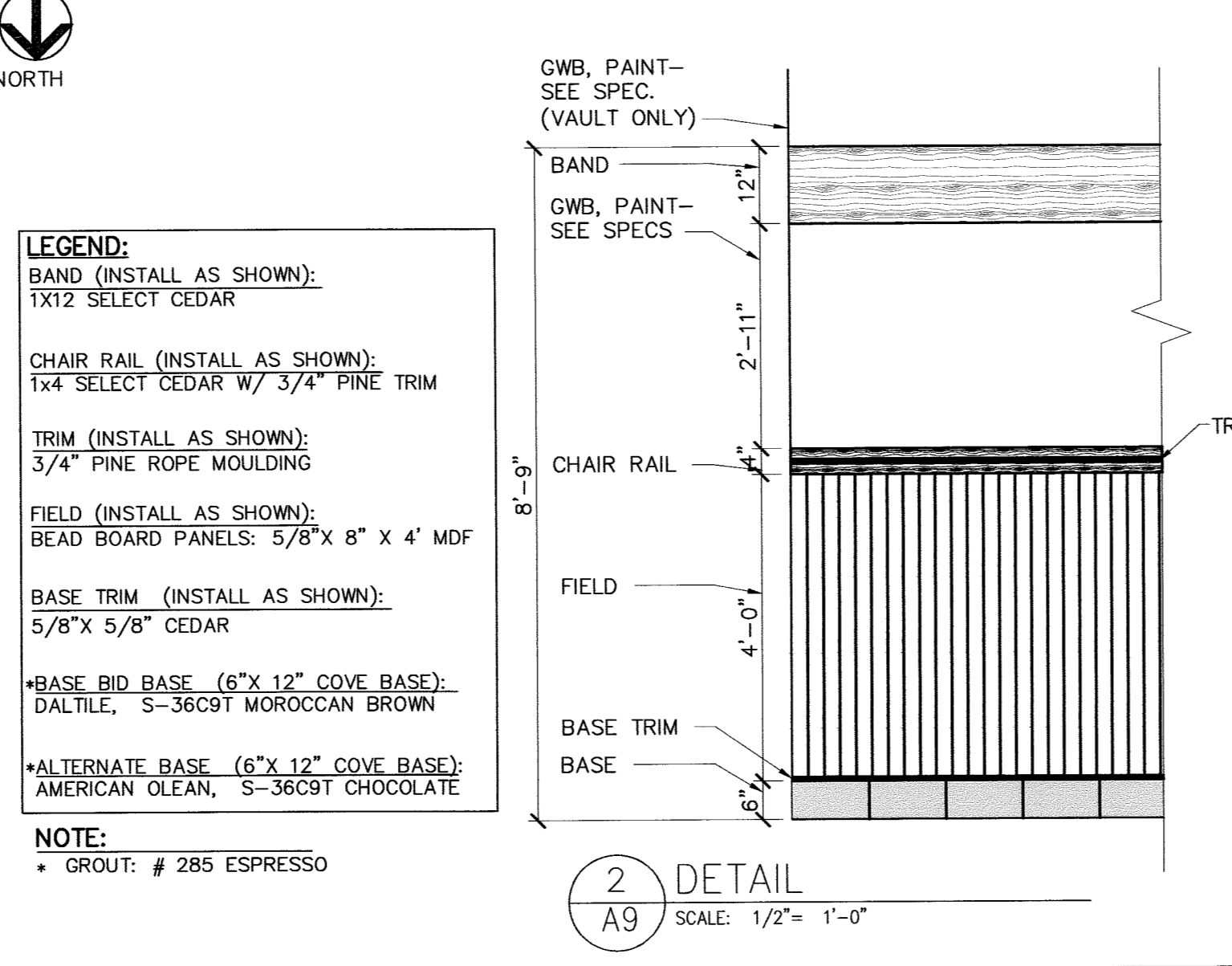

2 DETAIL
SCALE: 1/2" = 1'-0"

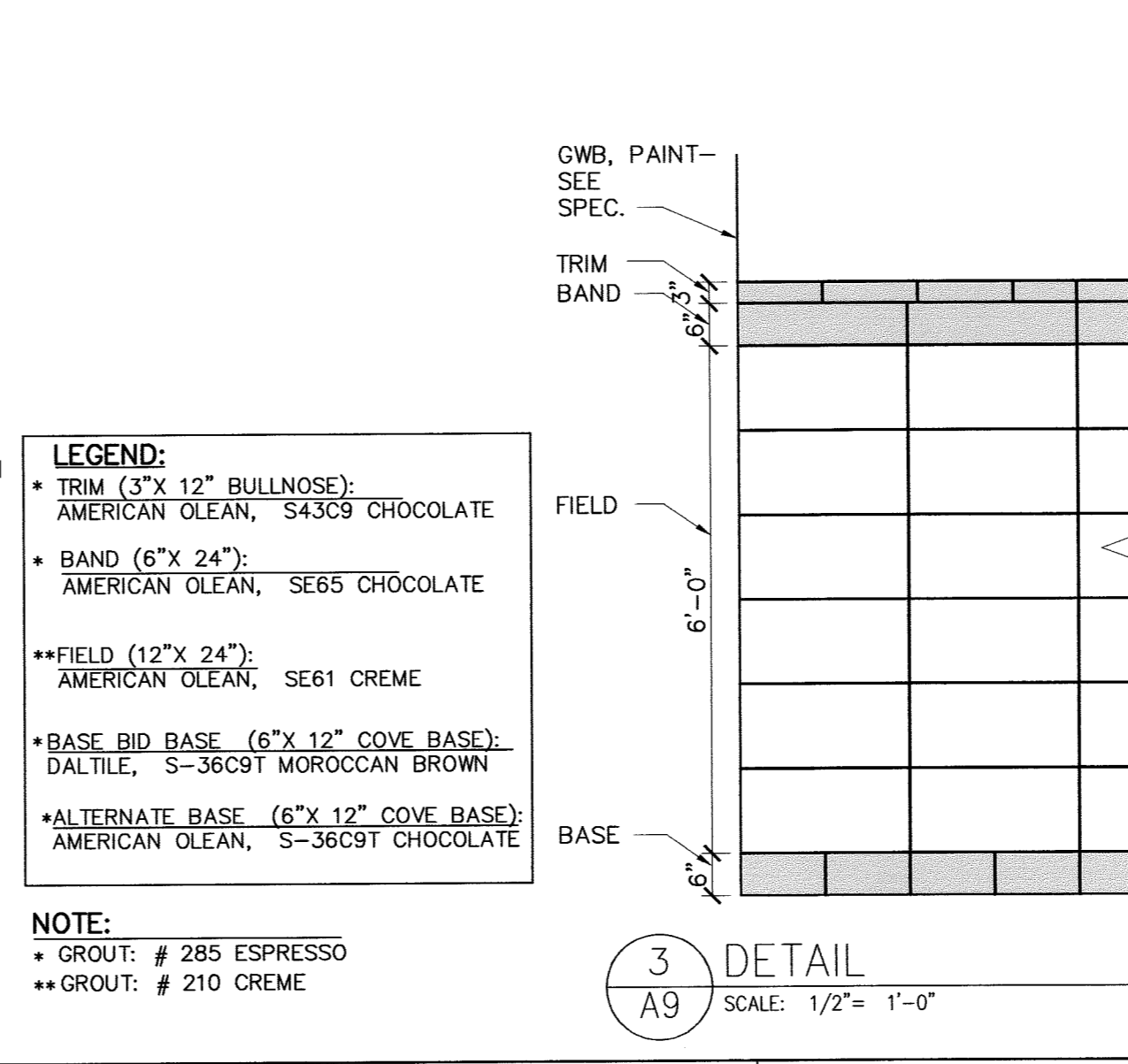

3 DETAIL
SCALE: 1/2" = 1'-0"

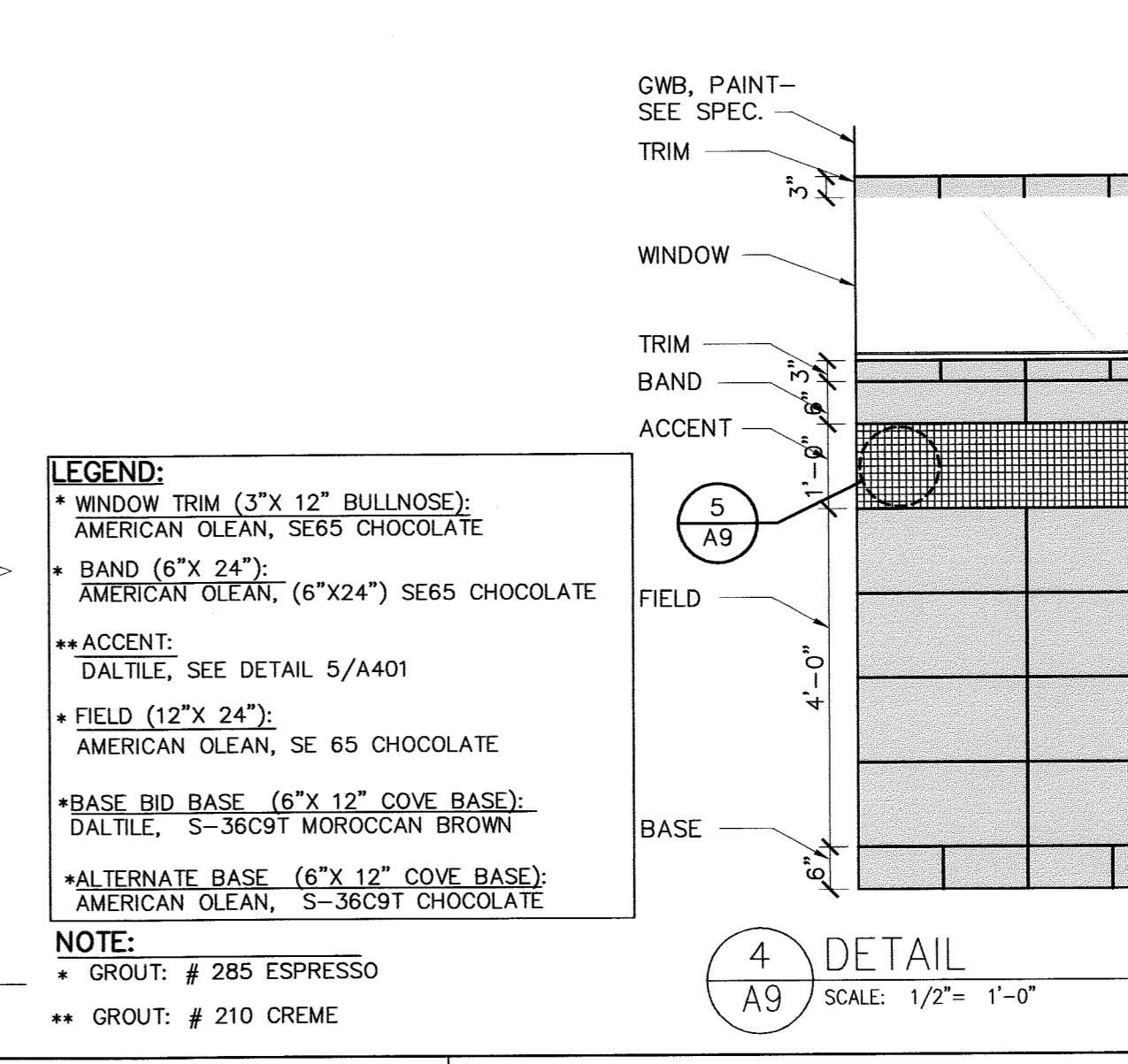

4 DETAIL
SCALE: 1/2" = 1'-0"

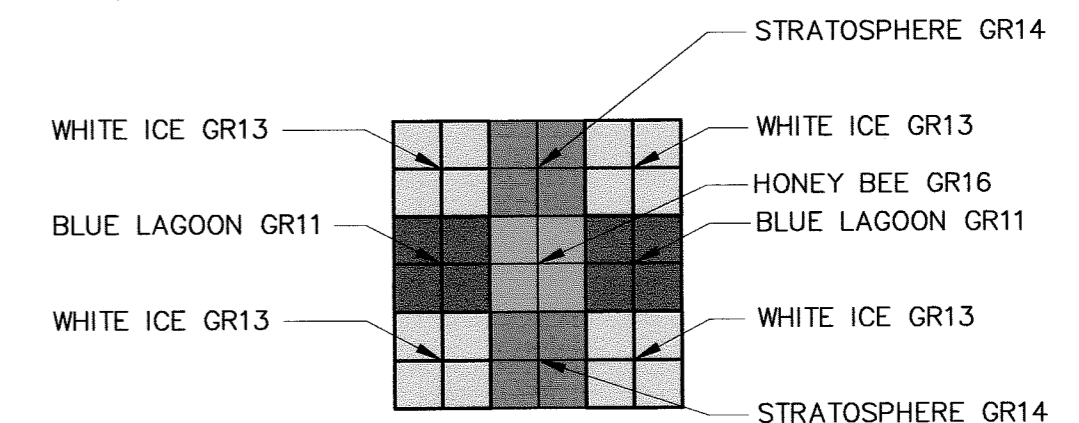

NOTES:
 1. MATERIAL: DAL TILE, 1"X 1" GLASS REFLECTIONS SOLIDS.
 2. PATTERN MADE OF 2X2 SQUARES OF THE SAME COLOR, AS INDICATED ABOVE. SEE SPECS.

5 ACCENT BAND DETAIL
SCALE: NTS

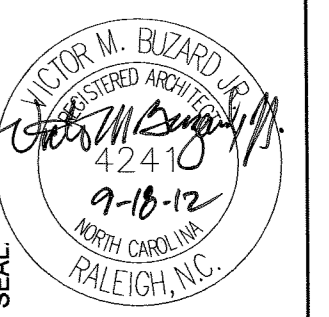

FACILITIES DESIGN ARCHITECTS & ENGINEERS
 FACILITIES MANAGEMENT DIVISION, NCDOT
 1 SOUTH WILMINGTON STREET
 919.715-0400 FAX: 919.715-0399
 RALEIGH, NORTH CAROLINA 27601

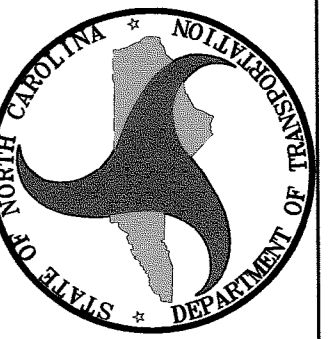

Washington County US-64 Rest Area/ Visitor Center
 1248 US-64 EAST,
 PLYMOUTH, NC 27962

PROJECT: **Washington County US-64 Rest Area/ Visitor Center**

TIP PROJ. NO.	K-5000
WBS NO.	41532.3.1
CONTRACT ID NO.	
FEDERAL ID NO.	NHS-0064(158)
REVISIONS NO.	DATE
DATE ISSUED:	10/9/12
DRAWN BY:	
CHECKED BY:	
SHEET NO.	A9

9 OF 12

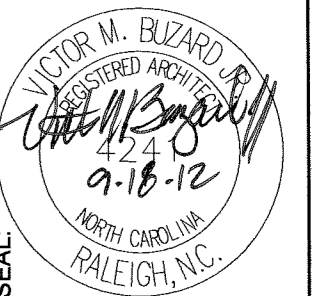
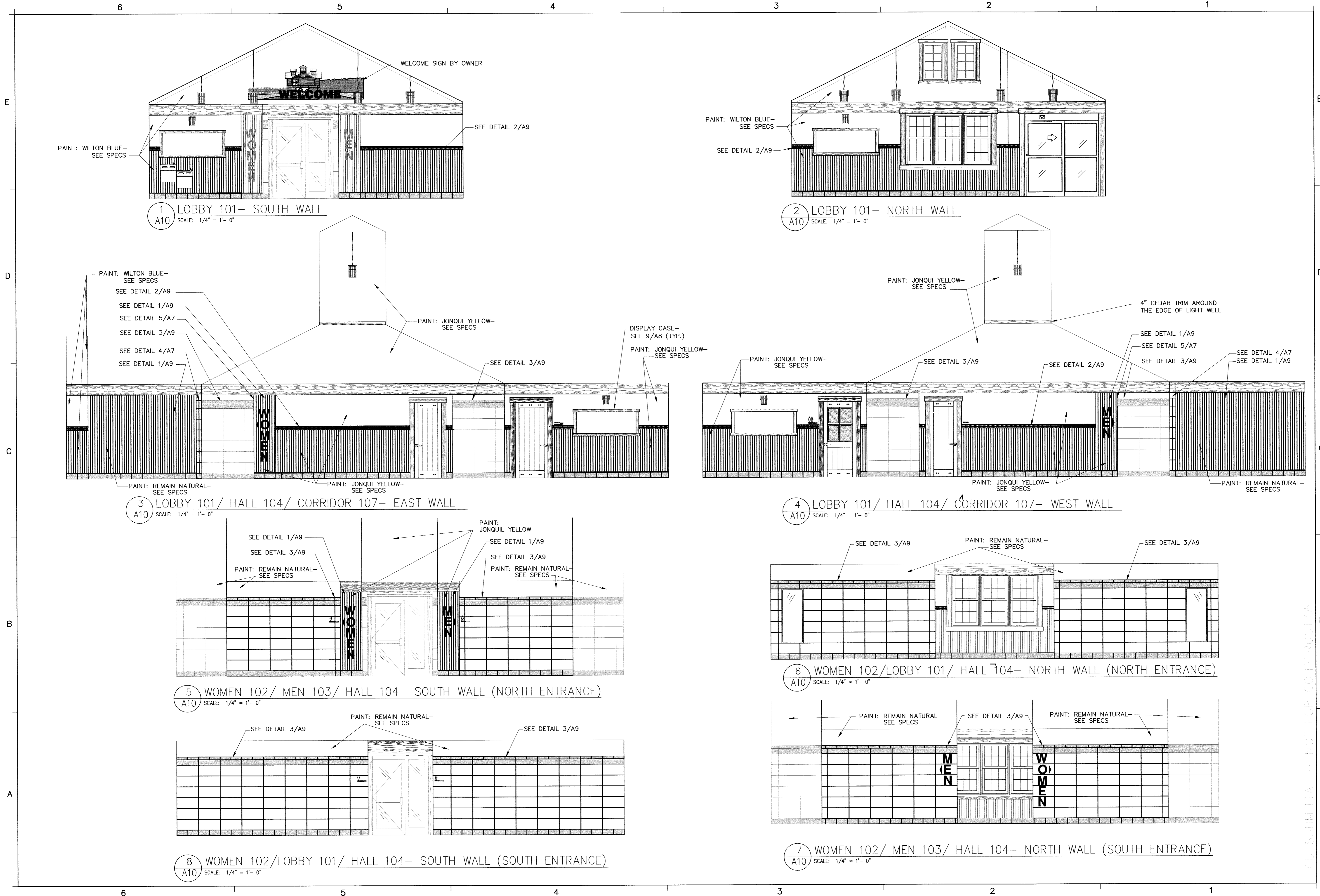

FACILITIES DESIGN
 ARCHITECTS & ENGINEERS
 FACILITIES MANAGEMENT DIVISION, NCDOT
 1 SOUTH WILMINGTON STREET
 919/715-0400 FAX: 919/715-0399
 RALEIGH, NORTH CAROLINA 27601

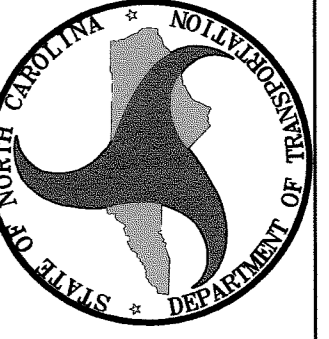

Washington County US-64
 Rest Area/ Visitor Center
 1248 US-64 EAST,
 PLYMOUTH, NC 27962

PROJECT:

TIP PROJ. NO.	K-5000
WBS NO.	41532.3.1
CONTRACT ID NO.	
FEDERAL ID NO.	NHS-0064(158)
REVISIONS NO.	DATE

DATE ISSUED: 10/9/12
 DRAWN BY:
 CHECKED BY:
 SHEET NO.

A10
 10 OF 12

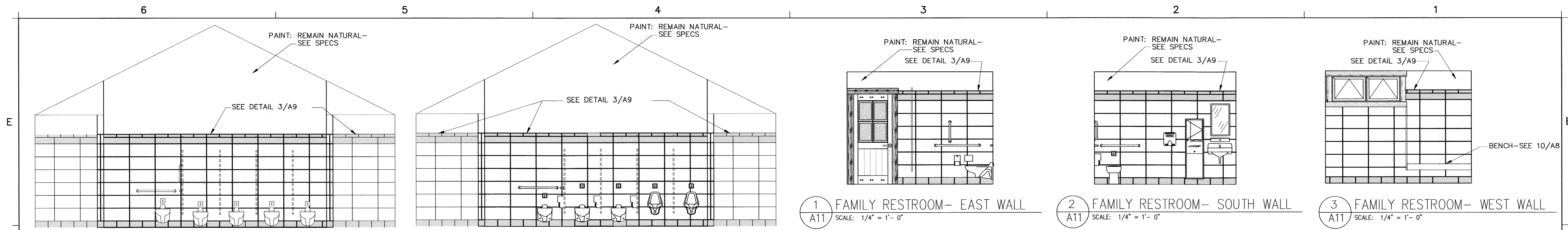

4 WOMEN 102
A11 SCALE: 1/4" = 1'-0"

5 MEN 103
A11 SCALE: 1/4" = 1'-0"

1 FAMILY RESTROOM- EAST WALL
A11 SCALE: 1/4" = 1'-0"

2 FAMILY RESTROOM- SOUTH WALL
A11 SCALE: 1/4" = 1'-0"

3 FAMILY RESTROOM- WEST WALL
A11 SCALE: 1/4" = 1'-0"

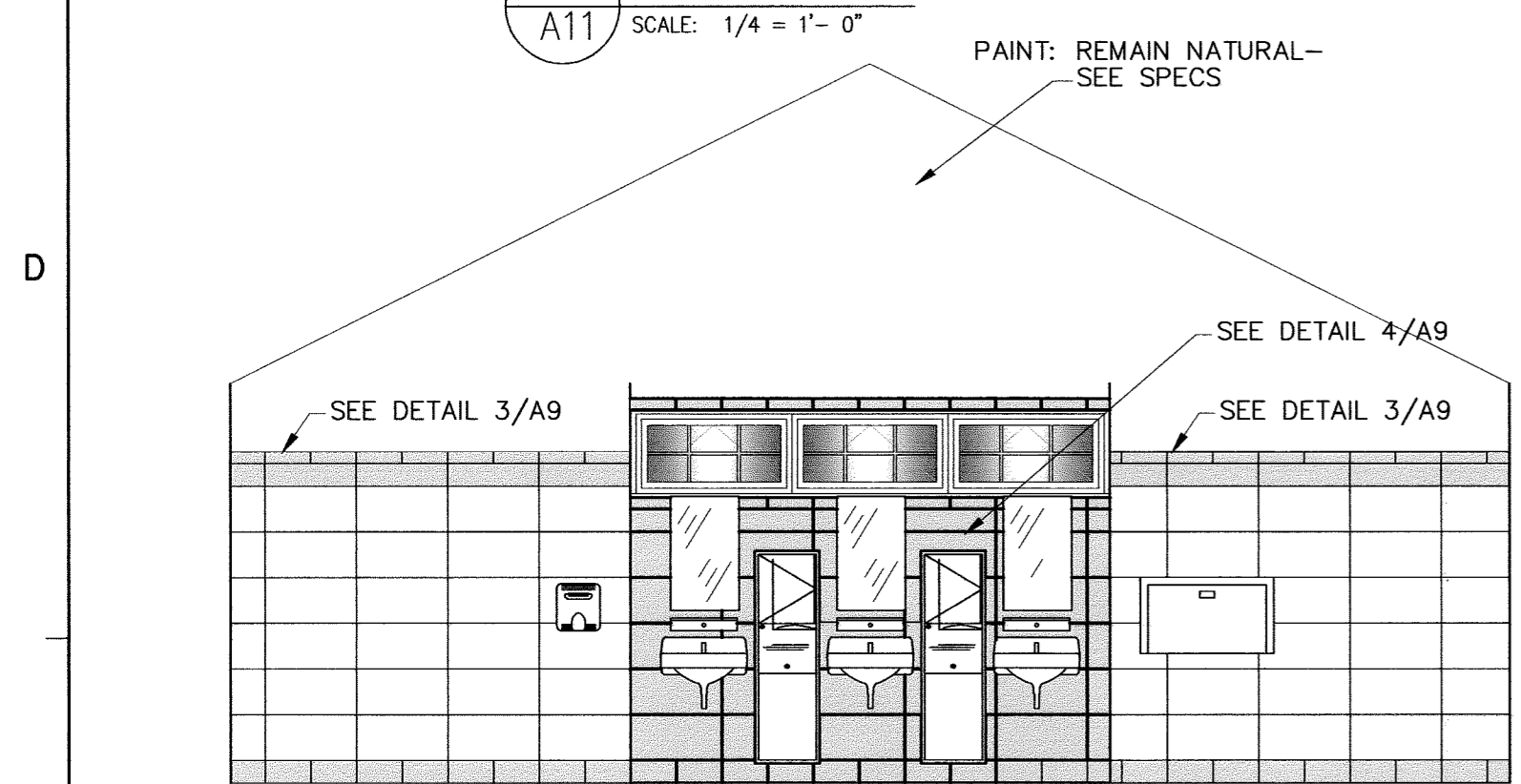

6 WOMEN 102/ MEN 103
A11 SCALE: 1/4" = 1'-0"

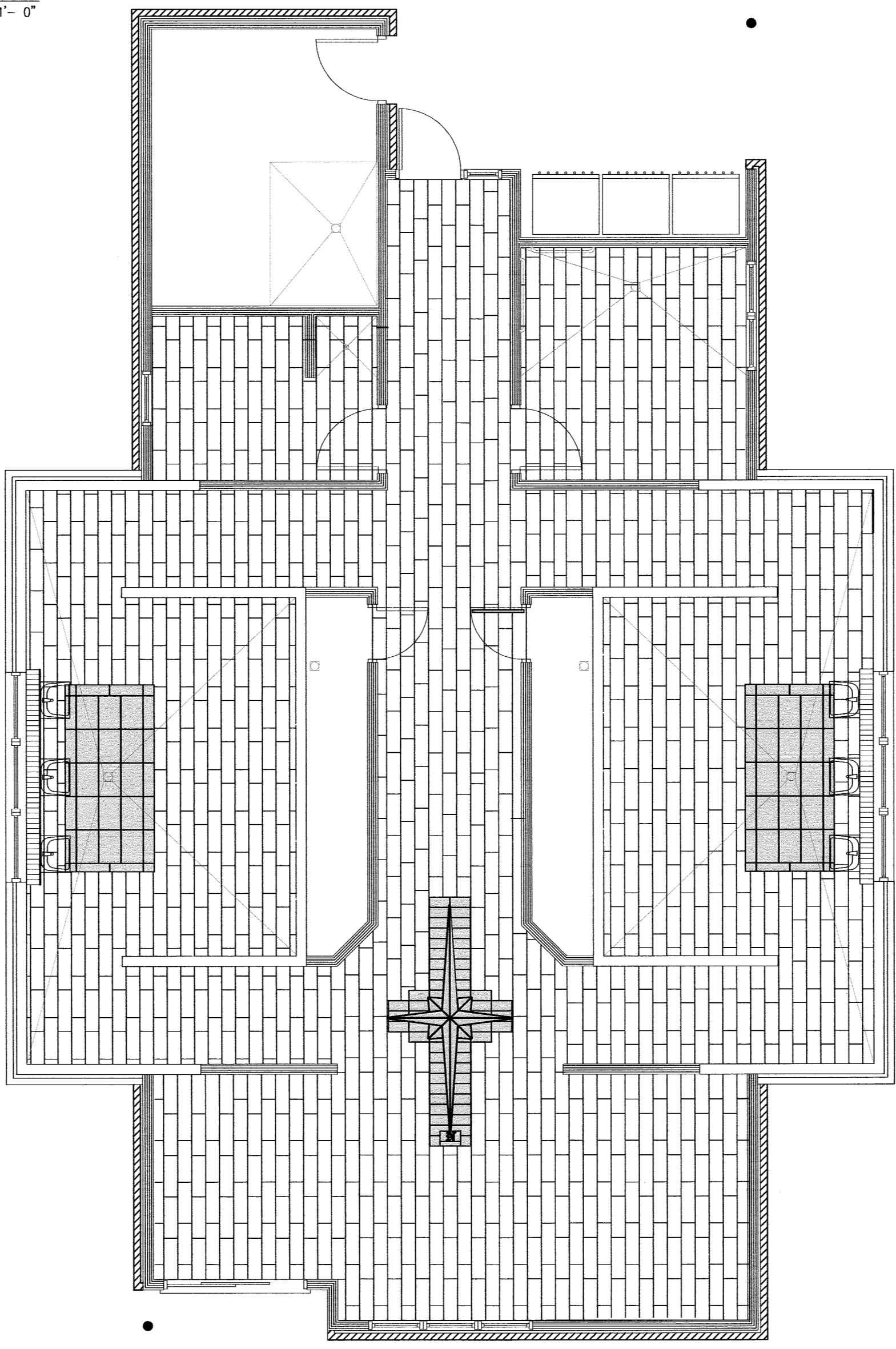

LEGEND- LOBBY AND HALL:
FIELD (8"X 24"):
DAL TILE, ESPRESSO P614

ACCENT:
SEE DETAIL 7a/A11

NOTE:
*GROUT: # 285 ESPRESSO

LEGEND- WOMEN AND MEN:
FIELD (8"X 24"):
DAL TILE, ESPRESSO P614

**ACCENT:
SEE DETAIL 7b/A11

NOTE:
*GROUT: # 285 ESPRESSO
**GROUT: # 560 SEA BLUE

7 FLOOR PATTERN- ALTERNATE
A11 SCALE: 1/4" = 1'-0"

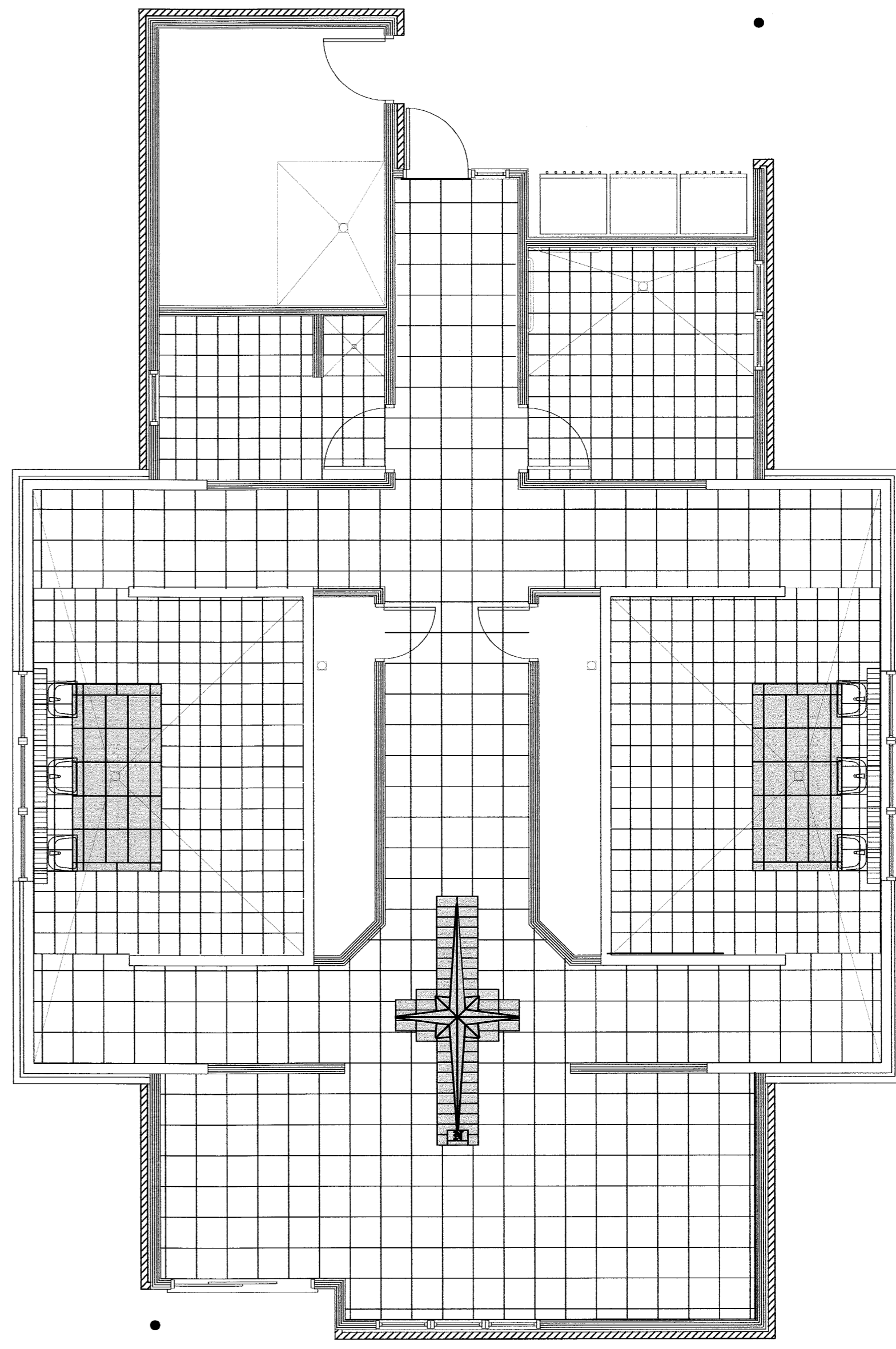

LEGEND- LOBBY AND HALL:
FIELD (18"X 18"):
DAL TILE, MORROCAN BROWN CS55

ACCENT:
SEE DETAIL 7aA11.

NOTE:
*GROUT: # 285 ESPRESSO

LEGEND- WOMEN, MEN, STORAGE & FAMILY:
FIELD (12"X 12"):
DAL TILE, MORROCAN BROWN CS55

**ACCENT (WOMEN & MEN):
SEE DETAIL 7b/A11

NOTE:
*GROUT: # 285 ESPRESSO
**GROUT: # 560 SEA BLUE

7 FLOOR PATTERN- BASE BID
A11 SCALE: 1/4" = 1'-0"

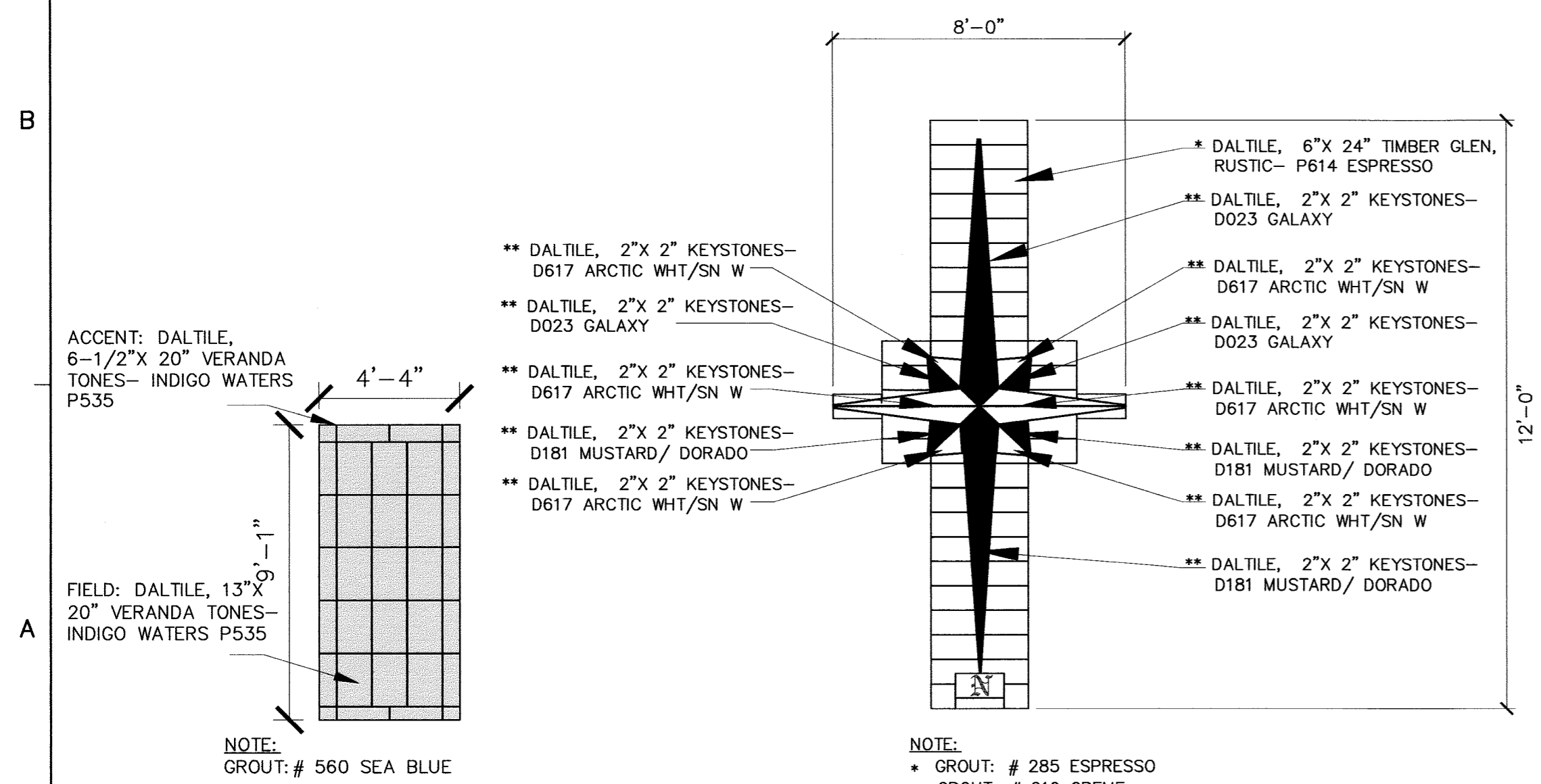

7b DETAIL- FLOOR ACCENT TILE
A11 SCALE: 1/4" = 1'-0"

7a DETAIL- COMPASS MEDALLION
A11 SCALE: 3/8" = 1'-0"

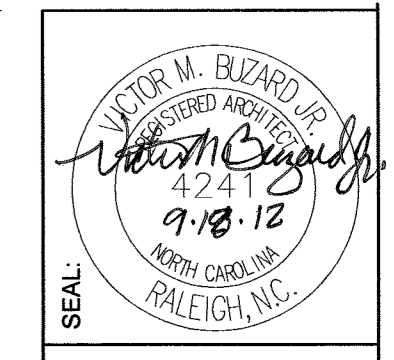

FACILITIES DESIGN
ARCHITECTS & ENGINEERS
FACILITIES MANAGEMENT DIVISION, NCDOT
1 SOUTH WILMINGTON STREET
919/715-0400 FAX 919/715-0399
RALEIGH, NORTH CAROLINA 27601

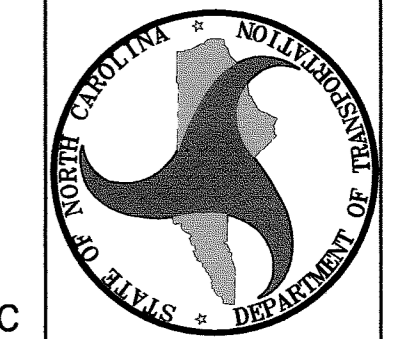

Washington County US-64
Rest Area/ Visitor Center
1248 US-64 EAST,
PLYMOUTH, NC 27962

PROJECT:

TIP PROJ. NO.	K-5000
WBS NO.	41532.3.1
CONTRACT ID NO.	
FEDERAL ID NO.	NHS-0064(158)
REVISIONS NO.	DATE

DATE ISSUED:	10/9/12
DRAWN BY:	
CHECKED BY:	
SHEET NO.	A11

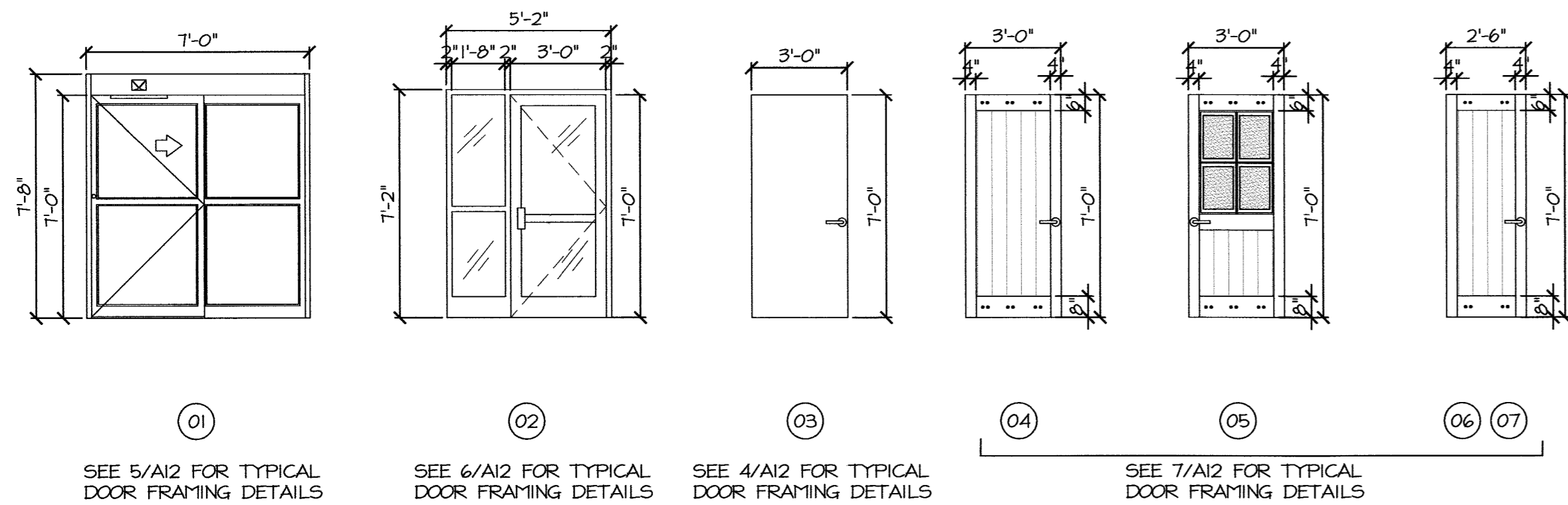

1 DOOR ELEVATIONS
A12 SCALE: 1/4" = 1'-0"

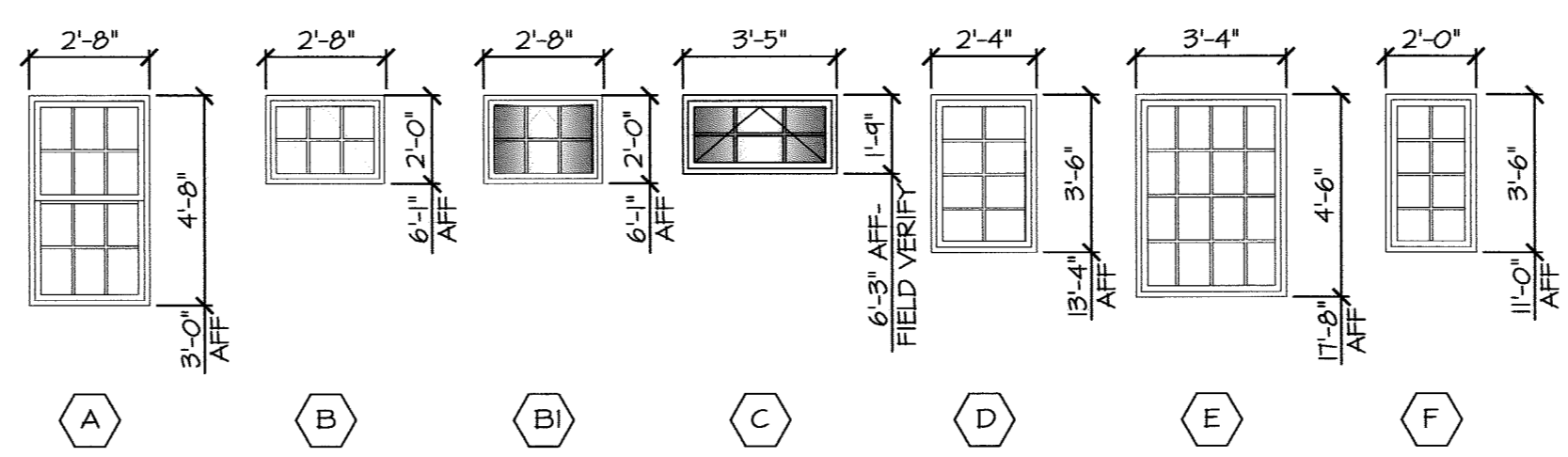

NOTES:
1. SPECIFIED DIMENSIONS ARE FOR WINDOW ROUGH OPENING.
2. SEE 1/A12 FOR TYP. WINDOW FRAMING DETAILS.
3. SEE 3/A12 FOR RM. 102 & 103 WINDOWS FRAMING (WINDOW TYPE "C" - NEW WINDOWS TO REPLACE EXISTING).

2 WINDOW ELEVATIONS
A12 SCALE: 1/4" = 1'-0"

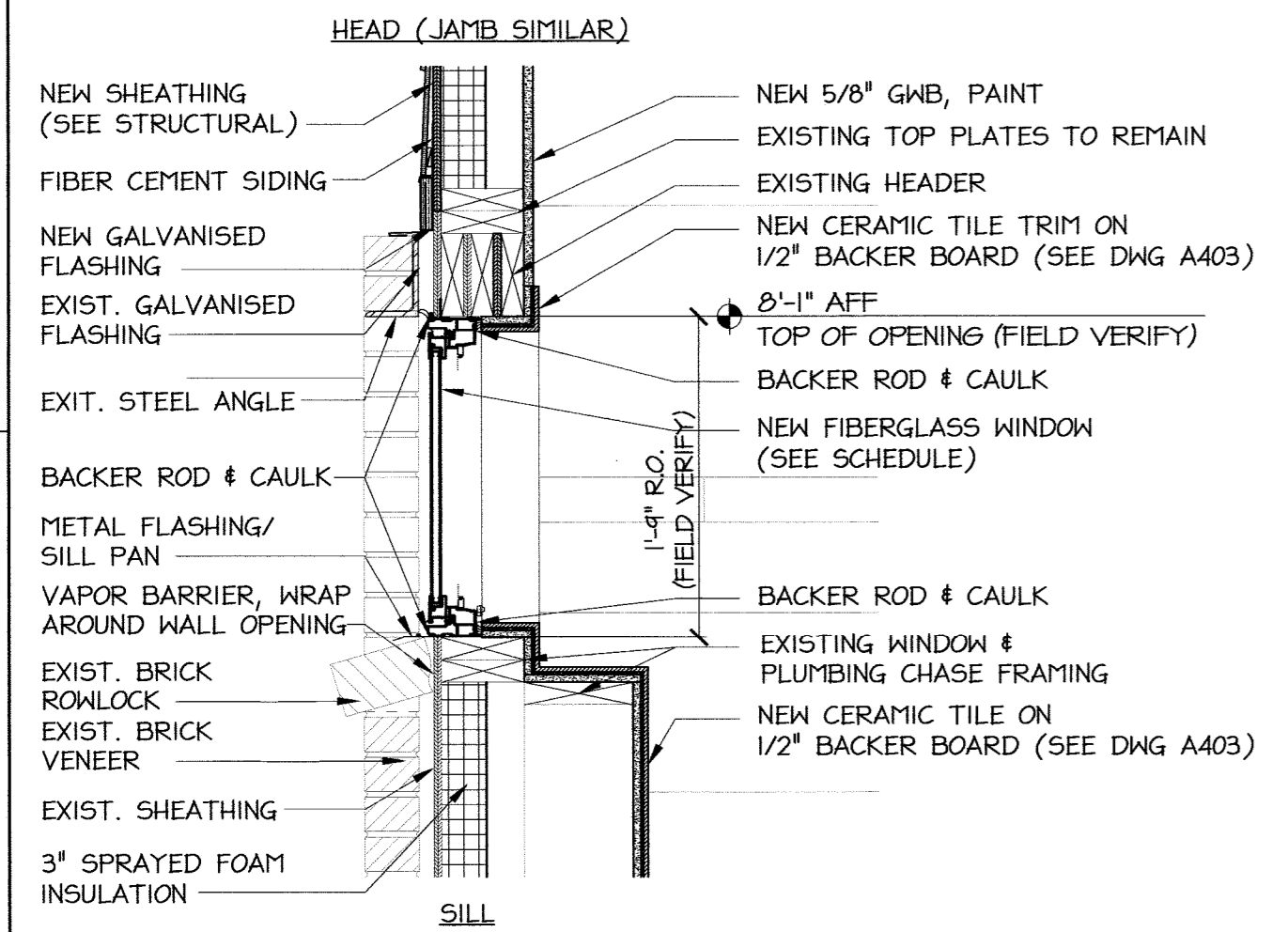

3 RESTROOM WINDOW DETAIL
A12 SCALE: 1" = 1'-0"

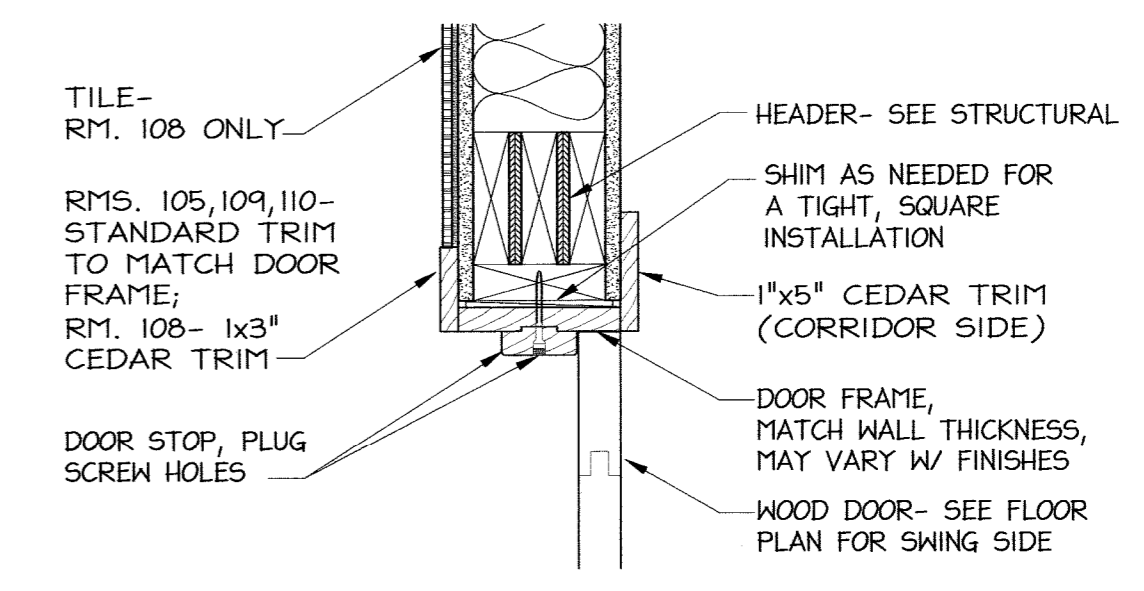

7 WOOD DOOR FRAME DETAIL
A12 SCALE: 1-1/2" = 1'-0"

DOOR-HARDWARE SCHEDULE										
DOOR		FRAME		HARDWARE			REMARKS			
TYPE	SIZE	MAT.	FINISH	MAT.	FINISH	LOCKSET	HINGES	CLOSER	STOP	KICK PLATE
01	7'-0" x 7'-0"	ALUM. GLASS	CLEAR ANOD.	ALUM.	CLEAR ANOD.	-	-	-	-	-
02	3'-0" x 7'-0" x 3/4"	ALUM.	SEE SPEC.	ALUM.	SEE SPEC.	SEE SPEC.	A512	SEE SPEC.	SEE SPEC.	SEE SPEC.
03	3'-0" x 7'-0" x 3/4"	H.M.	SEE SPEC.	H.M.	SEE SPEC.	SEE SPEC.	A512	SEE SPEC.	SEE SPEC.	SEE SPEC.
04	3'-0" x 7'-0" x 3/4"	WOOD	SEE SPEC.	H.M.	SEE SPEC.	SEE SPEC.	A512	SEE SPEC.	SEE SPEC.	SEE SPEC.
05	3'-0" x 7'-0" x 3/4"	WOOD	SEE SPEC.	H.M.	SEE SPEC.	SEE SPEC.	A512	SEE SPEC.	SEE SPEC.	SEE SPEC.
06	2'-6" x 7'-0" x 3/4"	WOOD	SEE SPEC.	H.M.	SEE SPEC.	SEE SPEC.	A512	SEE SPEC.	SEE SPEC.	SEE SPEC.
07	2'-6" x 7'-0" x 3/4"	WOOD	SEE SPEC.	H.M.	SEE SPEC.	SEE SPEC.	A512	SEE SPEC.	SEE SPEC.	SEE SPEC.

WINDOW SCHEDULE							
MARK	SIZE (R.O.)	TYPE	FRAME			GLAZING	REMARKS
			MATERIAL	FINISH	SCREEN		
A	2'-8" x 4'-8"	DOUBLE-HUNG	FIBERGLASS	WHITE	YES	SEE SPECS	W/ THERMAL BREAK
B	2'-8" x 2'-0"	AWNING	FIBERGLASS	WHITE	YES	SEE SPECS	W/ THERMAL BREAK
C	2'-8" x 2'-0"	AWNING	FIBERGLASS	WHITE	YES	SEE SPECS	W/ THERMAL BREAK
D	3'-5" x 1'-9"	AWNING	FIBERGLASS	WHITE	YES	SEE SPECS	W/ THERMAL BREAK
E	2'-4" x 3'-6"	FIXED	FIBERGLASS	WHITE	NO	SEE SPECS	W/ THERMAL BREAK
F	3'-4" x 4'-6"	FIXED	FIBERGLASS	WHITE	NO	SEE SPECS	W/ THERMAL BREAK
G	2'-0" x 3'-6"	FIXED	FIBERGLASS	WHITE	NO	SEE SPECS	W/ THERMAL BREAK

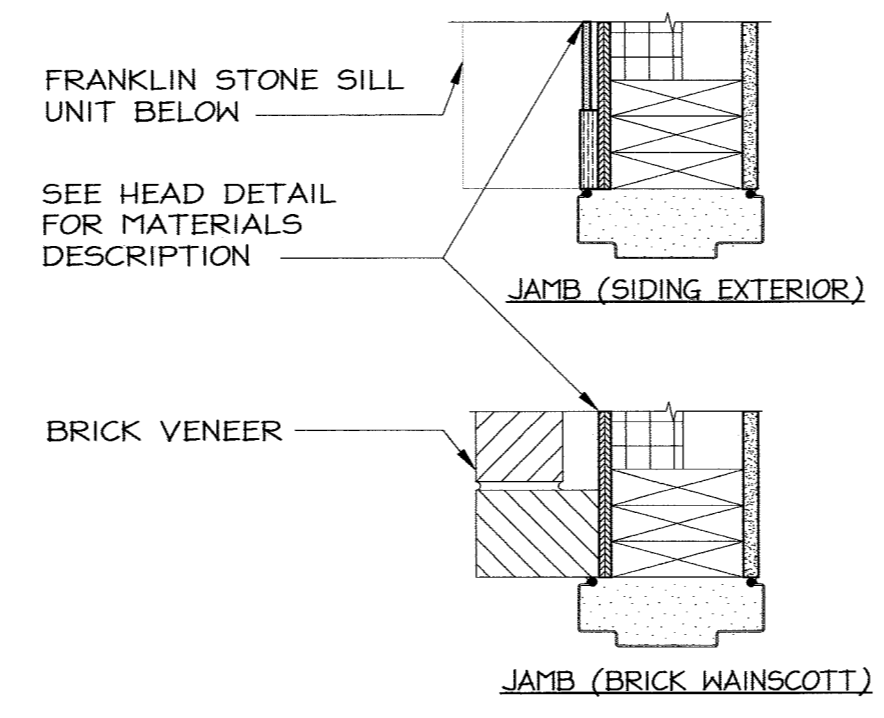
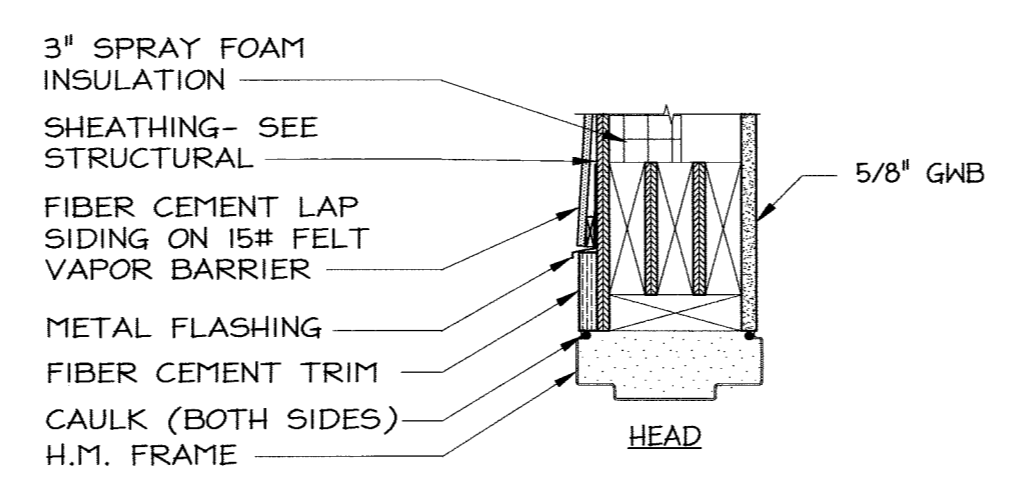

4 MECH. RM DOOR DETAILS
A12 SCALE: 1" = 1'-0"

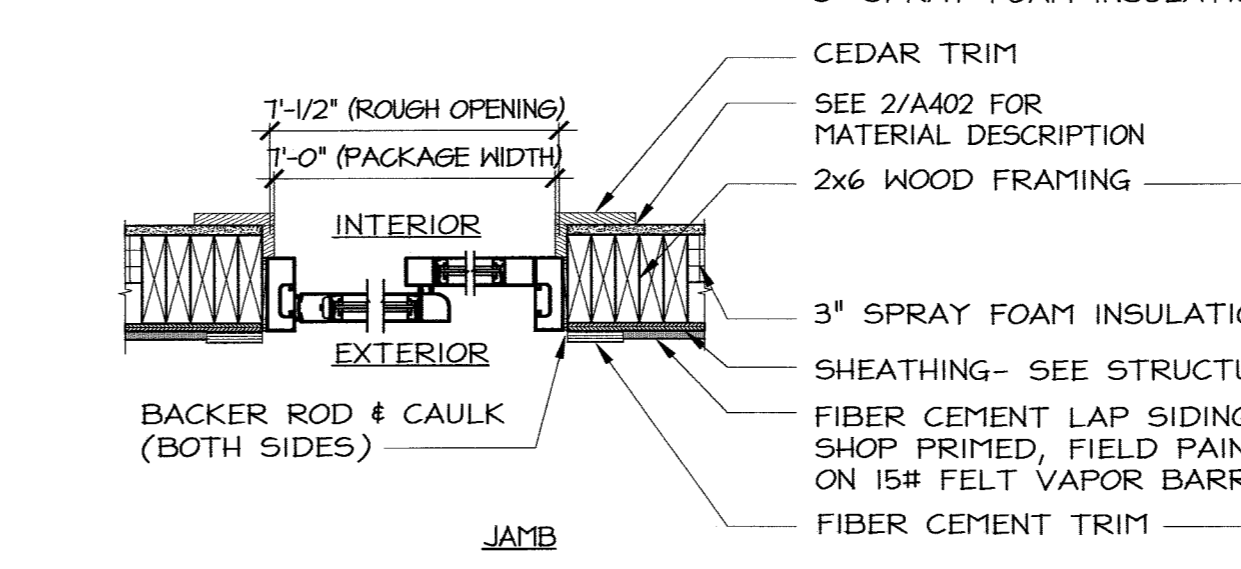
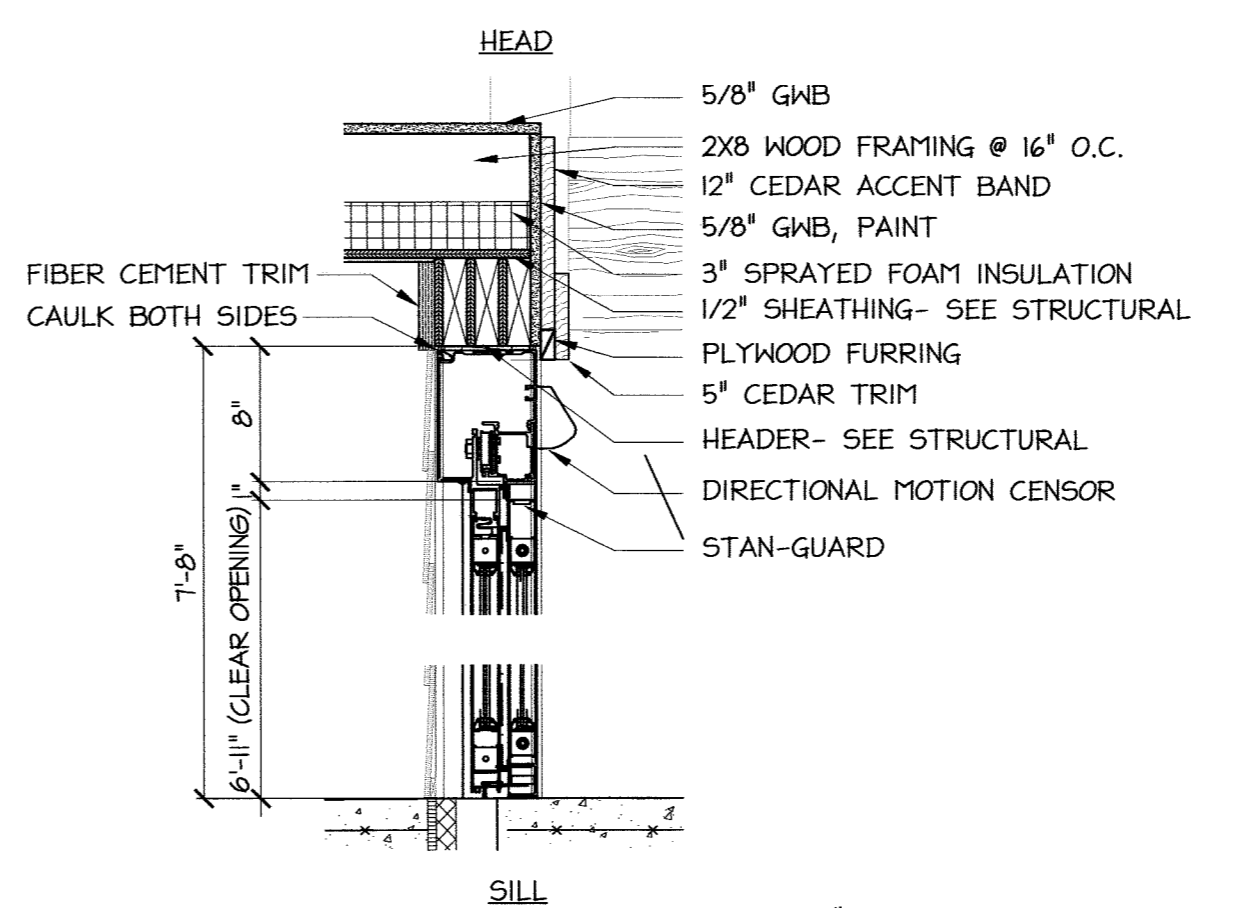

5 FRONT ENTRY DOOR DETAILS
A12 SCALE: 1" = 1'-0"

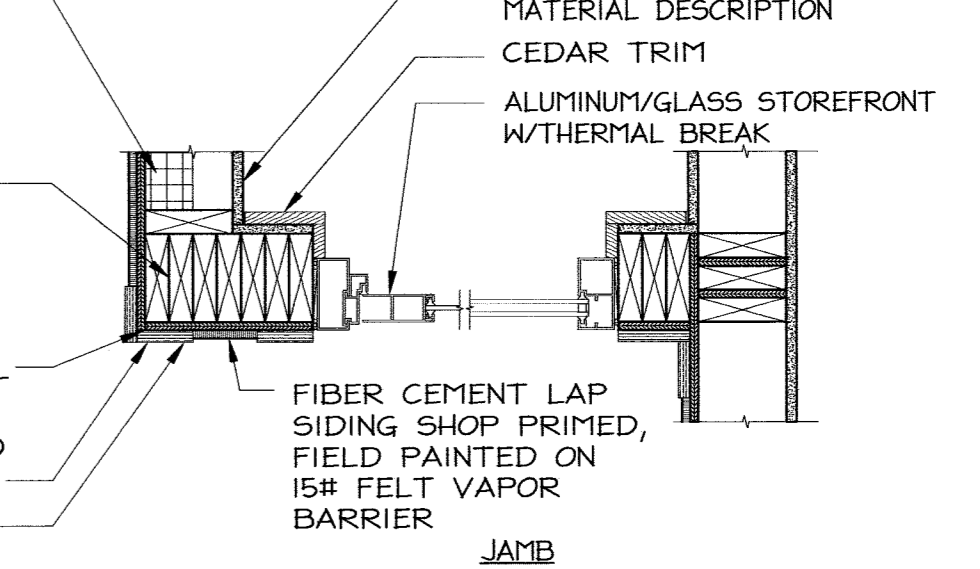
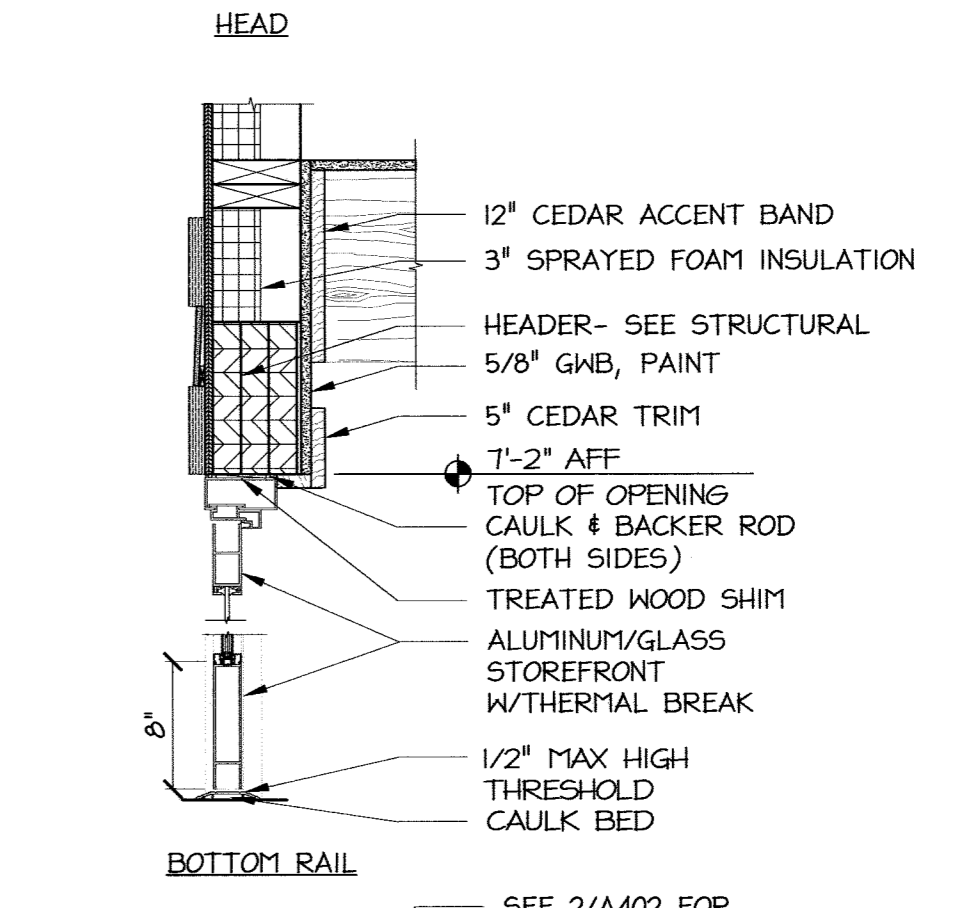

6 REAR ENTRY DOOR DETAILS
A12 SCALE: 1" = 1'-0"

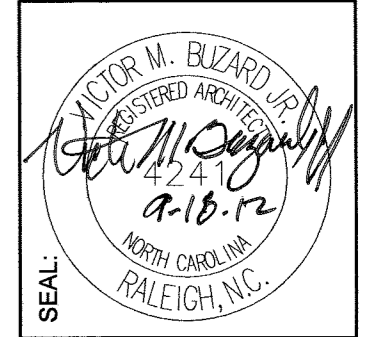

FACILITIES DESIGN
ARCHITECTS & ENGINEERS
FACILITIES MANAGEMENT DIVISION, NCDOT
1 SOUTH WILMINGTON STREET
919/715-0400 FAX: 919/715-0399
RALEIGH, NORTH CAROLINA 27601



PROJECT: Washington County US-64 Rest Area/ Visitor Center
1248 US-64 EAST, PLYMOUTH, NC 27962

TIP PROJ. NO.	K-5000
WBS NO.	41532.3.1
CONTRACT ID NO.	
FEDERAL ID NO.	NHS-0064(158)
REVISIONS NO.	DATE
DATE ISSUED:	10/9/12
DRAWN BY:	AS
CHECKED BY:	VB

SHEET NO. **A12**
12 OF 12

NOTES:

1. CONCRETE STRENGTH FOR FOOTINGS = 3000 PSI.
2. CONCRETE STRENGTH FOR SLABS = 4000 PSI.
3. FLOOR SLAB SHALL BE 4" CONC REINF W/ 6X6-WI.4XW1.4 MINR OVER VAPOR BARRIER ON 4" COMPACTED GRANULAR BASE CONTAINING LESS THAN 2% FINES.
4. VAPOR BARRIER NOT REQUIRED UNDER EXTERIOR SLABS.
5. ELEVATIONS SHOWN ON STRUCTURAL DRAWINGS ARE ABOVE FIRST FINISH FLOOR, REF ELEVATION = +0'-0".
6. SEE ARCH PLANS FOR FLOOR DIMENSIONS, DEPRESSIONS, & FINISHES NOT SHOWN. SEE ARCH OR SITE PLANS FOR EXTERIOR CONCRETE.
7. CONTRACTOR IS RESPONSIBLE FOR COORDINATING ALL TRADES PRIOR TO PLACING SLAB CONCRETE. SEE OTHER DRAWINGS FOR LOCATION OF EMBEDDED ITEMS.
8. TOP OF FOOTING = -1'-4" BELOW FIN FLOOR, UON.
9. ALL REINFORCING STEEL SHALL BE GRADE 60. ALL LAP SPLICES SHALL BE 48 X BAR DIAMETER.
10. C.J DENOTES SLAB CONTROL JOINT. SEE DETAIL 11/S4.
11. SUBMIT SHOP DRAWINGS FOR ALL CONCRETE & MASONRY FASTENERS & FOR TRUSS TIE-DOWN CONNECTORS.
12. ALL POSTS (PX) SHALL BE CONTINUOUS FROM FLOOR TO TOP OF WALL, UON.

FOOTING SCHEDULE		
MARK	SIZE	REINFORCEMENT
a	3'-0" X 5'-4" X 12" THK SLAB	(5) #5 EW
b	4'-0" X 4'-0" X 12"	(4) #5 EW

POST SCHEDULE	
MARK	SIZE
PI	(3) 2X6
P2	5" SCH 40 PIPE

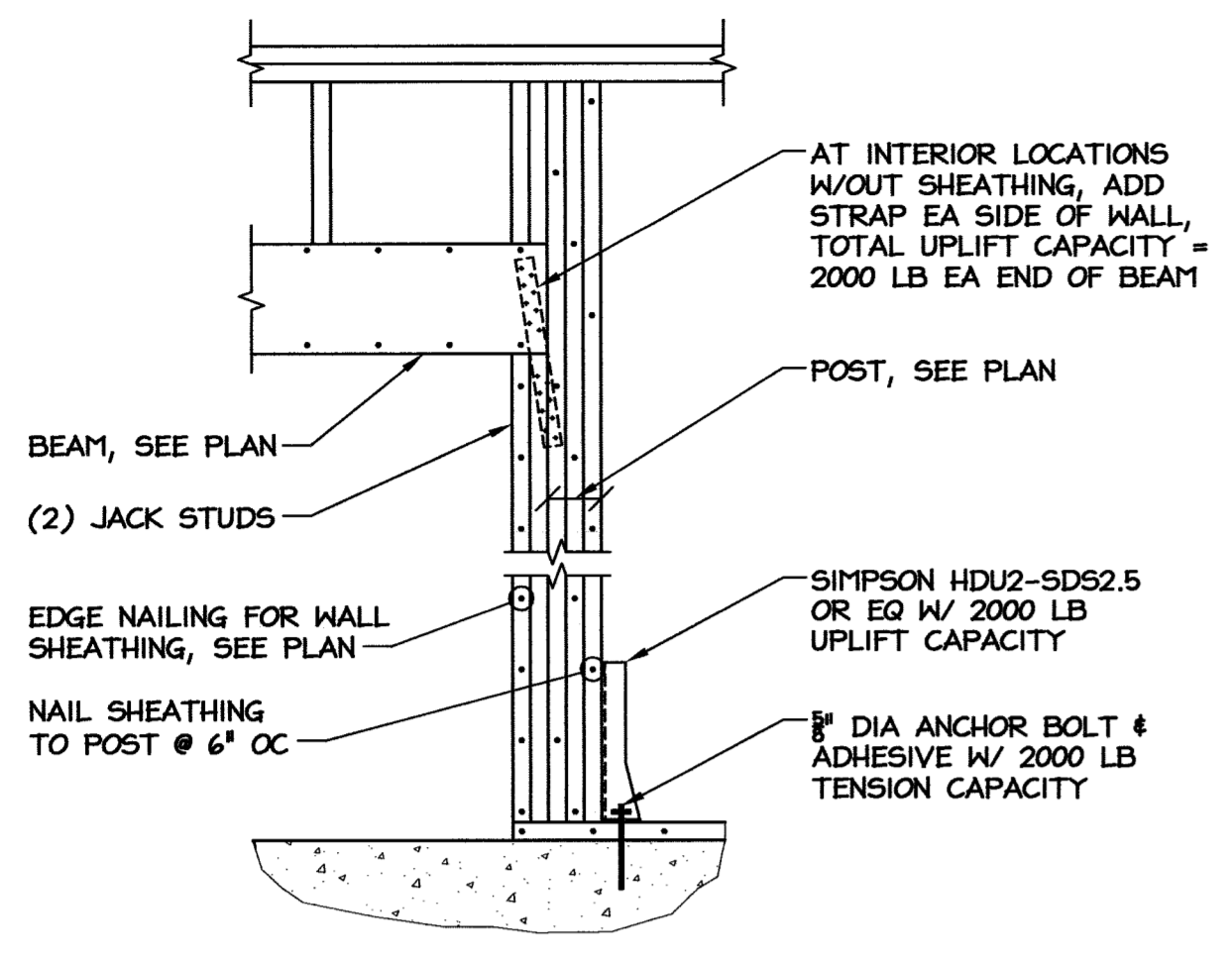

7
SI TYP TIE-DOWN AT POST
SCALE: 3/4" = 1'-0"

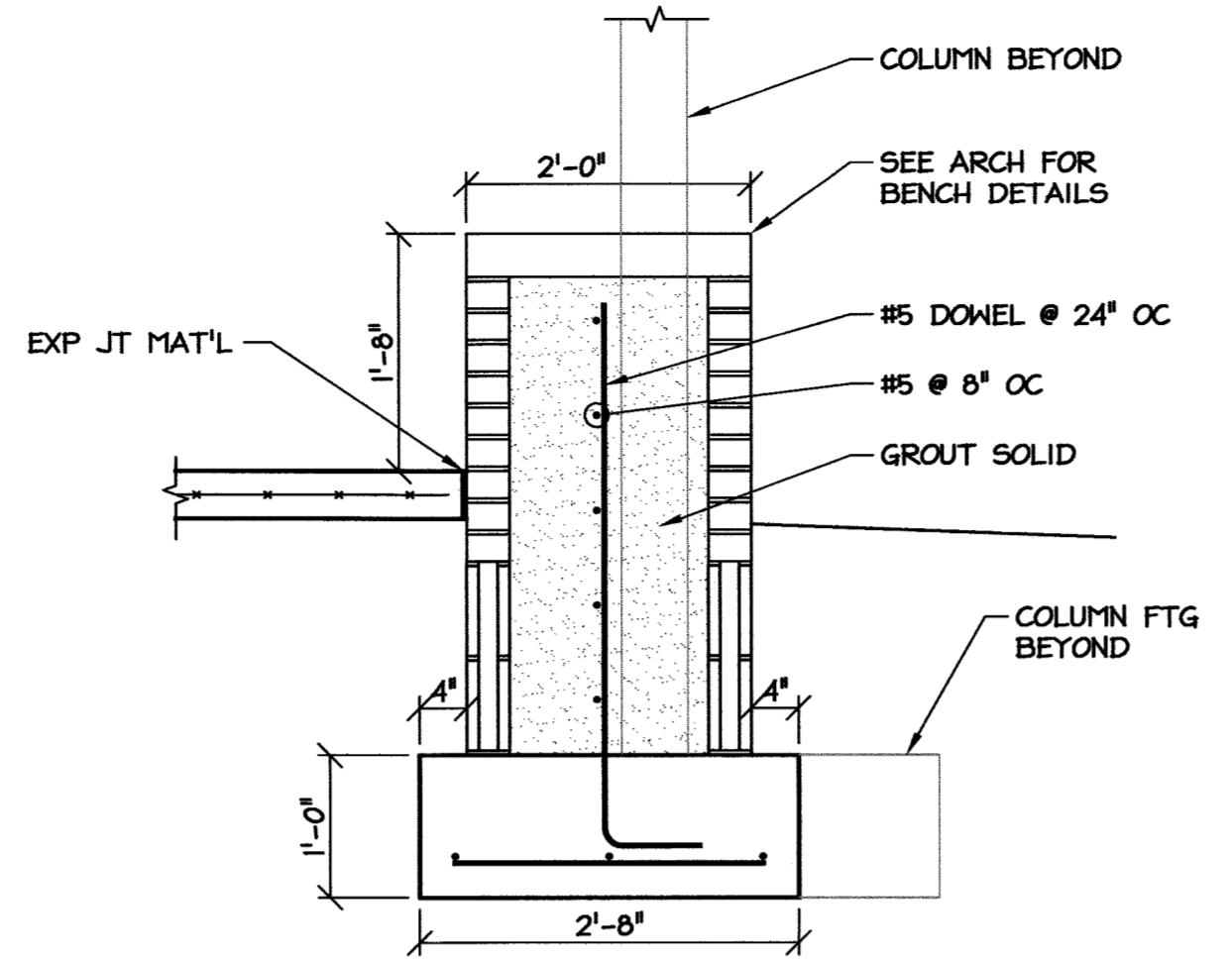

4
SI FOOTING AT BENCH
SCALE: 3/4" = 1'-0"

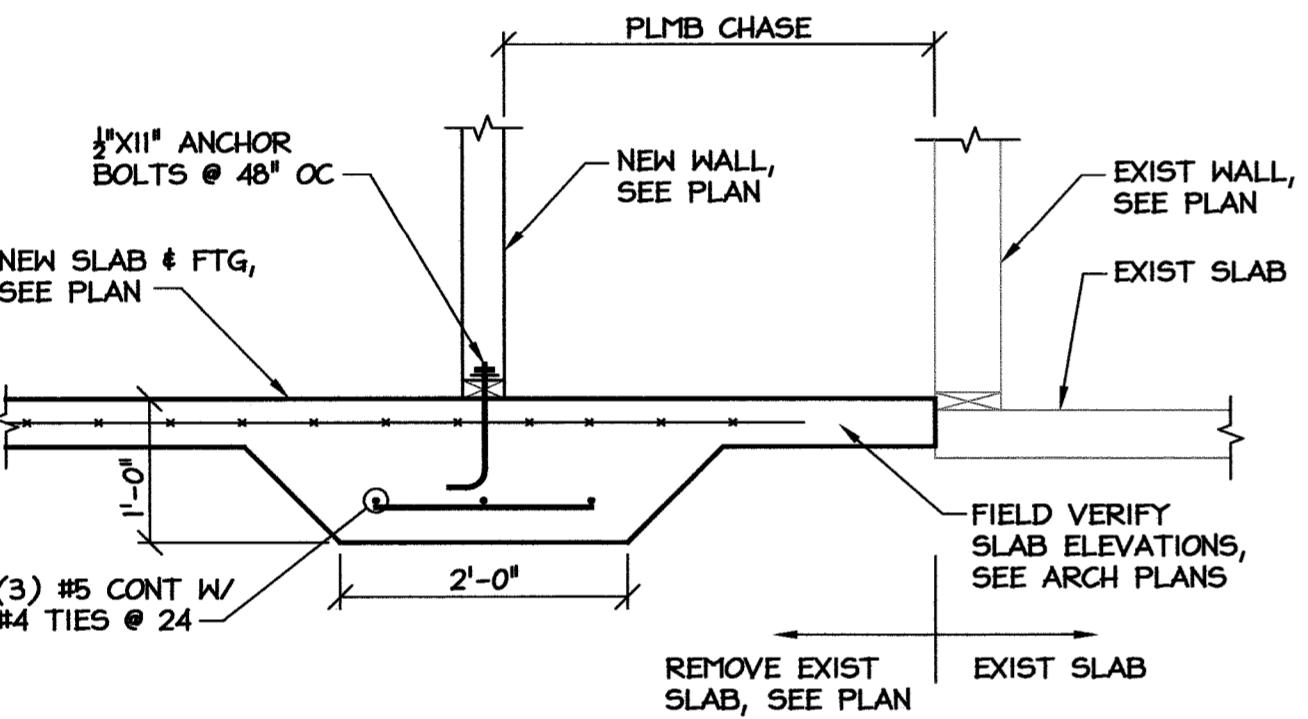

6
SI INT BRG WALL AT CHASE
SCALE: 3/4" = 1'-0"

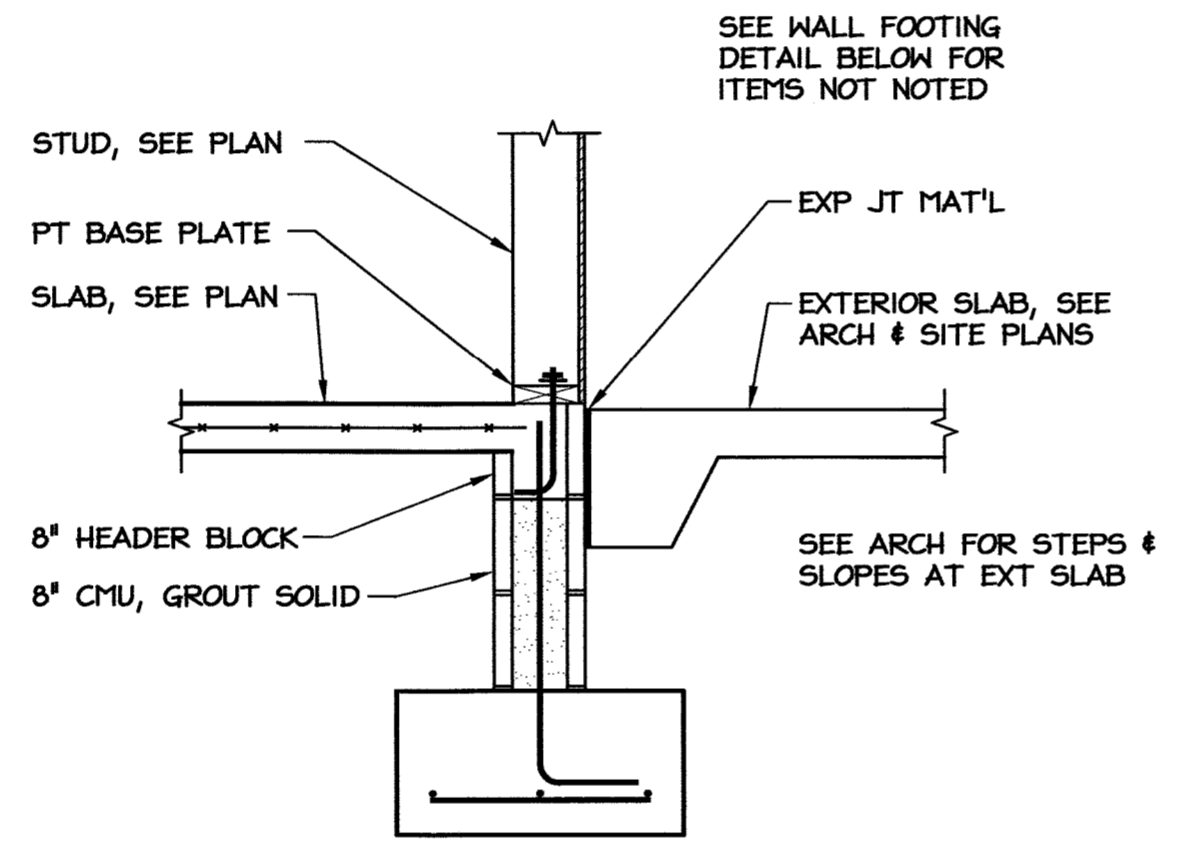

3
SI WALL FOOTING
SCALE: 3/4" = 1'-0"

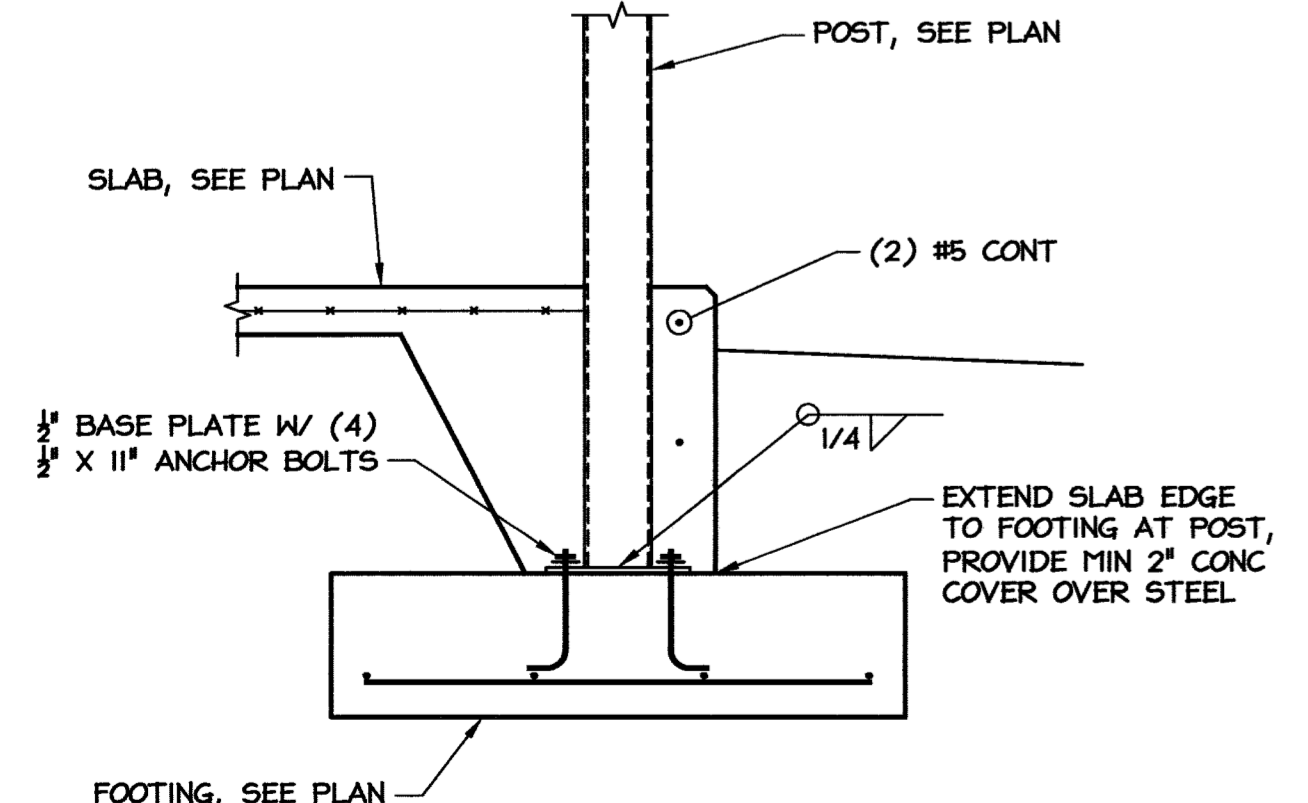

5
SI COLUMN FOOTING
SCALE: 3/4" = 1'-0"

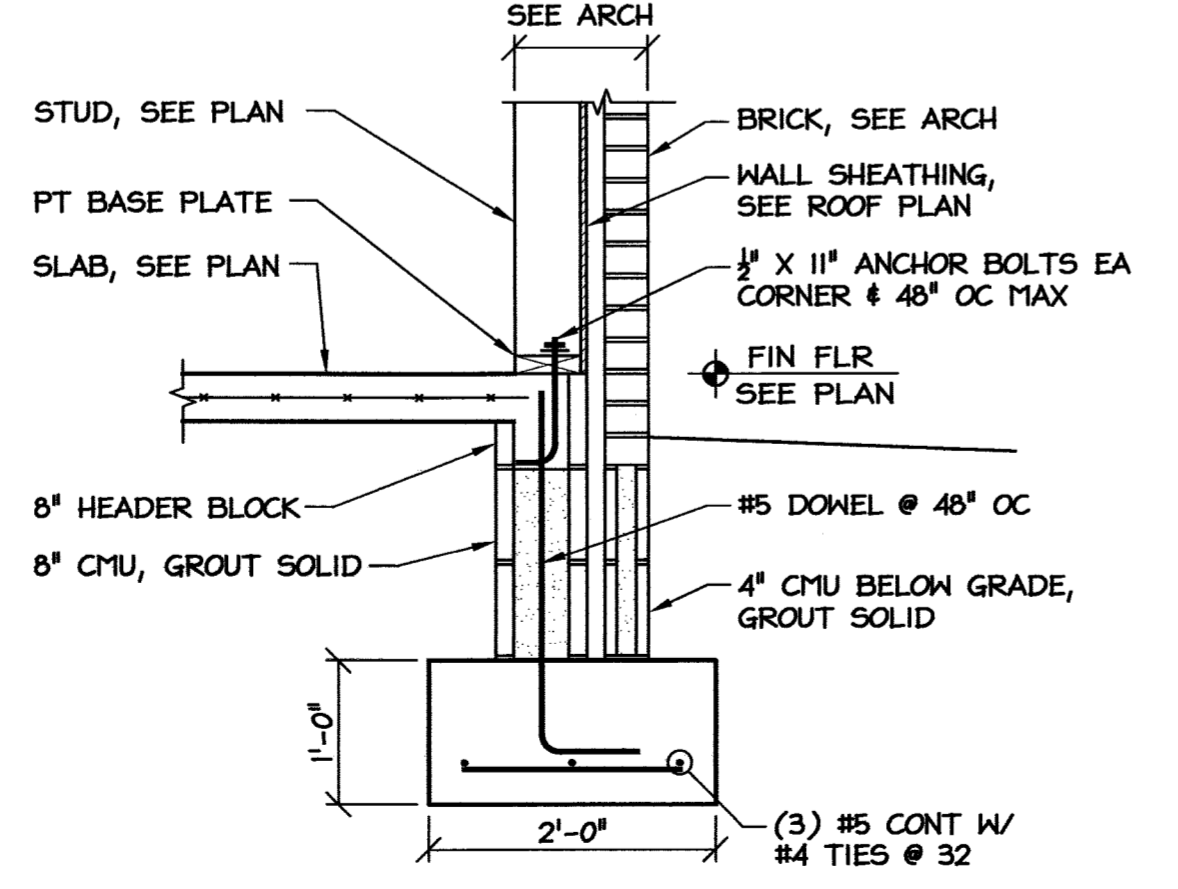

2
SI WALL FOOTING
SCALE: 3/4" = 1'-0"

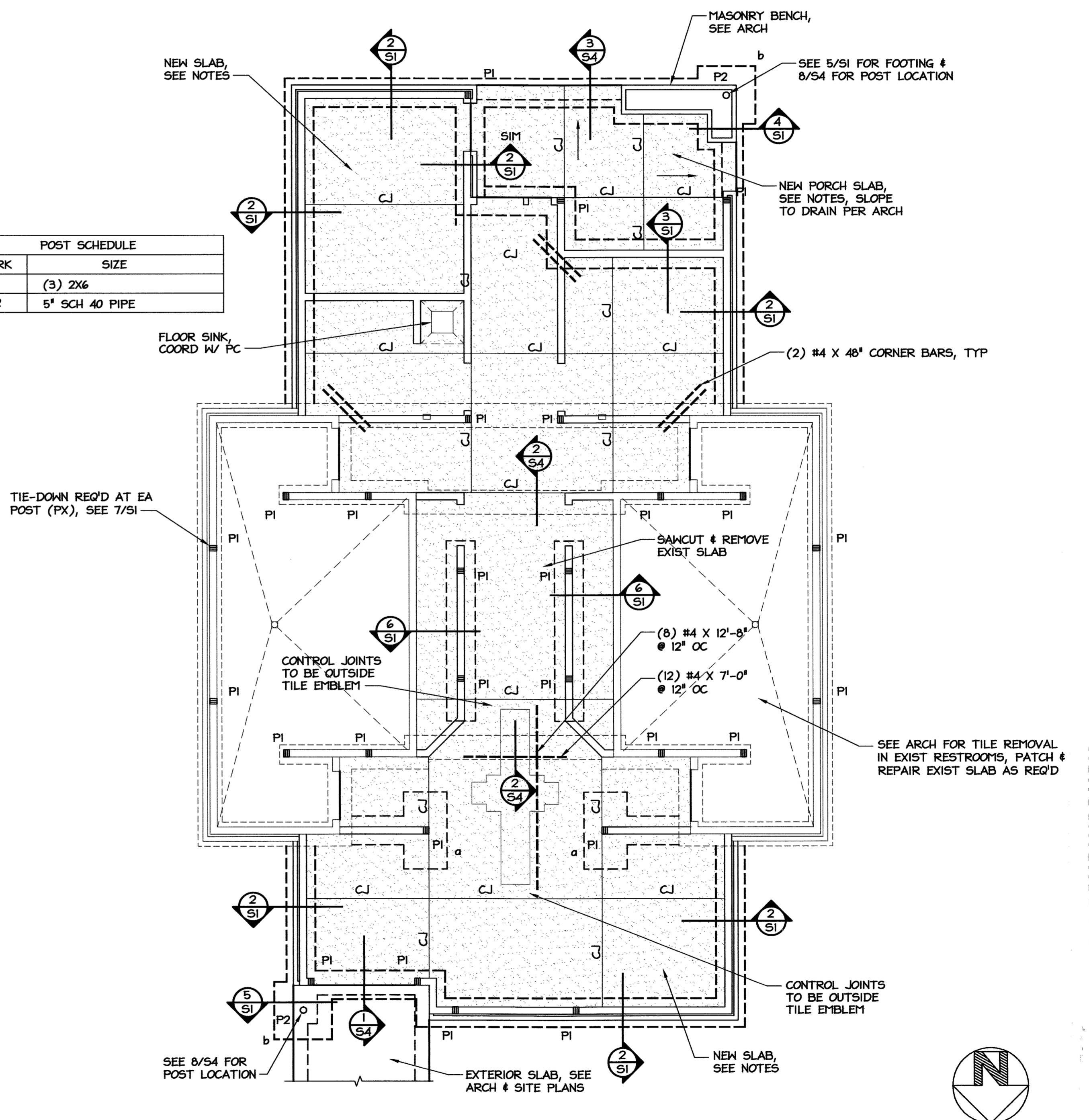

1
SI FOUNDATION PLAN
SCALE: 3/16" = 1'-0"

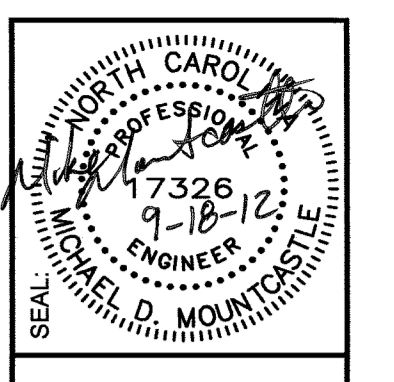

FACILITIES DESIGN
ARCHITECTS & ENGINEERS
FACILITIES MANAGEMENT DIVISION, NCDOT
1 SOUTH WILMINGTON STREET
RALEIGH, NORTH CAROLINA 27601
919/715-0400 FAX: 919/715-0399

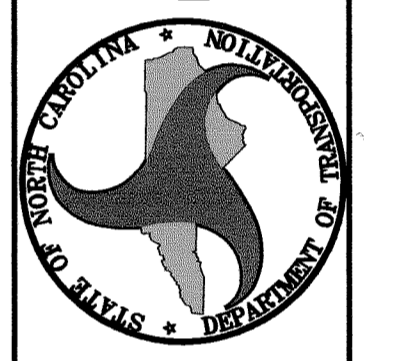

Washington County US-64
Rest Area/ Visitor Center
1248 US-64 EAST.
PLYMOUTH, NC 27962

PROJECT:

TIP PROJ. NO.	K-5000
WBS NO.	41532.3.1
CONTRACT ID NO.	
FEDERAL ID NO.	NHS-0064(158)
REVISIONS NO.	DATE

DATE ISSUED: 10/09/12
DRAWN BY:
CHECKED BY:
SHEET NO.
S1
1 OF 4

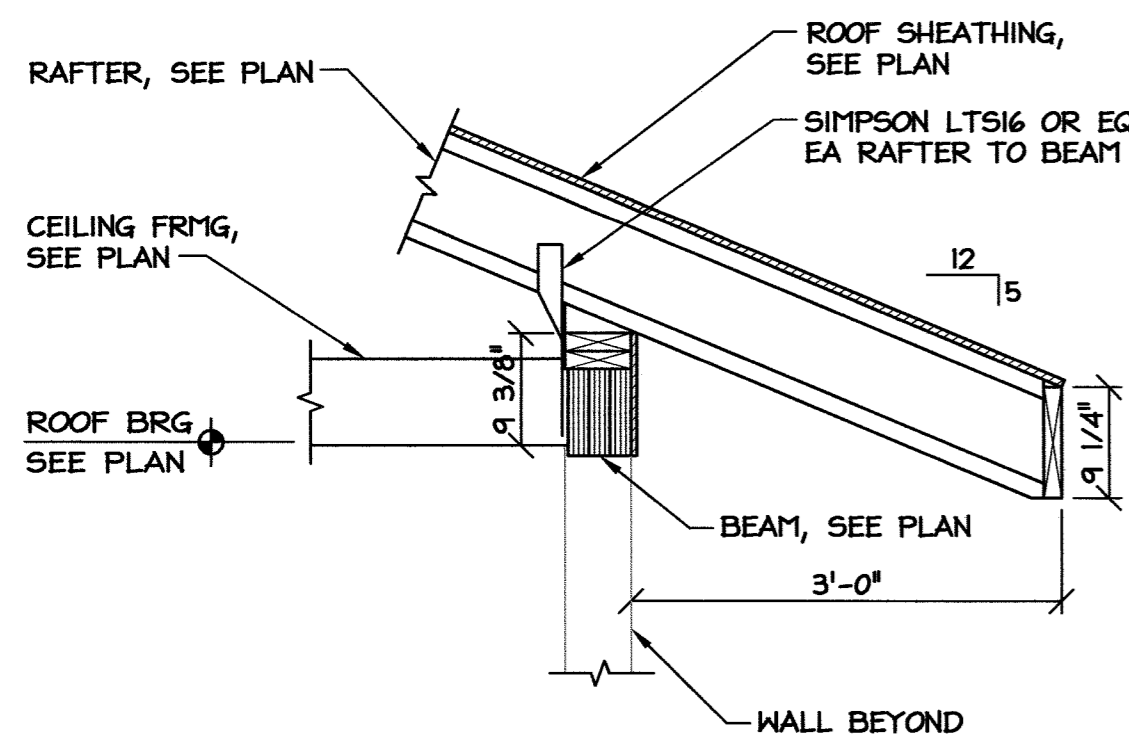

SEE TYP RAFTER BRG DETAIL FOR ITEMS NOT NOTED SEE ARCH FOR FASCIA & SOFFIT FRAMING

7 RAFTER BEARING AT HIP
SCALE: 3/4" = 1'-0"

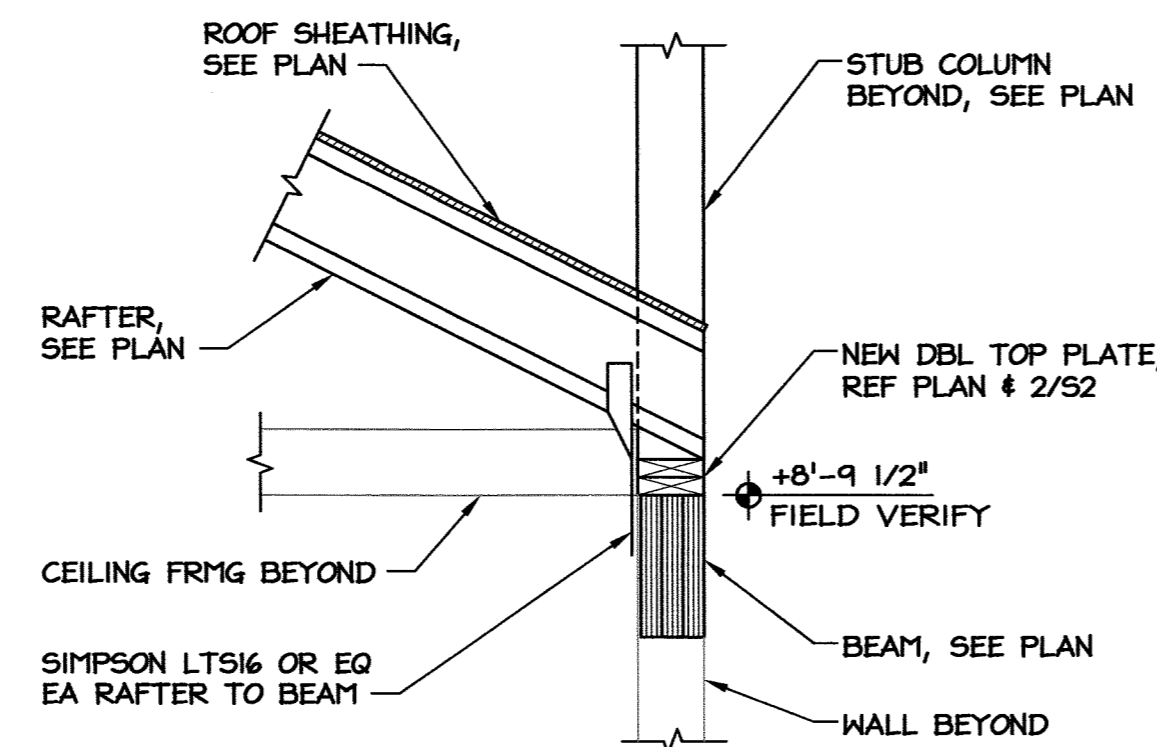

SEE TYP RAFTER BRG DETAIL FOR ITEMS NOT NOTED

4 INT RAFTER BRG
SCALE: 3/4" = 1'-0"

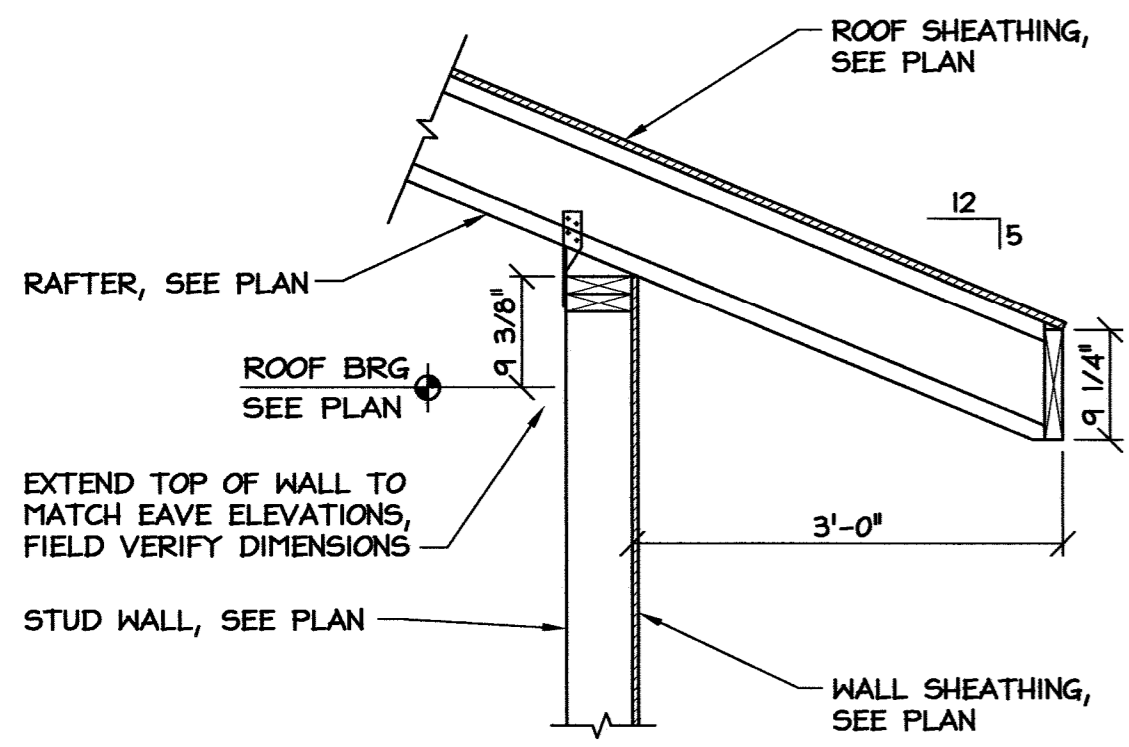

SEE TYP RAFTER BRG DETAIL FOR ITEMS NOT NOTED SEE ARCH FOR FASCIA & SOFFIT FRAMING

6 RAFTER BEARING AT HIP
SCALE: 3/4" = 1'-0"

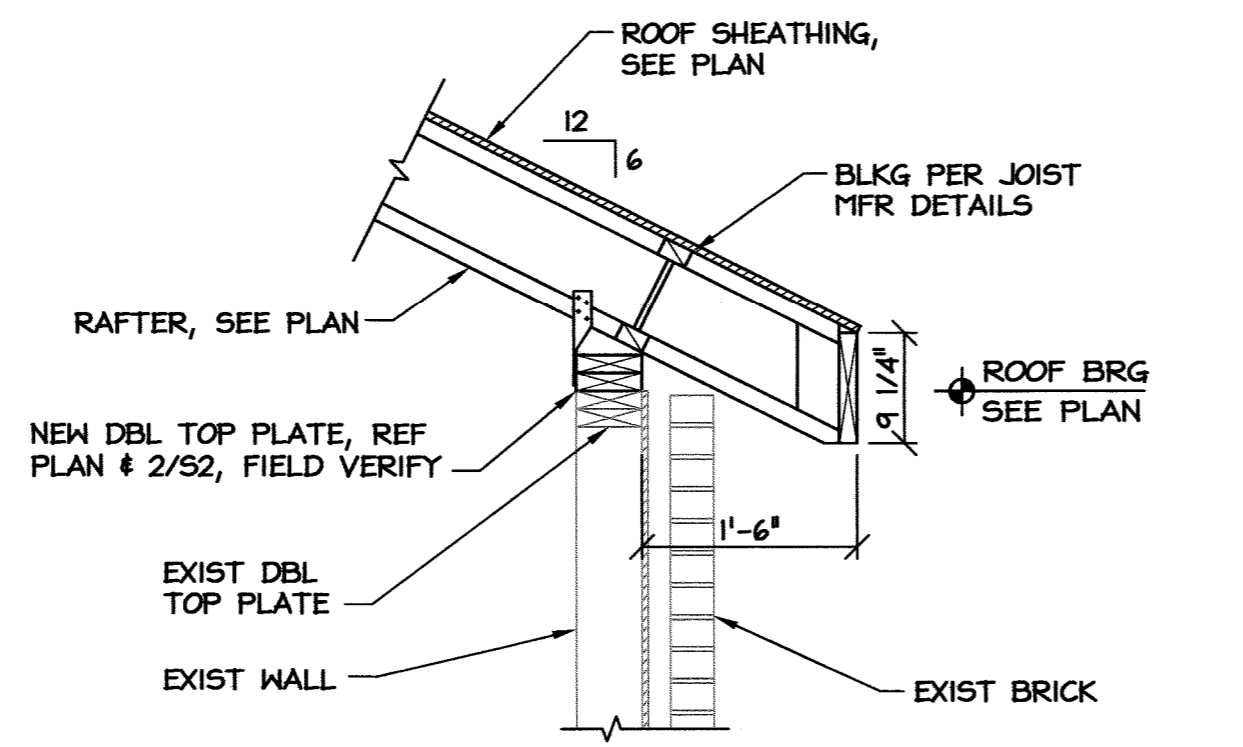

SEE TYP RAFTER BRG DETAIL FOR ITEMS NOT NOTED SEE ARCH FOR FASCIA & SOFFIT FRAMING

3 RAFTER BRG AT EXIST WALL
SCALE: 3/4" = 1'-0"

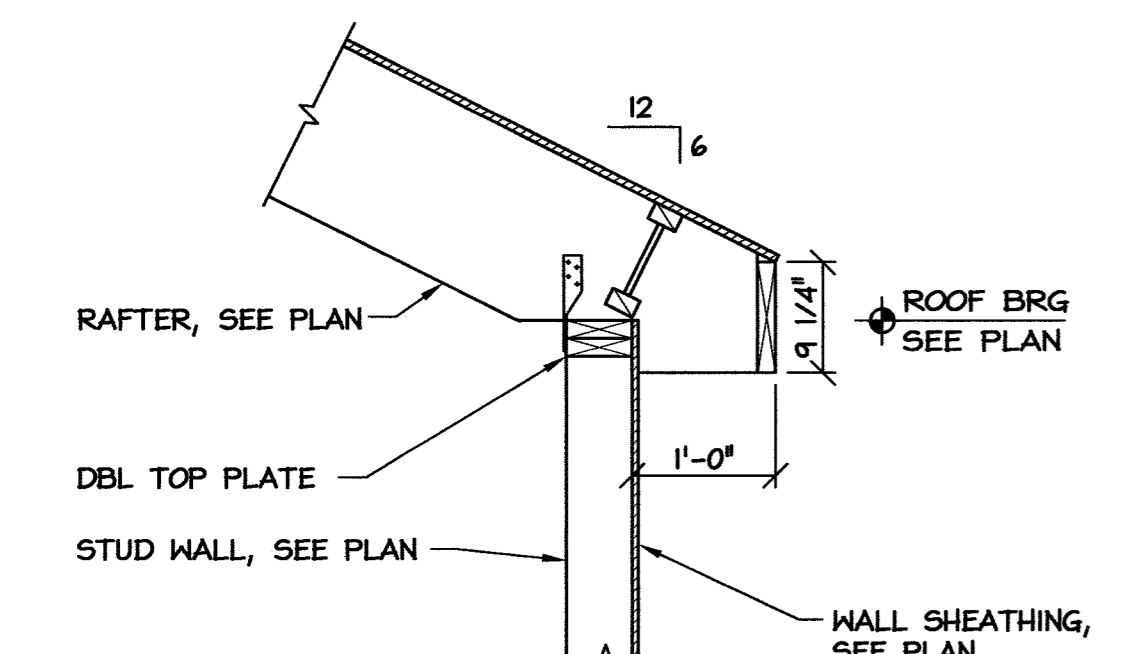

SEE TYP RAFTER BRG DETAIL FOR ITEMS NOT NOTED SEE ARCH FOR FASCIA & SOFFIT FRAMING

5 EXPOSED RAFTER BEARING
SCALE: 3/4" = 1'-0"

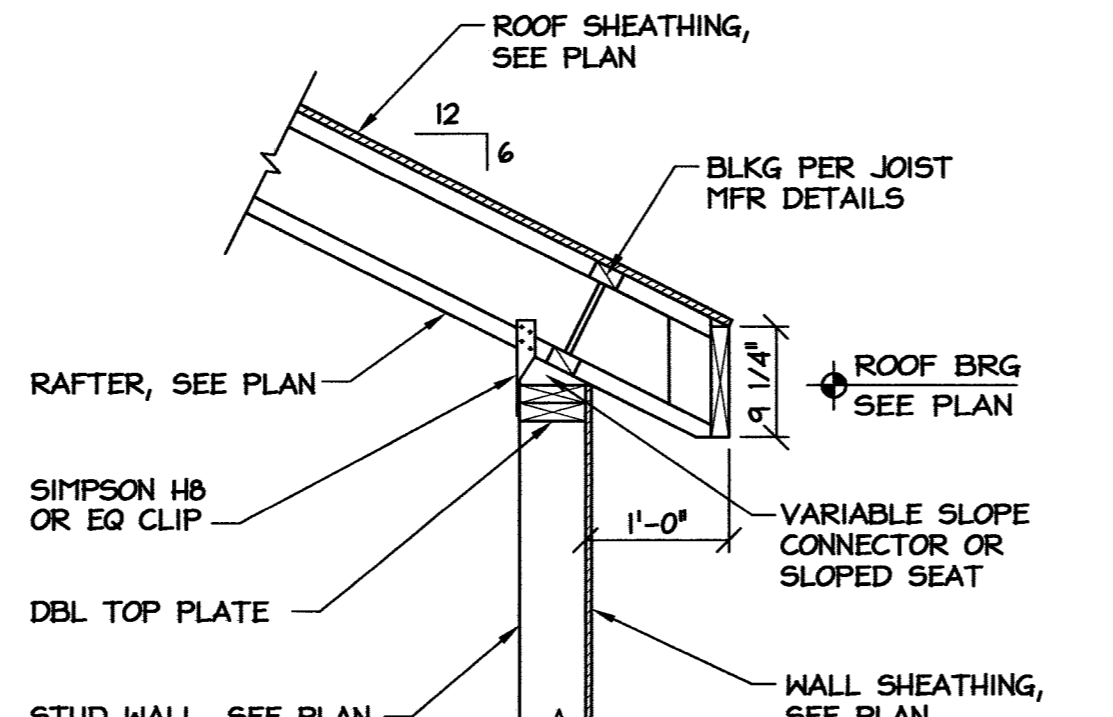

SEE ARCH FOR FASCIA & SOFFIT FRAMING

2 TYP RAFTER BEARING
SCALE: 3/4" = 1'-0"

NOTES:

1. FRAME WALLS W/ 2X6 @ 16, UON ON PLANS. GABLE WALL STUDS SHALL BE FULL HEIGHT (BALLOON FRAMED), UON.
2. MAXIMUM NOTCH OR HOLE SIZE SHALL NOT EXCEED 1/4 DEPTH OF WALL STUD W/OUT ENGINEER APPROVAL.
3. WALL SHEATHING SHALL BE 5/8 OSB OR PLYWOOD, W/ 24/16 SPAN RATING, EXPOSURE 1. ATTACH W/ 8D NAILS @ 6" OC ALONG ALL PANEL EDGES & 8" OC OTHERWISE.
4. RAFTERS ARE 9-1/2" WOOD 1-JOISTS @ 24" OC, UON.
5. INSTALL 1-JOIST FRAMING, INCLUDING BRIDGING & BRACING, IN ACCORDANCE W/ JOIST MFR REQUIREMENTS.
6. ELEVATIONS SHOWN ON STRUCTURAL DRAWINGS ARE ABOVE FIRST FINISH FLOOR, REF ELEVATION = +0'-0".
7. TOP OF NEW WALLS TO MATCH EXIST WALL ELEV = +8'-9 1/2" AFF, FIELD VERIFY.

8. FRAMING ELEVATIONS ARE BASED ON EXISTING WALL HEIGHT & SEPARATION. FIELD VERIFY & ADJUST ELEVATIONS AS REQUIRED.
9. ROOF SHEATHING SHALL BE 5/8 OSB OR PLYWOOD, W/ 32/16 SPAN RATING, EXPOSURE 1. ATTACH W/ 8D NAILS @ 6" OC ALONG ALL PANEL EDGES & 8" OC OTHERWISE.
10. SEE HEADER SCHEDULE FOR MISC. HEADERS NOT SPECIFIED ON PLANS. SEE ARCH FOR DOOR & WINDOW OPENINGS. SEE MECH FOR EQUIPMENT OPENINGS.
11. SUBMIT SHOP DRAWINGS FOR ALL CONCRETE & MASONRY FASTENERS & TRUSS TIE-DOWN CONNECTORS.
12. FRAME FLAT CEILINGS W/ 2X6 @ 16" OC, UON.

BEAM SCHEDULE	
MARK	SIZE
BM-1	(3) 2X10
BM-2	(3) 1-3/4" X 7-1/4" LVL
BM-3	(2) 1-3/4" X 9-1/2" LVL
BM-4	(3) 1-3/4" X 9-1/2" LVL
BM-5	(2) 1-3/4" X 11-7/8" LVL
BM-6	(3) 1-3/4" X 11-7/8" LVL
BM-7	(2) 1-3/4" X 14-0" LVL
BM-8	(2) 1-3/4" X 16-0" LVL

HEADER SCHEDULE		
STUD SIZE	OPENING	SIZE
2X4	UP TO 4'-0"	(2) 2X8
	4'-0" - 6'-8"	(2) 2X10
2X6	UP TO 4'-0"	(3) 2X8
	4'-0" - 6'-8"	(3) 2X10

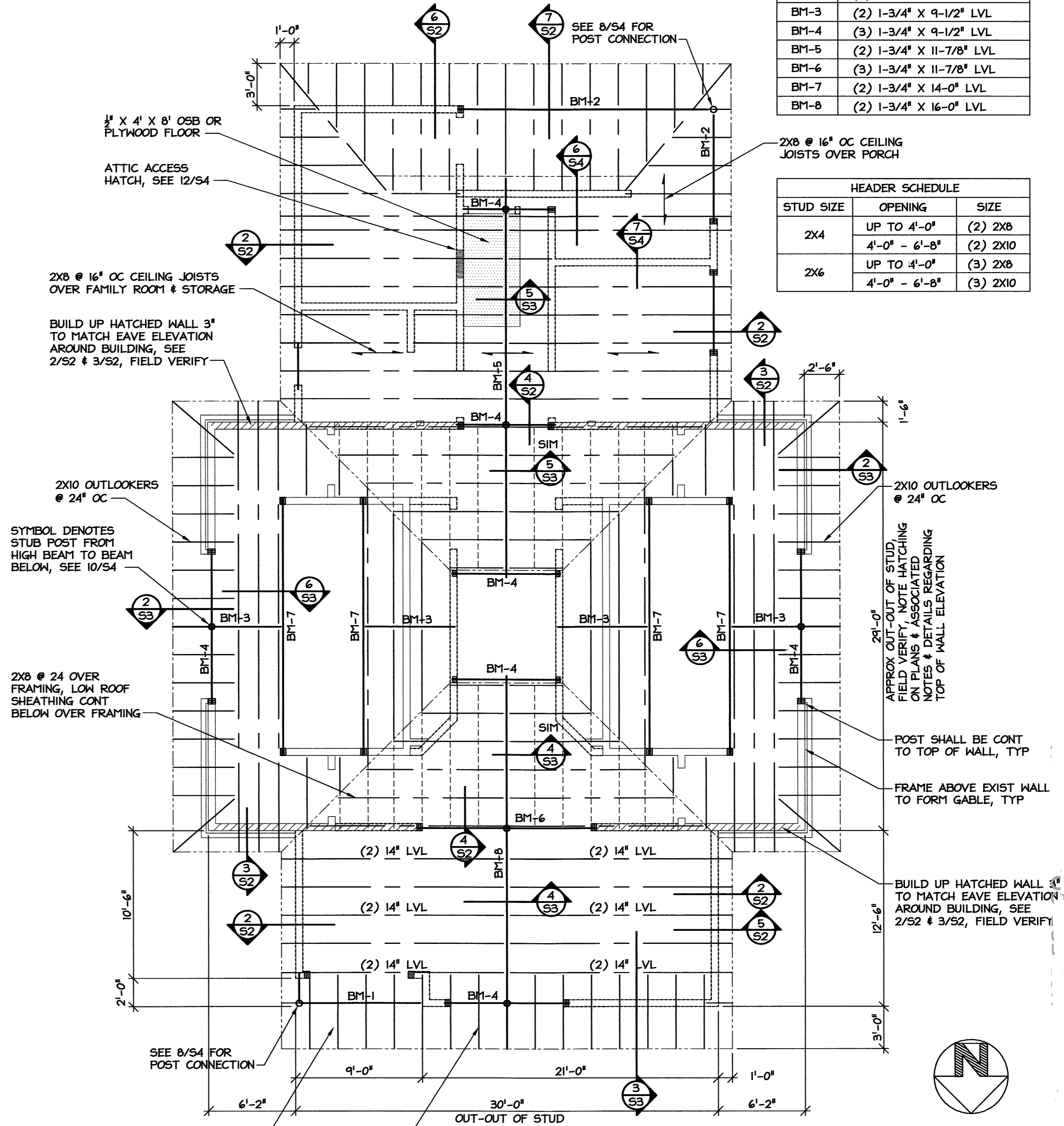

1 ROOF FRAMING PLAN
SCALE: 3/16" = 1'-0"

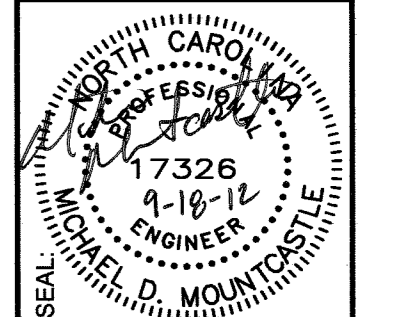

FACILITIES DESIGN ARCHITECTS & ENGINEERS
FACILITIES MANAGEMENT DIVISION, NCDOT
1 SOUTH WILMINGTON STREET
918/715-0400 FAX 918/715-0599
RALEIGH, NORTH CAROLINA 27601

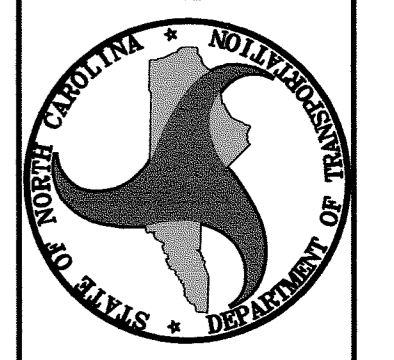

Washington County US-64
Rest Area/ Visitor Center
1248 US-64 EAST,
PLYMOUTH, NC 27962

PROJECT:

TIP PROJ. NO.	K-5000
WEBS NO.	41532.3.1
CONTRACT ID NO.	
FEDERAL ID NO.	NHS-0064(188)
REVISIONS	
NO.	DATE

DATE ISSUED: 10/09/12
DRAWN BY:
CHECKED BY:
SHEET NO.

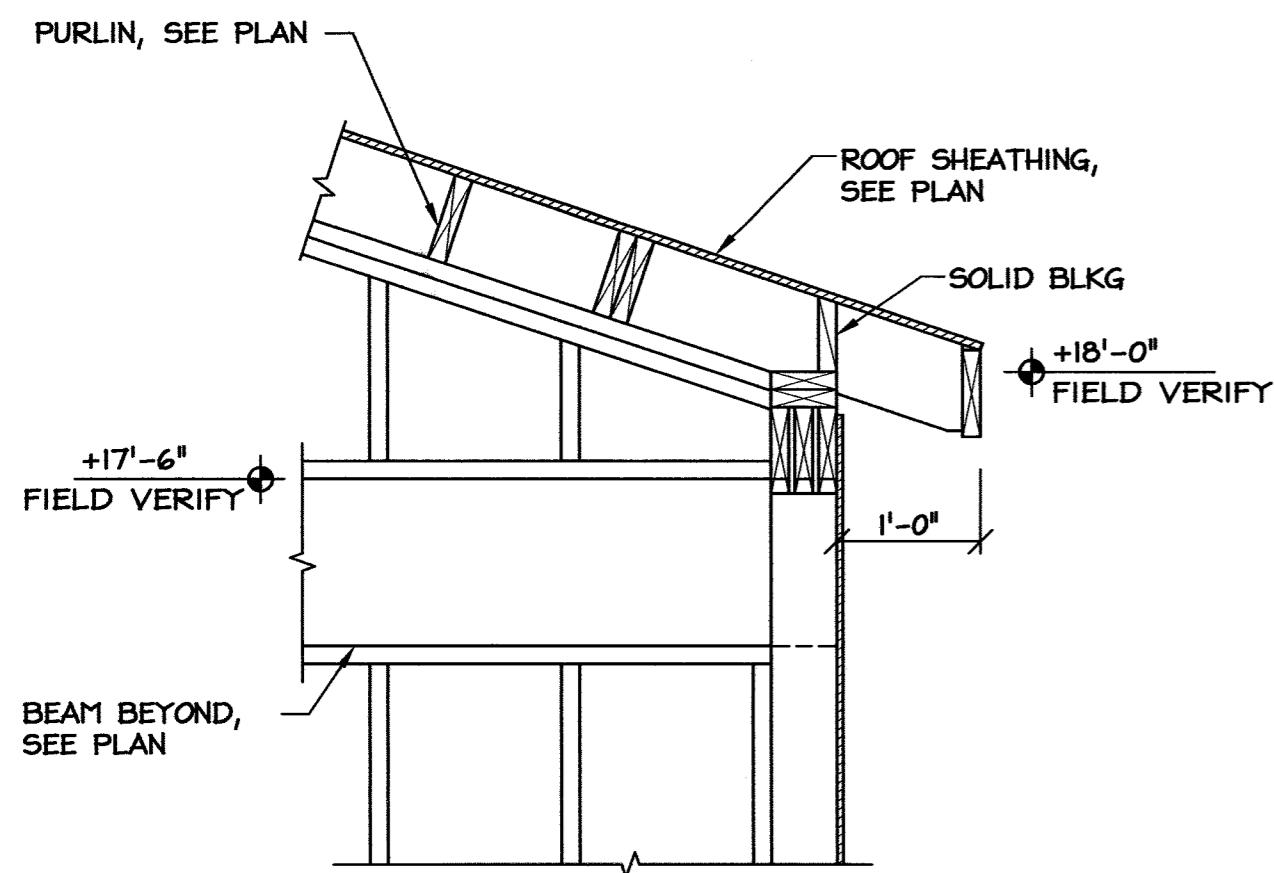

7 EAVE DETAIL AT DORMER
SCALE: 3/4" = 1'-0"

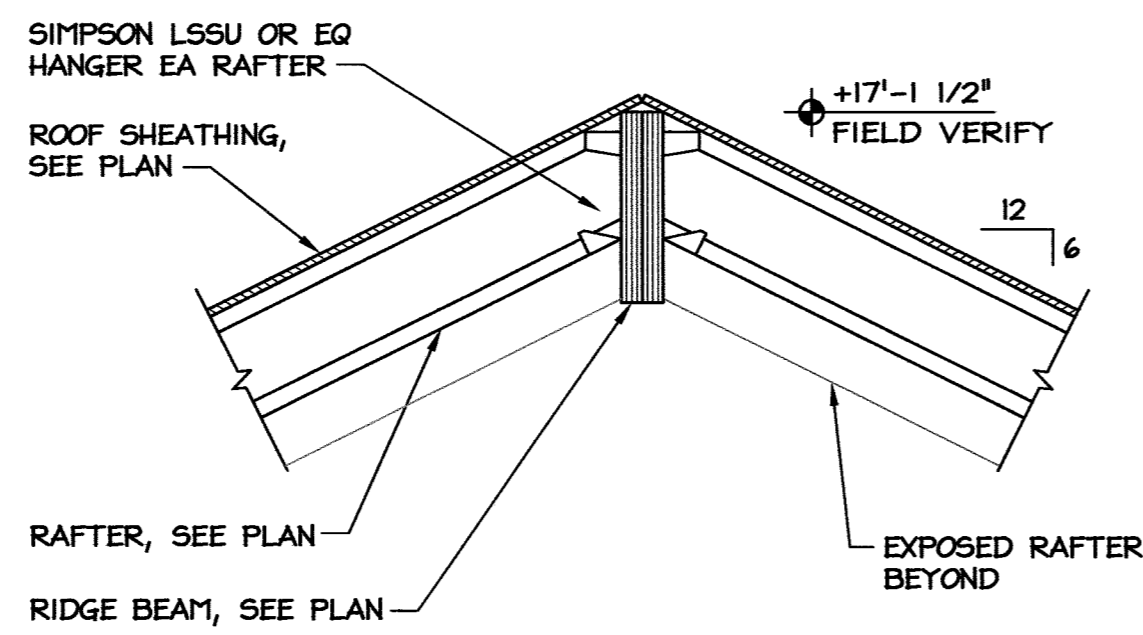

4 RAFTER BEARING AT RIDGE
SCALE: 3/4" = 1'-0"

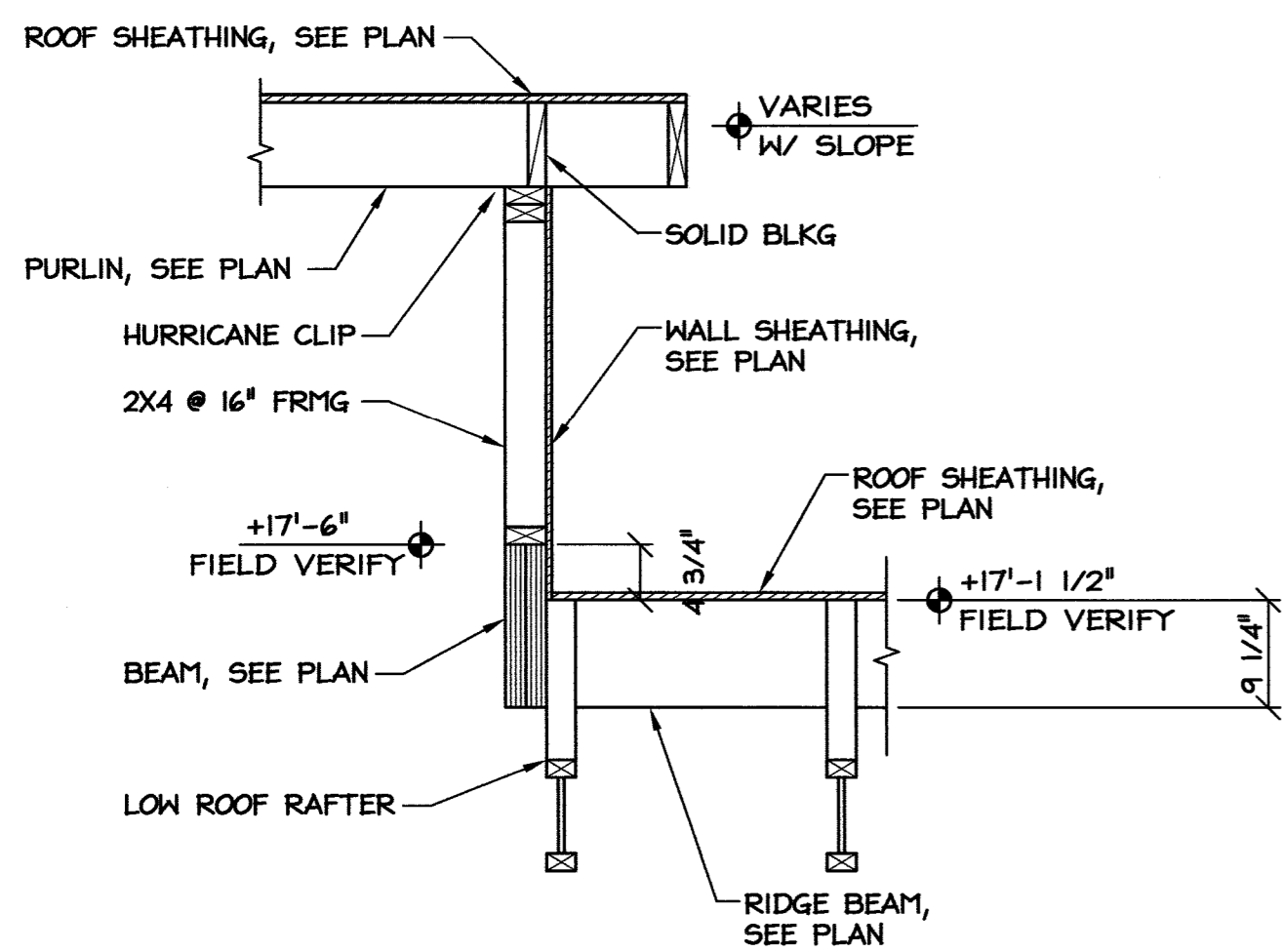

6 RIDGE BM CONN AT DORMER
SCALE: 3/4" = 1'-0"

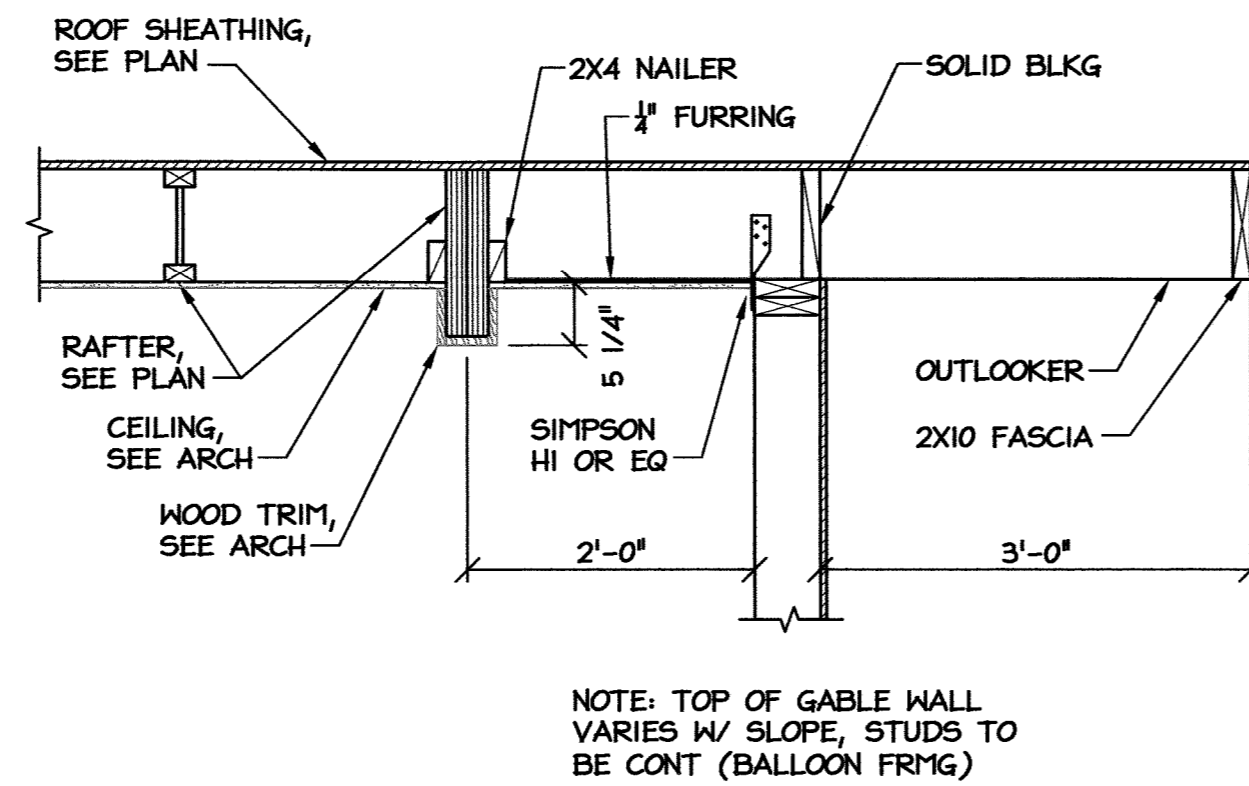

3 GABLE DETAIL AT LOBBY
SCALE: 3/4" = 1'-0"

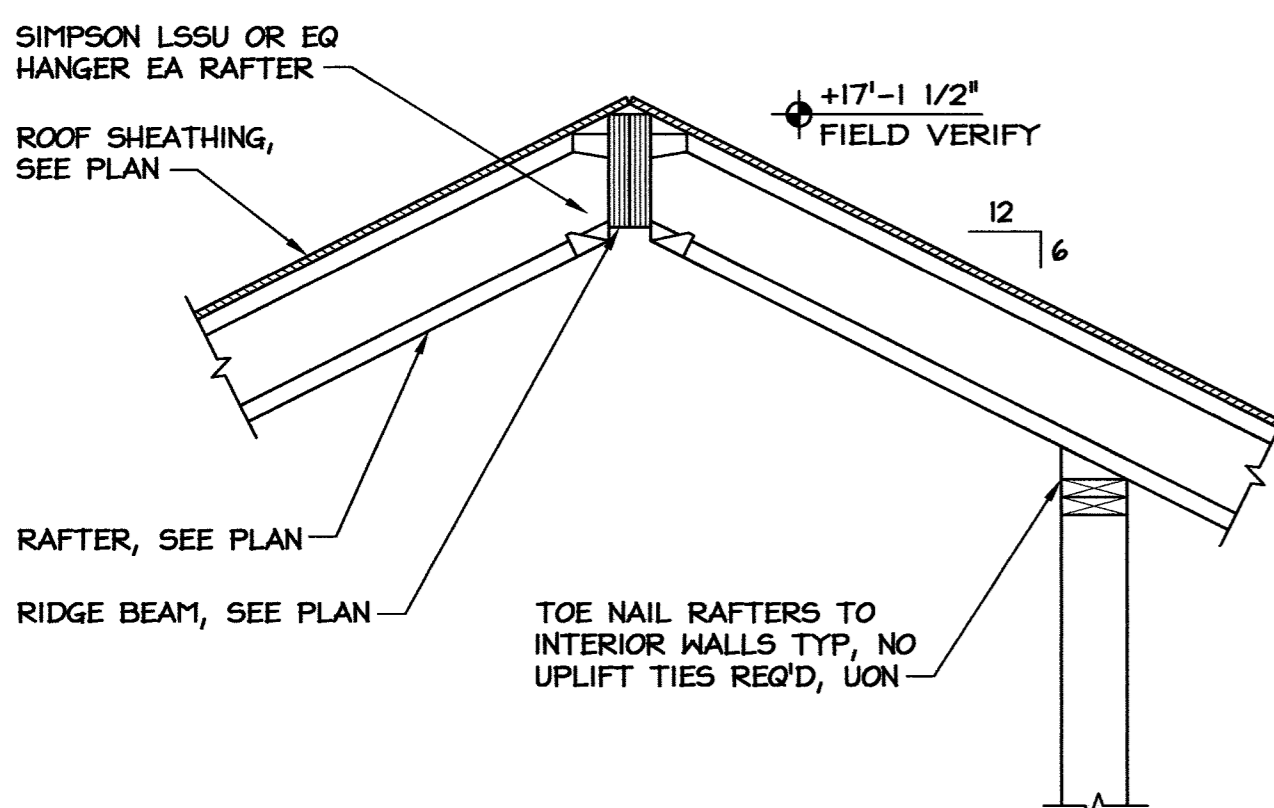

5 RAFTER BEARING AT RIDGE
SCALE: 3/4" = 1'-0"

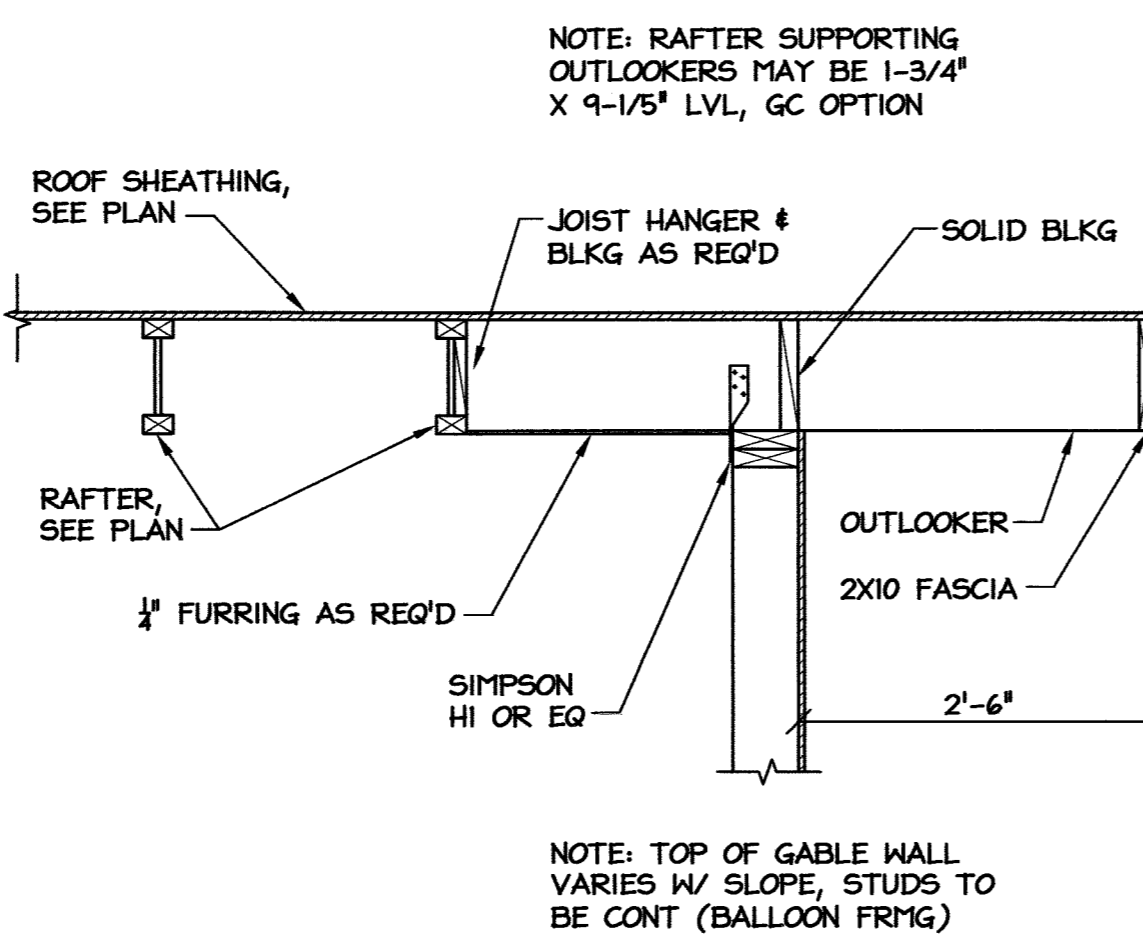

2 GABLE AT RESTROOMS
SCALE: 3/4" = 1'-0"

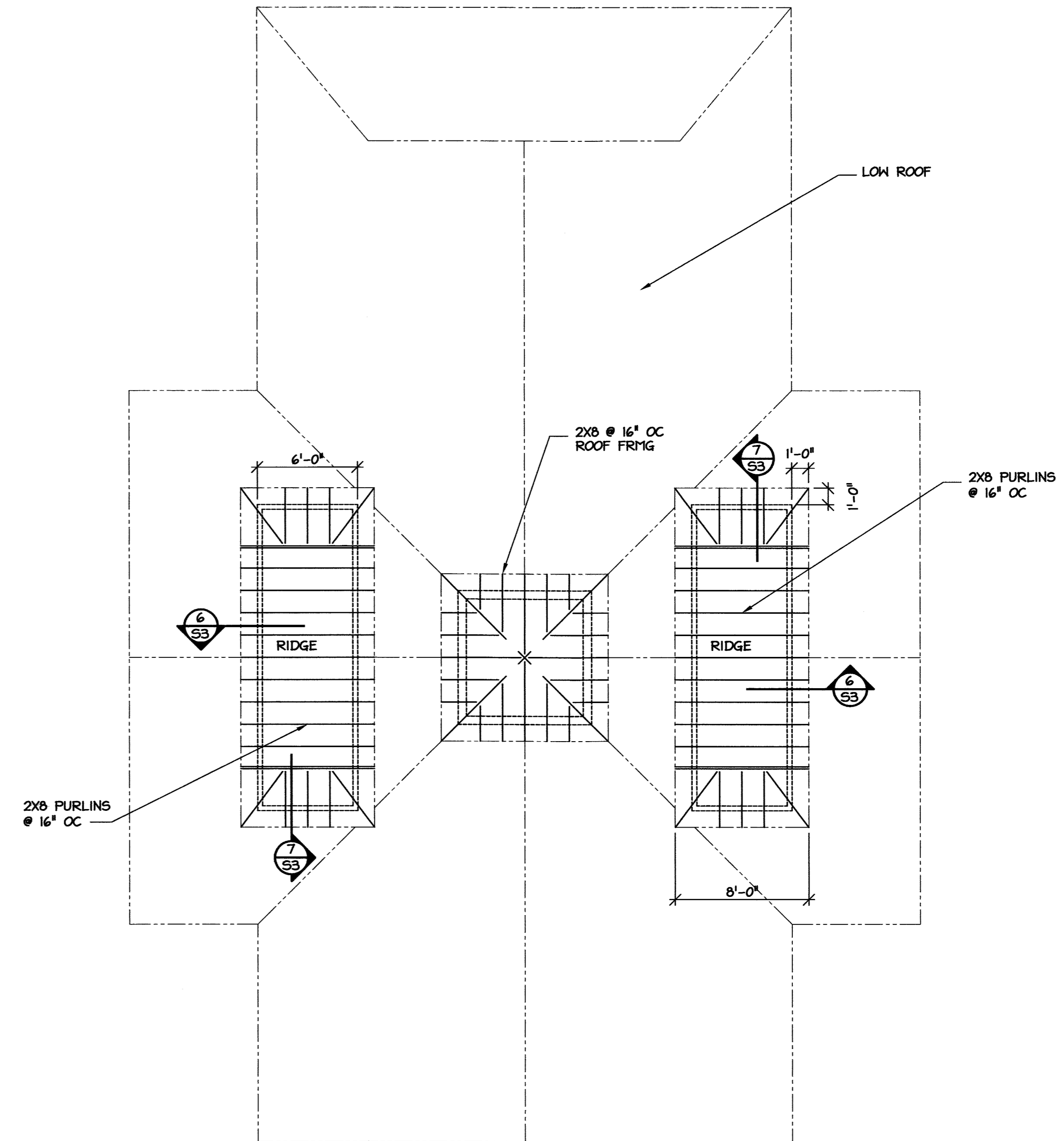

1 HIGH ROOF FRAMING PLAN
SCALE: 3/16" = 1'-0"

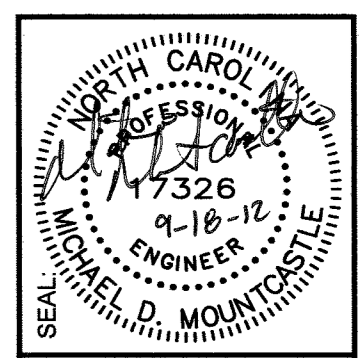

FACILITIES DESIGN ARCHITECTS & ENGINEERS
FACILITIES MANAGEMENT DIVISION, NCDOT
1 SOUTH WILMINGTON STREET
919/715-0400 FAX: 919/715-0399
RALEIGH, NORTH CAROLINA 27601

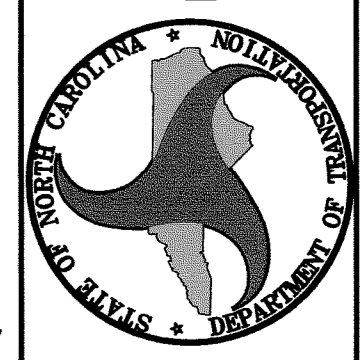

PROJECT: Washington County US-64 Rest Area/ Visitor Center
1248 US-64 EAST, PLYMOUTH, NC 27962

TIP PROJ. NO.	K-5000
WBS NO.	41532.3.1
CONTRACT ID NO.	
FEDERAL ID NO.	NHS-0064(158)
REVISIONS	DATE
NO.	

DATE ISSUED: 10/09/12
DRAWN BY:
CHECKED BY:

SHEET NO. **S3**
3 OF 4

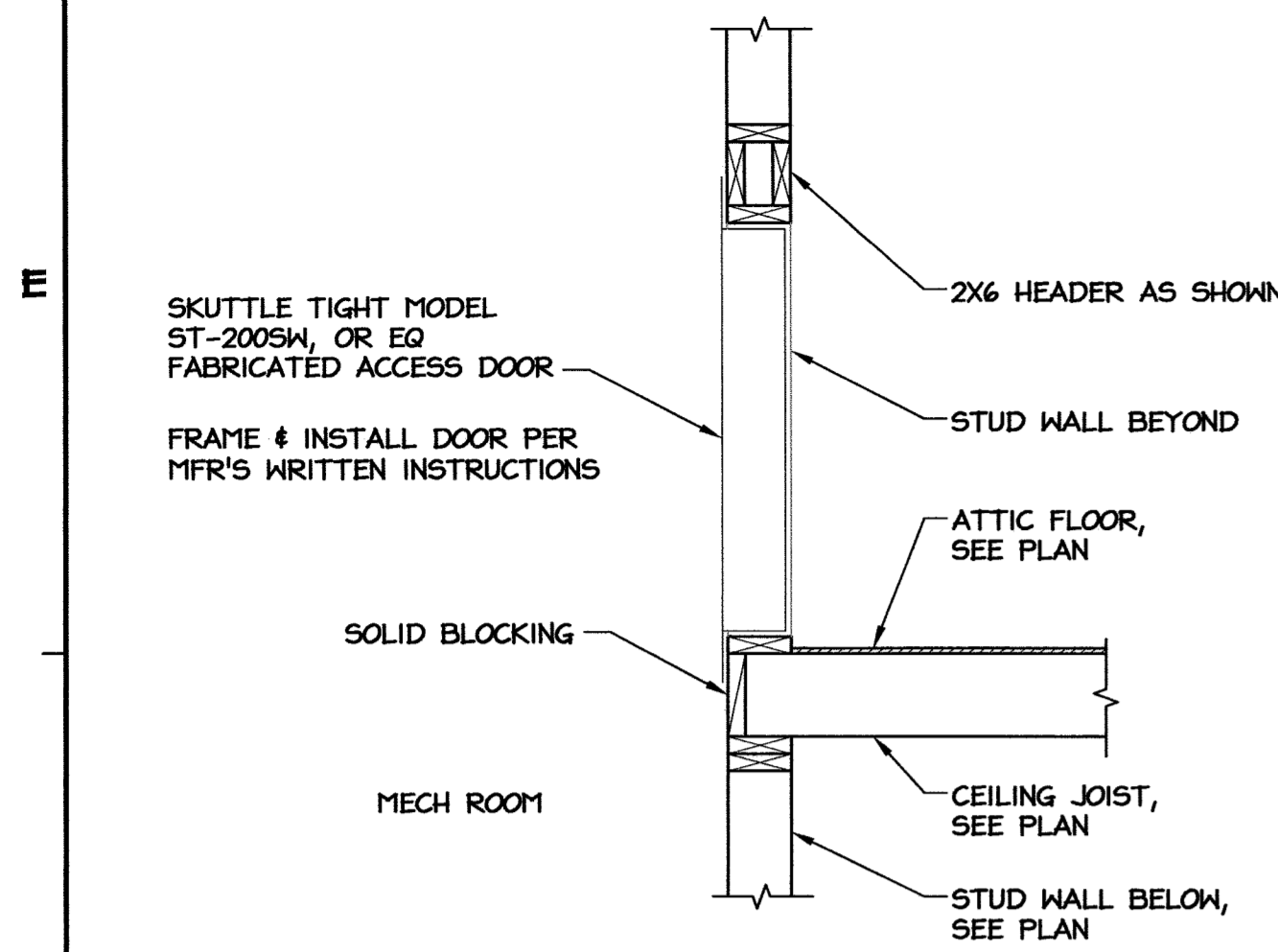

12 ATTIC ACCESS HATCH
S4 SCALE: 3/4" = 1'-0"

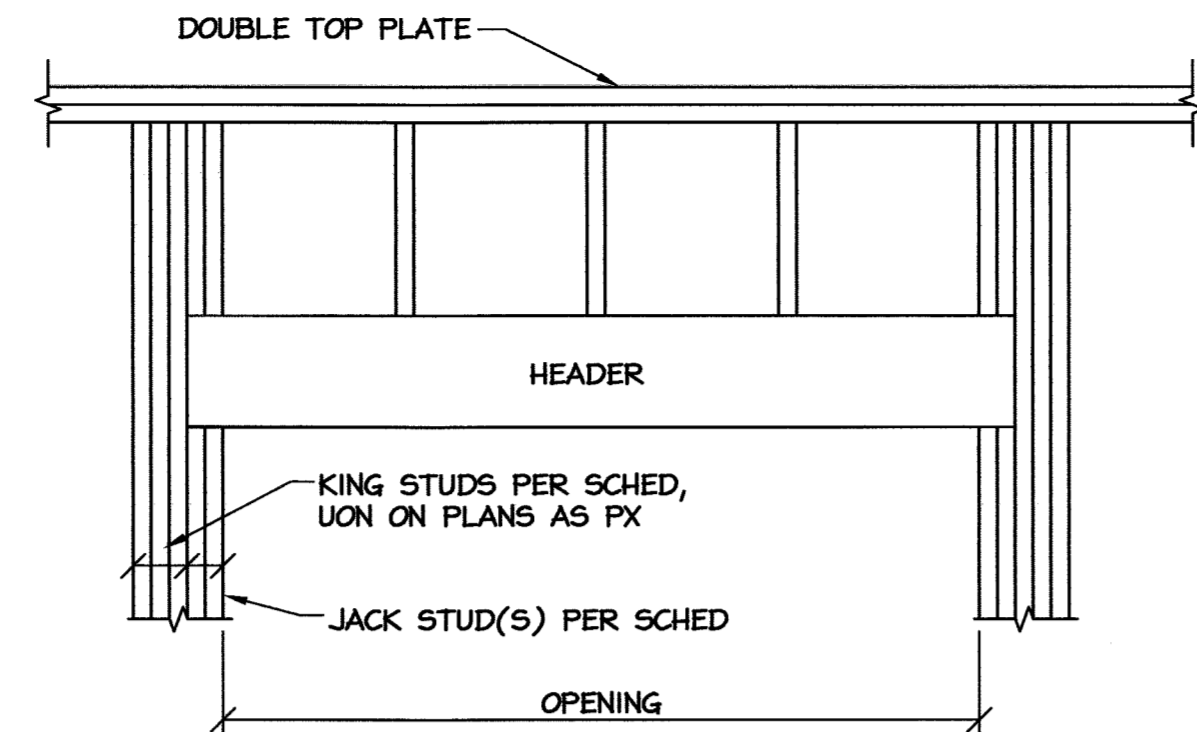

OPENING SIZE	JACK STUD(S)	KING STUDS
UP TO 4'-0"	(1) EA SIDE	(2) EA SIDE
4'-0" TO 8'-0"	(2) EA SIDE	(3) EA SIDE

9 TYP FRAMING AT OPENING
S4 SCALE: 3/4" = 1'-0"

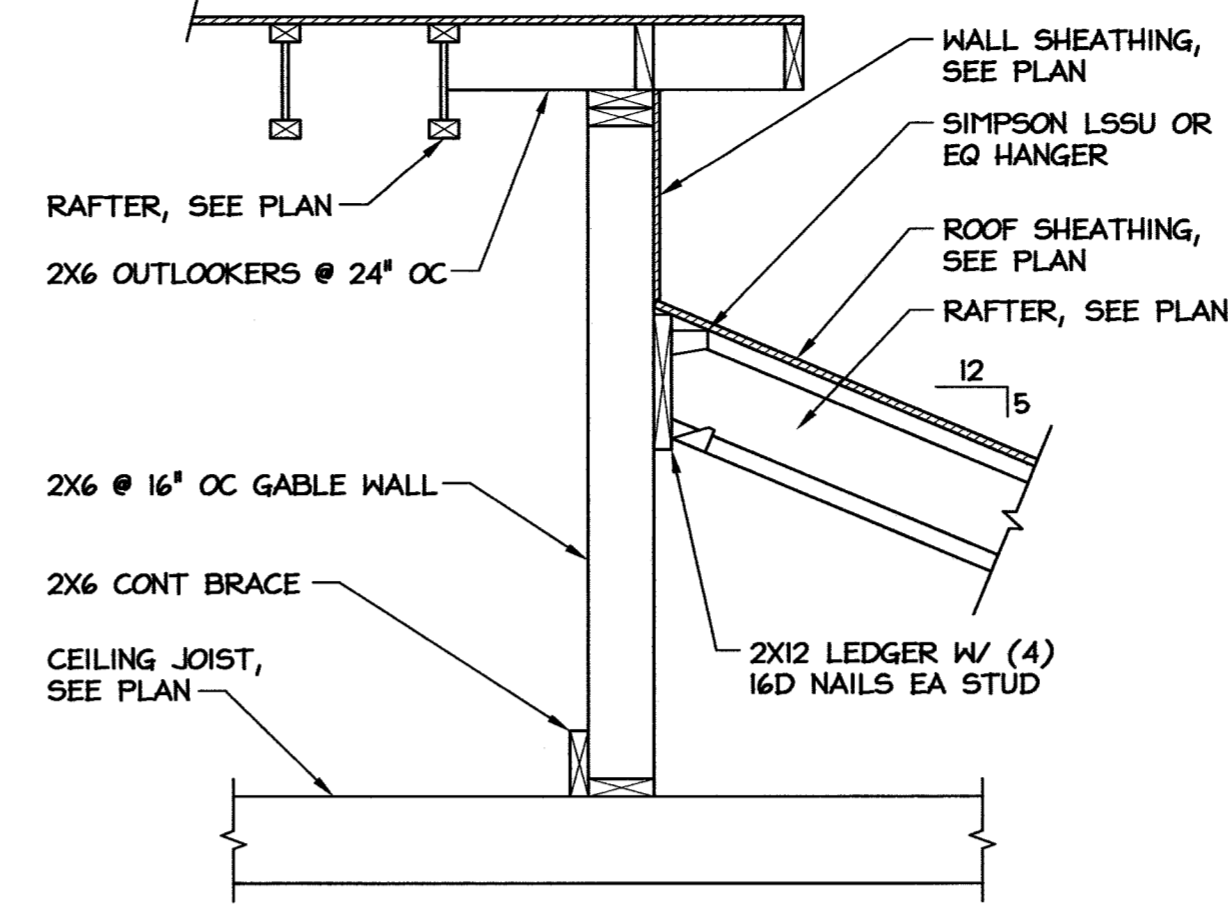

6 GABLE AT PORCH
S4 SCALE: 3/4" = 1'-0"

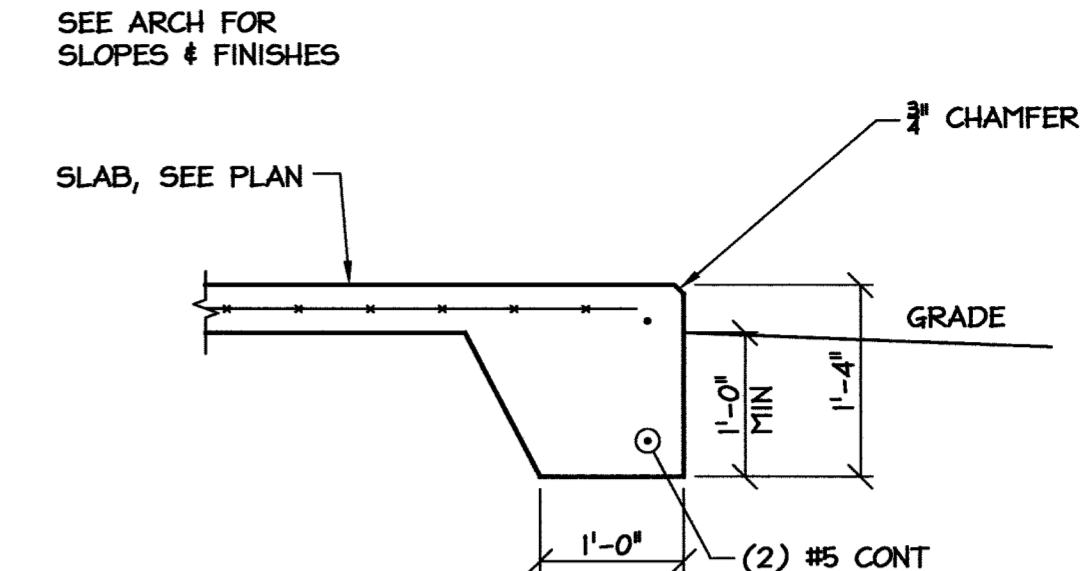

3 PORCH SLAB EDGE
S4 SCALE: 3/4" = 1'-0"

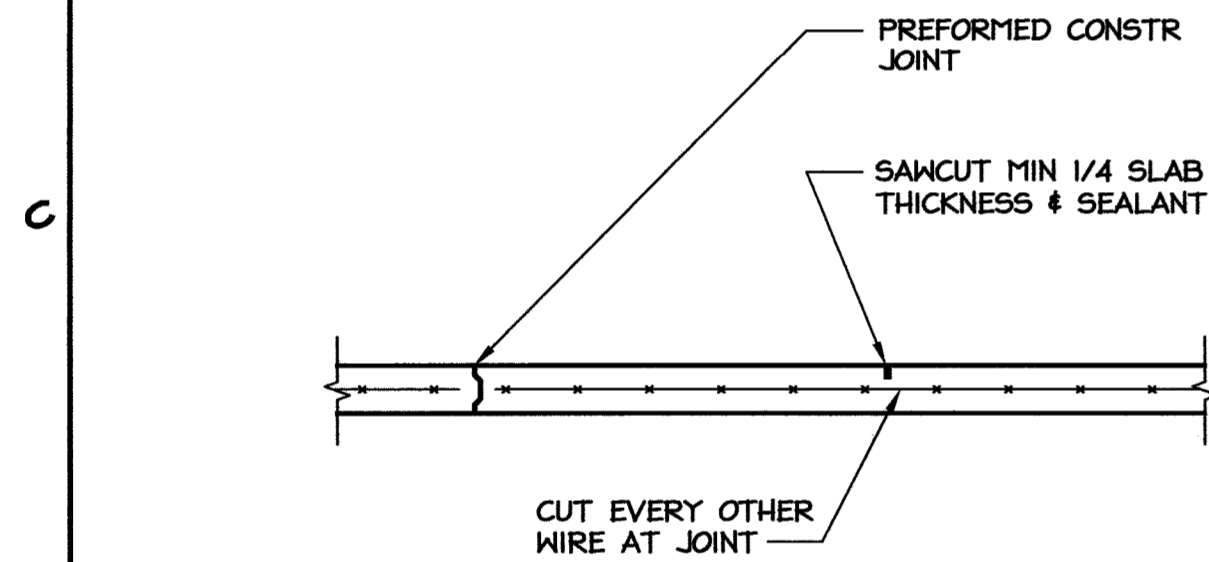

11 SLAB CONTROL JOINTS
S4 SCALE: 3/4" = 1'-0"

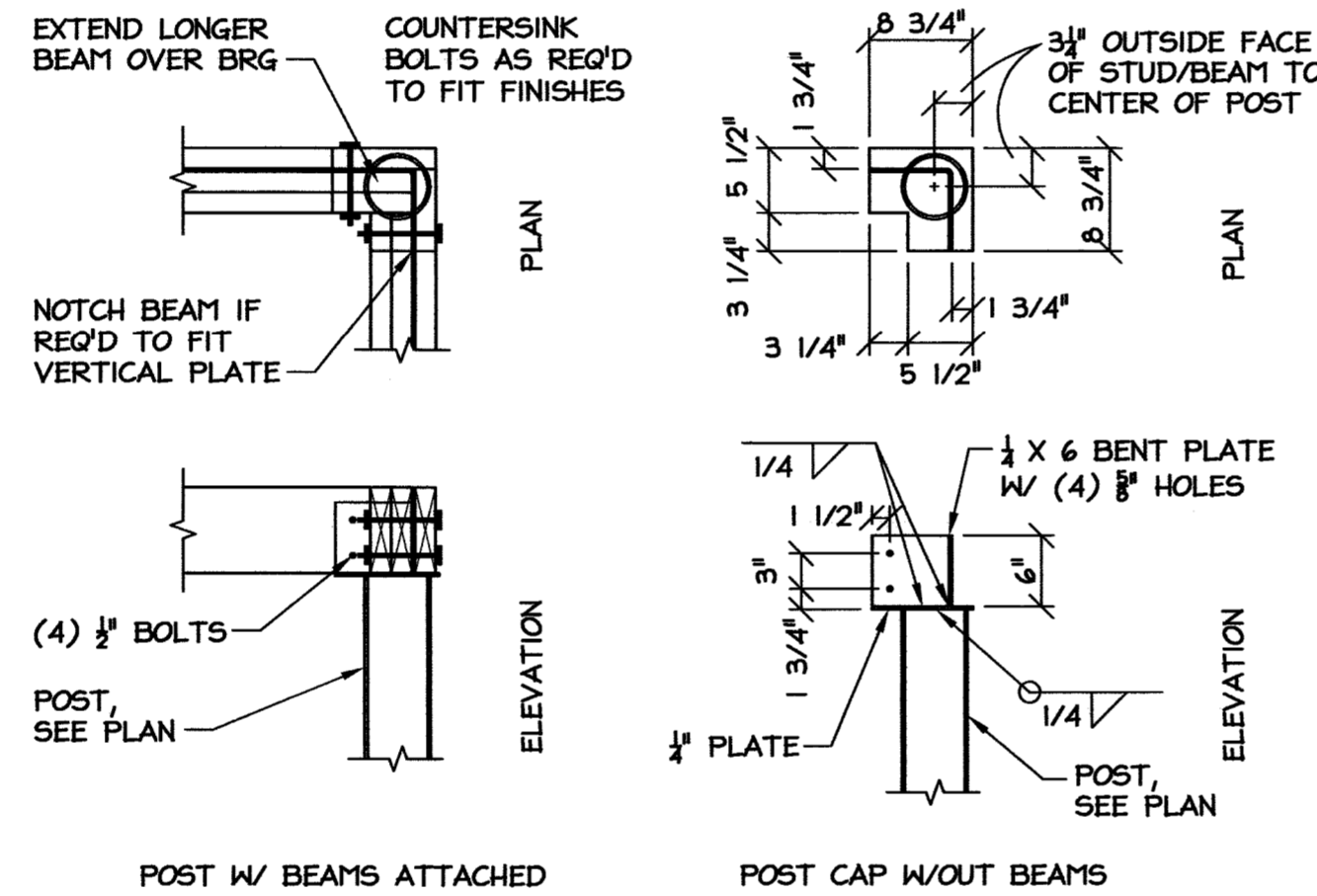

8 BEAM BRG AT STEEL POST
S4 SCALE: 3/4" = 1'-0"

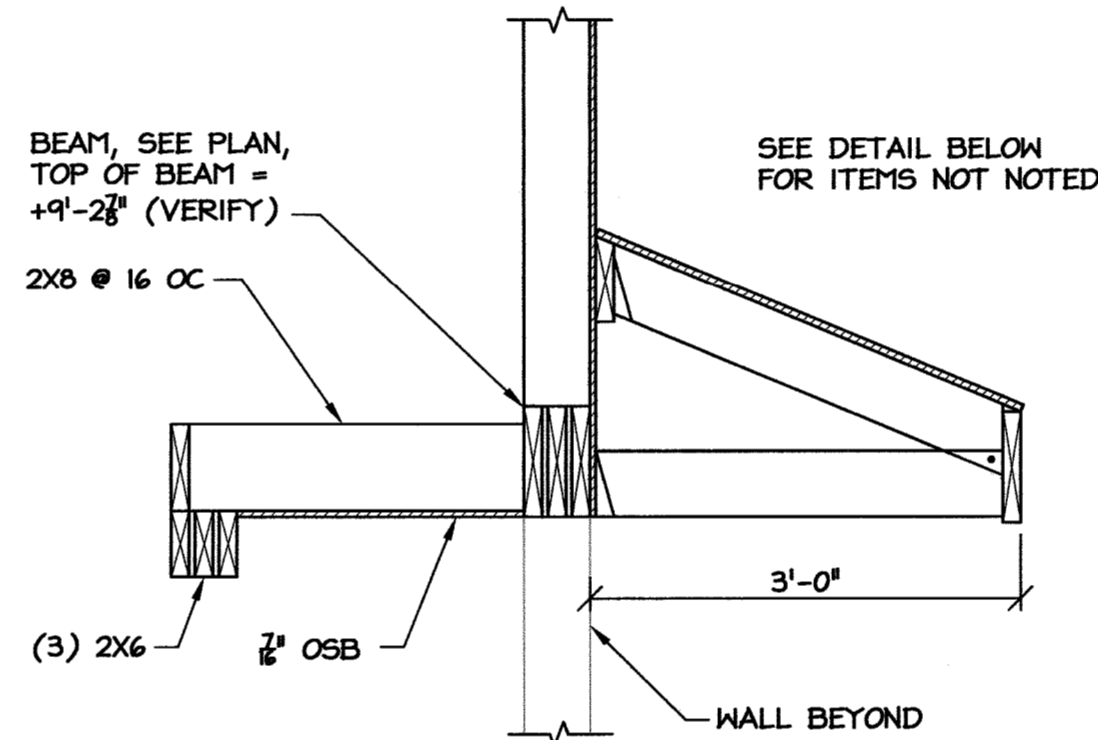

5 EYEBROW AT ENTRY
S4 SCALE: 3/4" = 1'-0"

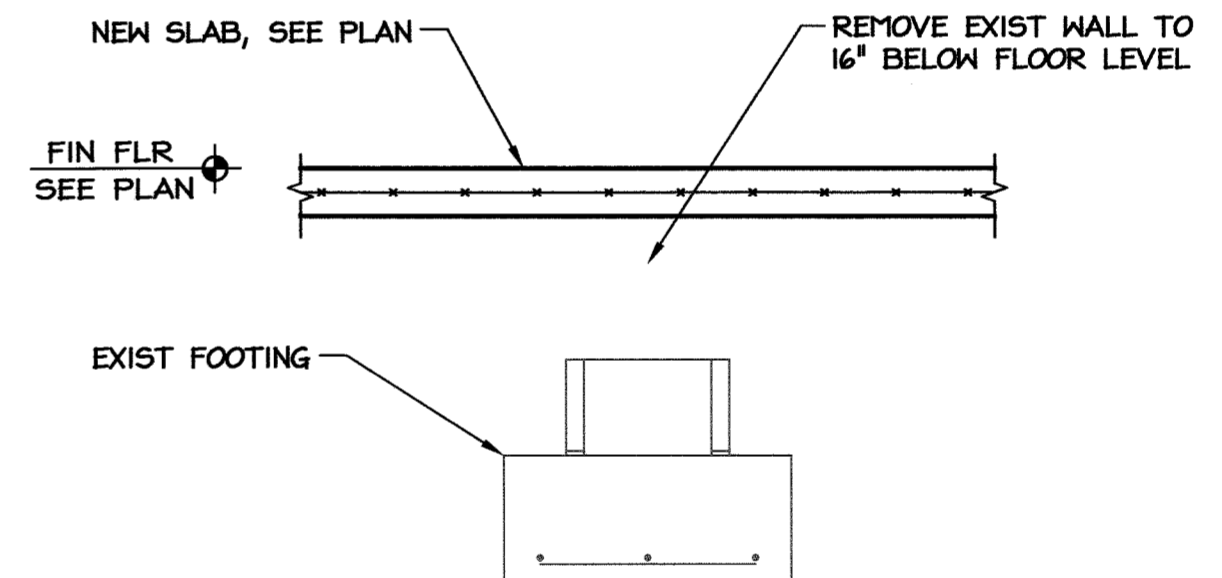

2 EXISTING STRIP FOOTING
S4 SCALE: 3/4" = 1'-0"

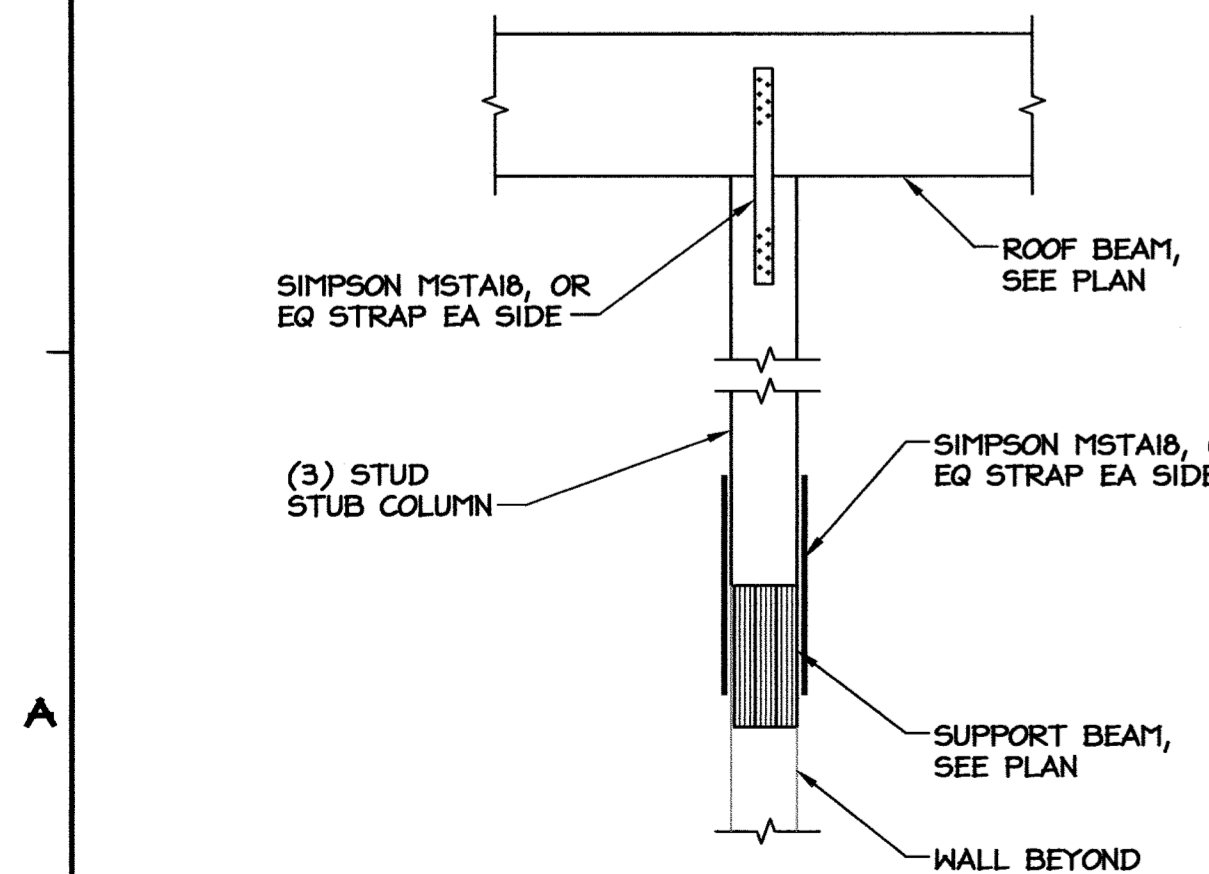

10 TIE DOWN AT STUB COLUMNS
S4 SCALE: 3/4" = 1'-0"

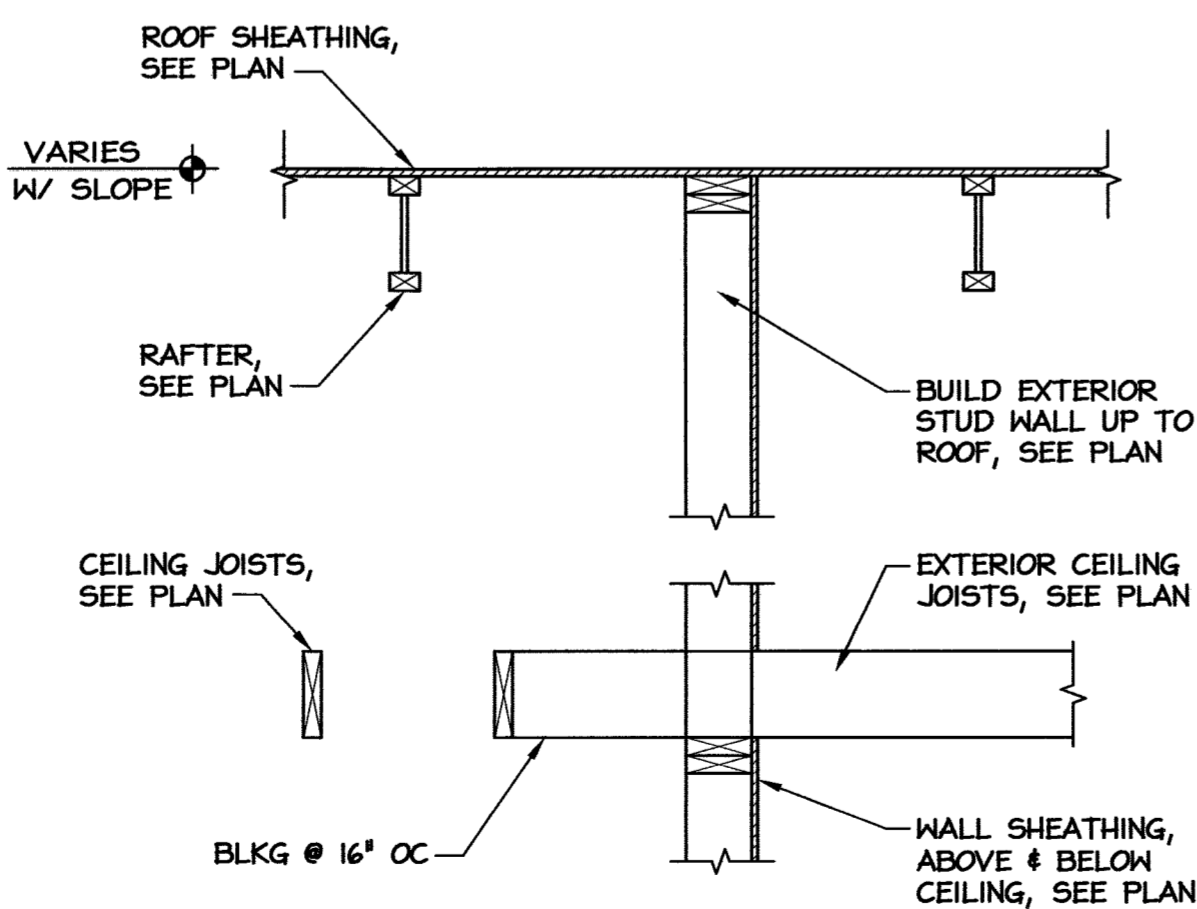

7 GABLE AT VENDING
S4 SCALE: 3/4" = 1'-0"

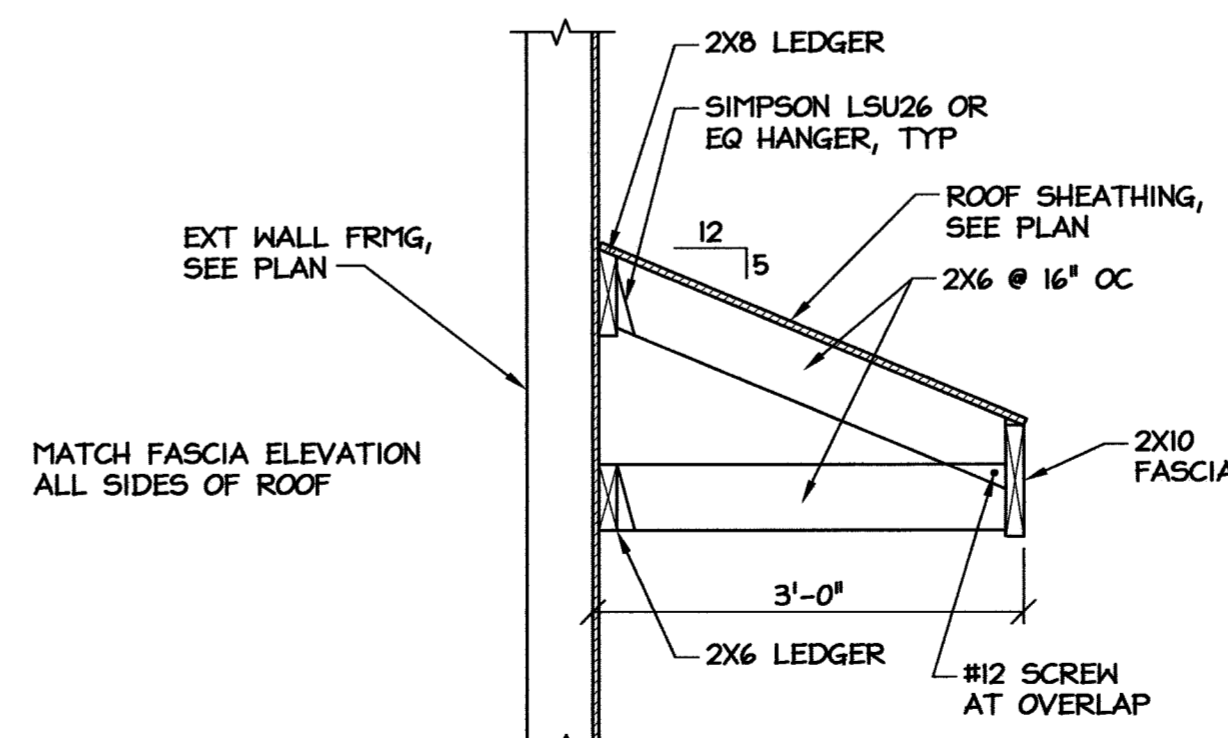

4 EYEBROW AT LOBBY
S4 SCALE: 3/4" = 1'-0"

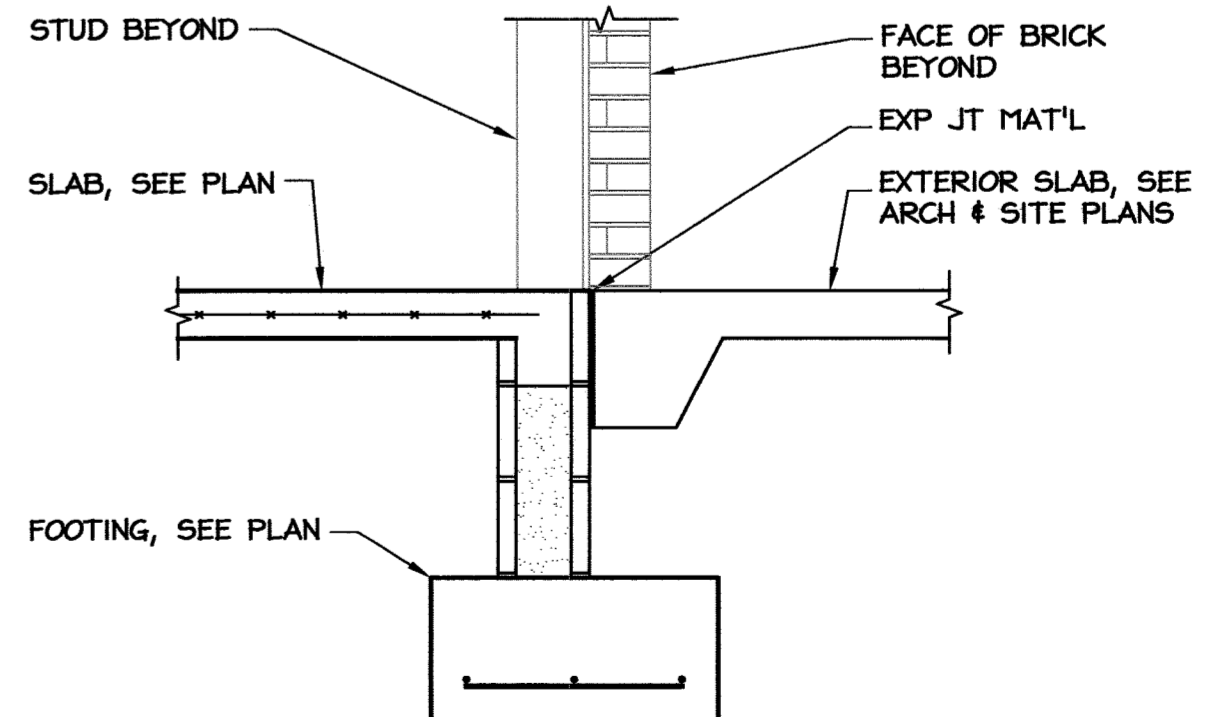

1 SLAB EDGE AT DOOR
S4 SCALE: 3/4" = 1'-0"

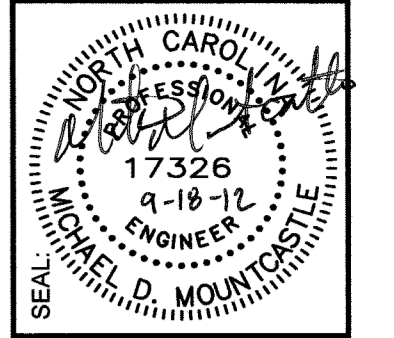

FACILITIES DESIGN
ARCHITECTS & ENGINEERS
 FACILITIES MANAGEMENT DIVISION, NCDOT
 1 SOUTH WILMINGTON STREET
 RALEIGH, NORTH CAROLINA 27601
 919.715.0400 FAX: 919.715.0399

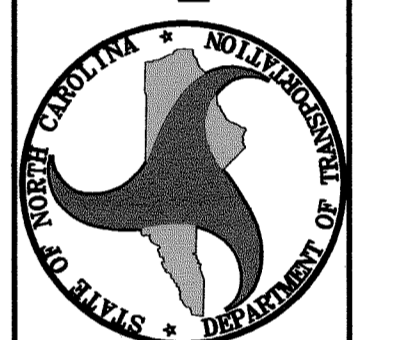

Washington County US-64
 Rest Area/ Visitor Center
 1248 US-64 EAST.
 PLYMOUTH, NC 27962

PROJECT:

TIP PROJ. NO.	K-5000
WBS NO.	41532.3.1
CONTRACT ID NO.	
FEDERAL ID NO.	NHS-0064(158)
REVISIONS NO.	DATE
DATE ISSUED:	10/09/12
DRAWN BY:	
CHECKED BY:	
SHEET NO.	

S4
4 OF 4

PLUMBING FIXTURE SCHEDULE *

MARK	DESCRIPTION	ALTERNATE MANUFACTURER/MODEL	ALTERNATE MANUFACTURER/MODEL
WC/ WCHC	WATER CLOSET AMERICAN STANDARD "AFWALL FLOWISE 1.28 GPF" #3353.128, ELONGATED BOWL, VITREOUS CHINA, AND 1 1/2" BACK SPUD. WCHC TO BE ADA COMPLIANT. PROVIDE OPEN FRONT SEAT, AND SENSOR W/ MANUAL OVERRIDE FLUSH VALVE, EQUAL TO HYDROTEK H-8000C-CB-WB FLUSH VALVE W/ELEC. WALL BOX.	ZURN #Z5617 FIXTURE. ZURN #ZEMS6140AV FLUSH VALVE.	KOHLER KINGSTON #K-4329 FIXTURE. SLOAN REGAL OPTIMA MODEL 152-1.28ES-S VALVE.
WC-1	WATER CLOSET AMERICAN STANDARD "MADERA FLOWISE 1.28 GPF" #3461.128, ELONGATED BOWL, VITREOUS CHINA, AND 1 1/2" TOP SPUD. ADA COMPLIANT. PROVIDE OPEN FRONT SEAT, AND SENSOR W/ MANUAL OVERRIDE FLUSH VALVE EQUAL TO HYDROTEK H-8000C-CT-WB FLUSH VALVE.	ZURN #Z5665 FIXTURE. ZURN #ZEMS6000IS FLUSH VALVE.	KOHLER HIGHCREST #K-4302 FIXTURE. REGAL OPTIMA MODEL 153-1.28ES-S VALVE.
UR	WATER-LESS URINAL EXISTING TO BE RE-USED. REMOVE AND STORE FOR RE-USE.		
L1	LAVATORY (ACCESSIBLE, WALL HUNG) EXISTING TO BE RE-USED. REMOVE AND STORE FOR RE-USE. REMOVE EXISTING HANDS-FREE FAUCET AND STORE FOR RE-USE.		
L2	LAVATORY (ACCESSIBLE, WALL HUNG) AMERICAN STANDARD "LUCERNE" # 0355.012 WHITE WITH CONCEALED ARM CARRIER AND DRAIN ASSEMBLY (7723.018). ADA COMPLIANT. FURNISH WITH SLOAN EBF-85 BATTERY POWERED FAUCET. COORDINATE TRIM AND SINK FAUCET DRILLING FOR SINGLE HOLE OR AS REQUIRED PER OWNER.	KOHLER GREENWICH #K-2032 WITH CHICAGO SENSOR FAUCET #166.606.	ELJER MURRAY II #051-0244 WITH SPEAKMAN SENSOR FAUCET S-8700.
MS	MOP SINK FAUCET ACORN MODEL KFC CHROME PLATED SERVICE FAUCET WITH VACUUM BREAKER, INTEGRAL STOPS, ADJUSTABLE WALL BRACE, PAIL HOOK AND 3/4" HOSE THREAD ON SPOUT.	SPEAKMAN #MR-371 MOP SINK FAUCET.	CRANE #830-AA MOP SINK FAUCET.
CP	CIRCULATING PUMP BELL & GOSSET, SERIES NBF-22 IN-LINE CIRCULATOR PUMP, 1/12 HP, 115 VAC, FLA=0.8 1 Ph., 3/4" CONN., WITH A MAXIMUM OF 22 GPM AND 15' TDH. PUMP TO BE ALL BRONZE CONSTRUCTION, COORDINATE WITH ELEC. CONTRACTOR FOR POWER FEED. PROVIDE DISCONNECT SWITCH.	TACO MODEL #110.	ARMSTRONG MODEL #S-25.
EWC	HIGH/LOW ELECTRIC WATER COOLER OASIS DUAL LEVEL ELECTRIC WATER COOLER. MODEL # P8ACSL, ADA COMPLIANT. PIPE TO SINGLE DRAIN AND SUPPLY LINE.	HALSEY TAYLOR #HACBBL-Q.	ELKAY MODEL #EZSTL8C.
TPV	TRAP PRIMER VALVE PPP INC. MODEL# PR-500, 1/2" INLET, 1/2" OUTLET	JOSAM #88300.	WATTS #A200.
WS	WATER CLOSET SUPPORTS JR SMITH MODEL# 0542F, VERTICAL HUB AND SPIGOT.	ZURN #1204	JOSAM STD. 4" HUB AND SPIGOT, 2" VENT.
US	URINAL SUPPORTS SMITH MODEL# 0637	ZURN #1221.	JOSAM #17550.
TMV	THERMOSTATIC MIXING VALVE LEONARD TM-15-E MIXING VALVE WITH CHECKSTOPS. INSTALL IN ACCESSIBLE LOCATION. SET OUTFLOW TO SPECIFIED TEMPERATURE (90 DEG F.). INSTALL PER MANUFACTURER'S SPECIFICATIONS.	WATTS MMV SERIES.	TACO 5000 SERIES.
HB	HOSE BIBB ZURN Z-1330-C, 3/4" WALL HYDRANT WITH VANDAL RESISTANT VACUUM BREAKER. ENCASED WITH KEY LOCK.	WATTS #HY-330.	JAY R. SMITH #5509QT.
SST	DRAINBACK SOLAR ELECTRIC WATER HEATING SYSTEM/TANK HOLOCENE TECHNOLOGIES DRAINBACK SOLAR WATER HEATING SYSTEM WITH 130 GALLON SOLAR STORAGE TANK (SST). PROVIDE PIPING TO EWH PER MFR SPECIFICATIONS. PROVIDE COLLECTOR PANELS ON ROOF AND ALL COMPONENTS (PIPING, VALVES, PUMP, ETC.) AS REQUIRED.	SOLAR DIRECT TRENDSETTER SYSTEM.	LEVEREDGE GUARDIAN DB SYSTEM.
EWH	ELECTRIC WATER HEATER A.O. SMITH MODEL DEN-80, 80 GALLON, 4,500 WATT, 30 GPH RECOVERY AT 60 DEGREE RISE, 3/4" INLET AND OUTLET, 208V, 1 PH. PROVIDE DRAIN PAN, PRESSURE RELIEF VALVE. PROVIDE EXPANSION TANK (ET) AMTROL MODEL ST-12-C 4.4 GALLON, STEEL CONSTRUCTION, STAMPED IN ACCORDANCE WITH THE ASME CODE FOR WORKING PRESSURE. FACTORY AIR PRECHARGED AND FIELD ADJUSTED. ALL WELDS MUST CONFORM TO ASME CODES, AND ALL INTERNAL PARTS MUST COMPLY WITH FDA REGULATIONS AND APPROVAL.	STATE PATRIOT PCE 82 WATER HEATER. STATE ETC-5X EXPANSION TANK.	RHEEM/RUUD ELD 80 WATER HEATER. WATTS DETA-12 EXPANSION TANK.
FS	FLOOR SINK ZURN PVC FLOOR SINK MODEL FD-2370-PV3, 12" X 12", FULL GRATE, WITH 3" PIPE CONNECTION.	OATEY #42721.	SIoux CHIEF #961.
FD	FLOOR DRAIN ZURN ZH-415. PROVIDE WITH DEEP SEAL P-TRAP, AND TYPE "B" STRAINER. PROVIDE VANDAL-PROOF TOP. PROVIDE MODEL WITH TRAP PRIMER CONNECTION ONLY FOR FLOOR DRAINS IN AREAS NOTED ON SHEET P2.	JOSAM #30000A.	JAY R. SMITH #2005-A.
FPHB	FREEZE-PROOF HOSEBIBB ZURN Z-1320-C, 3/4" NON FREEZE WALL HYDRANT WITH VANDAL RESISTANT VACUUM BREAKER. ENCASED WITH KEY LOCK.	JAY R. SMITH #5509QT.	WATTS HY-725.
RPZ	2" REDUCED PRESSURE BACKFLOW PREVENTER WATTS MODEL #009QT-2" REDUCED PRESSURE BACKFLOW PREVENTER, IRON CONSTRUCTION.	ZURN #375-2"	FEBCO #860-2"

*OR APPROVED EQUAL

GENERAL NOTES - PLUMBING

- PREPLAN ALL WORK PRIOR TO ORDERING, PURCHASING, OR FABRICATING ANY PART OF THE WORK DESCRIBED BY THIS DRAWING.
- IMMEDIATELY NOTIFY THE ENGINEER OF ANY CONFLICTS WITH EXISTING FIELD CONDITIONS OR THE WORK OF OTHER TRADES.
- RESOLVE ALL CONFLICTS PRIOR TO INCURRING ANY MATERIAL OR LABOR EXPENSES.
- COMPLY WITH THE MANUFACTURER'S TECHNICAL INSTRUCTIONS WHEN INSTALLING PLUMBING FIXTURES, MATERIALS, AND DEVICES.
- LOCATE FIXTURES AND EQUIPMENT GENERALLY AS SHOWN ON THE PLANS; HOWEVER, COORDINATE LOCATIONS WITH ACTUAL FIELD CONDITIONS TO PRESERVE ALL CODE-REQUIRED AND MANUFACTURER-REQUESTED SERVICE CLEARANCES.
- COORDINATE ROUTING OF ALL PIPING WITH BUILDING STRUCTURE AND WITH THE WORK OF OTHER TRADES. OFFSET VENT PIPING AROUND BEAMS AND JOISTS AS NECESSARY.
- ALL HANDICAP FIXTURES AND INSTALLATION OF HANDICAP FIXTURES SHALL CONFORM TO ADA REQUIREMENTS.
- AT EXTERIOR WALL, INSTALL WATER PIPING ON HEATED SIDE OF WALL INSULATION.
- PROVIDE WATER HAMMER ARRESTORS AT THE END OF EACH COLD AND HOT WATER BRANCH RISER. SIZE ARRESTOR APPROPRIATELY.
- PROVIDE CONCRETE RING FOR ALL EXTERIOR CLEAN-OUTS.
- REVIEW SITE PLAN FOR UTILITIES AND ORIENTATION PRIOR TO START OF WORK.
- G.C. TO PROVIDE ROOF PENETRATIONS.
- PROVIDE HTHW AT 120 DEGREES (F) AND LTHW AT 90 DEGREES (F).

SYMBOL LEGEND - PLUMBING

SYMBOL	DESCRIPTION
---	WASTE PIPING (W)
----	VENT PIPING (V)
----	COLD WATER PIPING (CW)
----	HOT WATER PIPING (HW)
----- HTHW -----	HIGH TEMPERATURE HOT WATER PIPING (HTHW) 140 DEG. F
----- LTHW -----	LOW TEMPERATURE HOT WATER PIPING (LTHW) 110 DEG. F
----- HWR -----	HOT WATER RETURN PIPING (HWR)
----- S -----	SOLAR COLLECTOR SUPPLY LINE
----- R -----	SOLAR COLLECTOR RETURN LINE
○ COFF	CLEANOUT FINISH FLOOR
⊥ WCO/HCO	WALL/HORIZONTAL CLEANOUT
⊕ COFG	CLEANOUT FINISH GRADE-PROVIDE FLUSH CONCRETE COLLAR AND BRONZE COVER
	DIELECTRIC UNION
⊗	SHUT-OFF VALVE
∩	CHECK VALVE
⊗	BALANCING VALVE
○	CIRCULATION PUMP (CP)
○	WATER METER (MTR)
⊥	VENT THRU ROOF (VTR)
⊥	THERMOSTATIC MIXING VALVE (TMV)
⊕	CONNECTION POINT FROM NEW TO EXISTING PIPING.

WATER HEATER SIZING

AMOUNT	ITEM	GPH
7	LAVATORY	35.0
1	CAN WASH	10.0
TOTAL		45.0 GPH

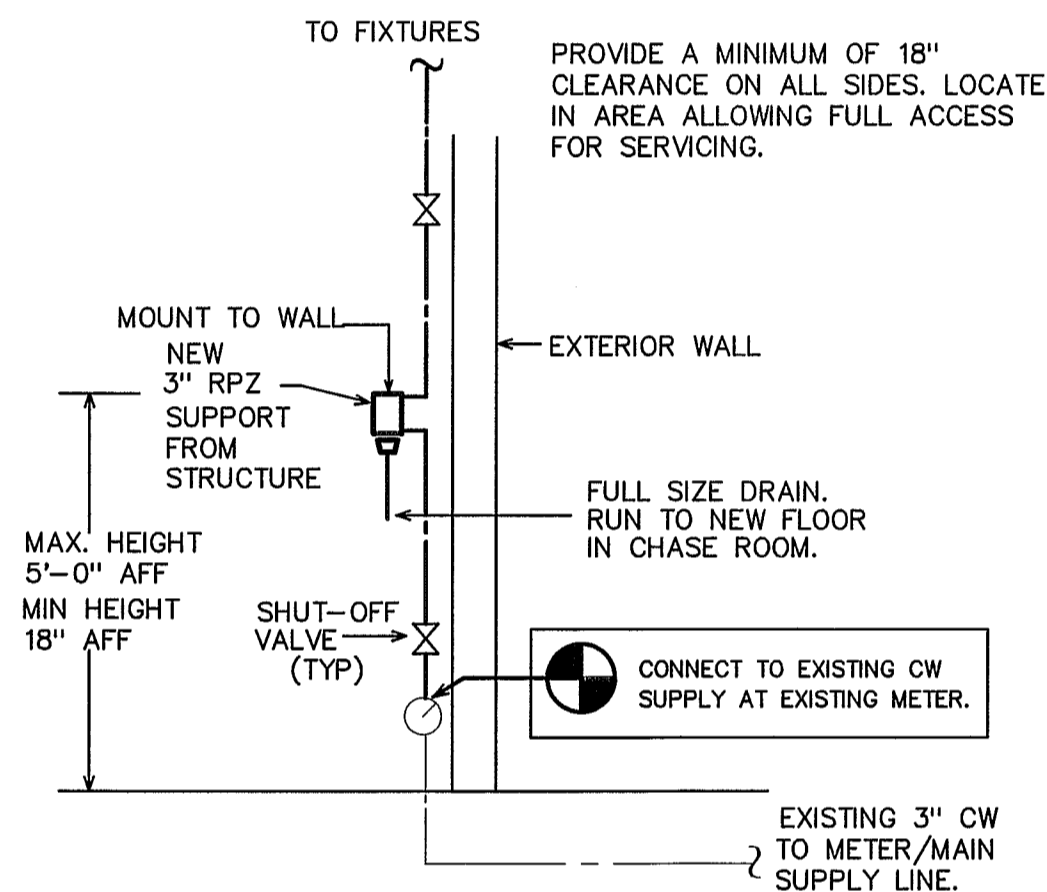

2 RPZ MOUNTING DETAIL
SCALE: NOT TO SCALE

NOTE: PROVIDE WATTS 9D BACKFLOW PREVENTER OR EQUAL ON SUPPLY LINE.

NOTE: ALL MOUNTING HEIGHTS SHALL MEET THE NCSBC AND ADA.

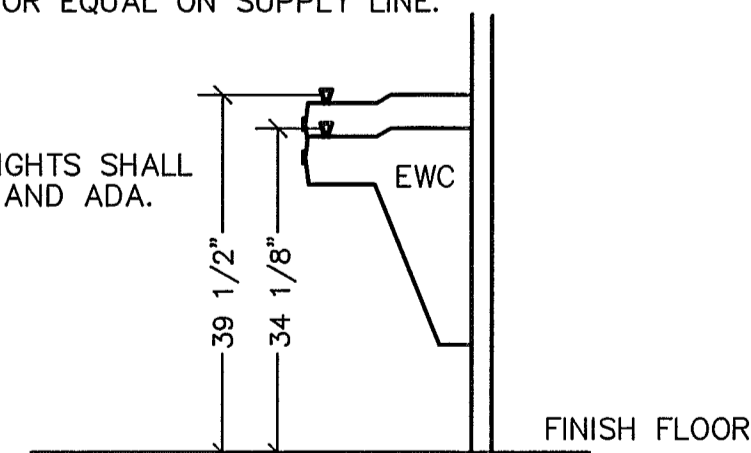

3 EWC DETAIL
SCALE: NOT TO SCALE

LOAD SUMMARY - PLUMBING

WASTE DEMAND (FD)	WATER DEMAND (FD)	WATER DEMAND (GPM)
66.0	114.5	69.7

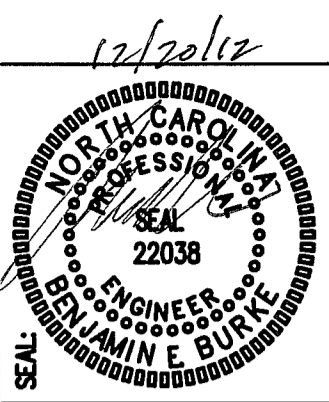

ENGINEER
BRIAN RESIEN, GROUP, P.C.
CONSULTING ENGINEERS
3305-109 Durham Drive
Raleigh, North Carolina 27603
919.771.1916 fax: 919.779.0826
email: bresien@ncrr.com
Corp. License # C-2652

FACILITIES DESIGN
ARCHITECTS & ENGINEERS
FACILITIES MANAGEMENT DIVISION, NCDOT
1 SOUTH WILMINGTON STREET
WILMINGTON, NORTH CAROLINA 27601



WASHINGTON COUNTY US-64
REST AREA/VISITOR CENTER
1248 US-64 EAST,
PLYMOUTH, NC 27962

PROJECT:

TIP PROJ. NO.	K-5000
WBS NO.	41532.3.1
CONTRACT ID NO.	
FEDERAL ID NO.	NHS-0064(158)

REVISIONS	NO.	DATE

DATE ISSUED: 10/9/12

DRAWN BY: DS

CHECKED BY: BEB

SHEET NO.

P1
1 OF 3

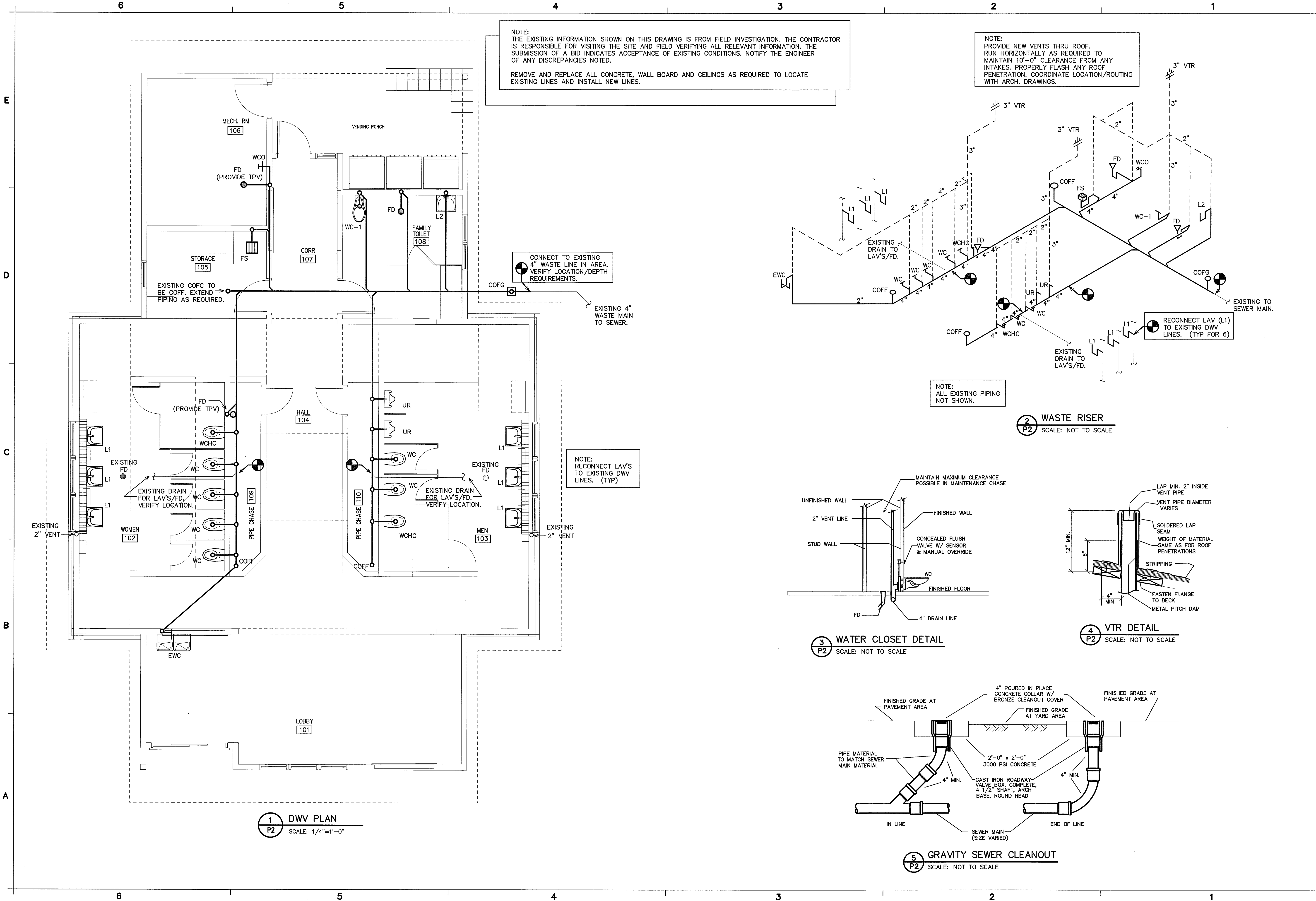

NOTE:
THE EXISTING INFORMATION SHOWN ON THIS DRAWING IS FROM FIELD INVESTIGATION. THE CONTRACTOR IS RESPONSIBLE FOR VISITING THE SITE AND FIELD VERIFYING ALL RELEVANT INFORMATION. THE SUBMISSION OF A BID INDICATES ACCEPTANCE OF EXISTING CONDITIONS. NOTIFY THE ENGINEER OF ANY DISCREPANCIES NOTED.

REMOVE AND REPLACE ALL CONCRETE, WALL BOARD AND CEILINGS AS REQUIRED TO LOCATE EXISTING LINES AND INSTALL NEW LINES.

NOTE:
PROVIDE NEW VENTS THRU ROOF. RUN HORIZONTALLY AS REQUIRED TO MAINTAIN 10'-0" CLEARANCE FROM ANY INTAKES. PROPERLY FLASH ANY ROOF PENETRATION. COORDINATE LOCATION/ROUTING WITH ARCH. DRAWINGS.

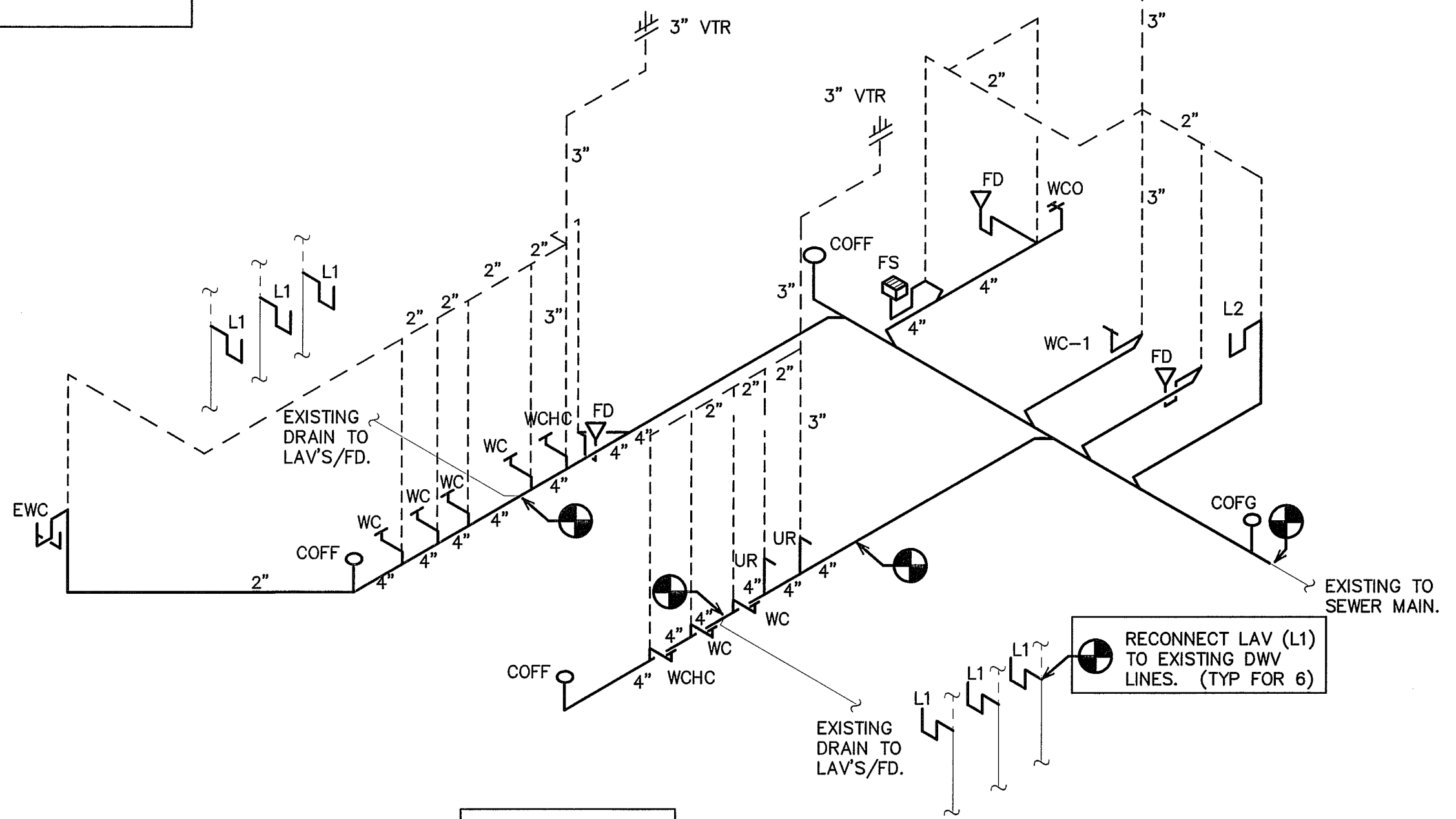

2 WASTE RISER
SCALE: NOT TO SCALE

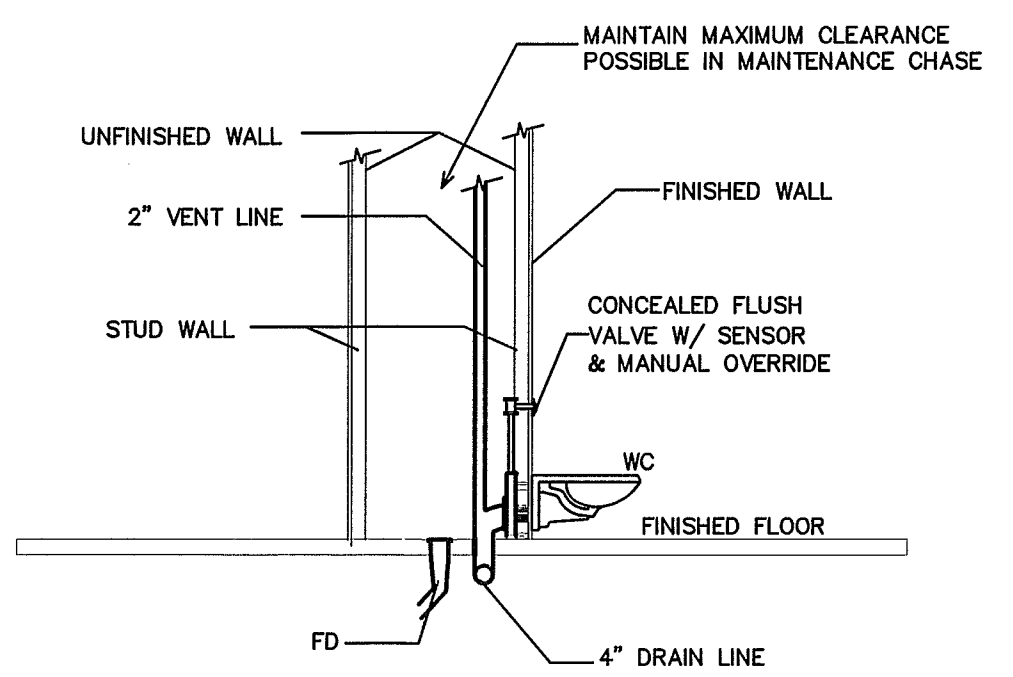

3 WATER CLOSET DETAIL
SCALE: NOT TO SCALE

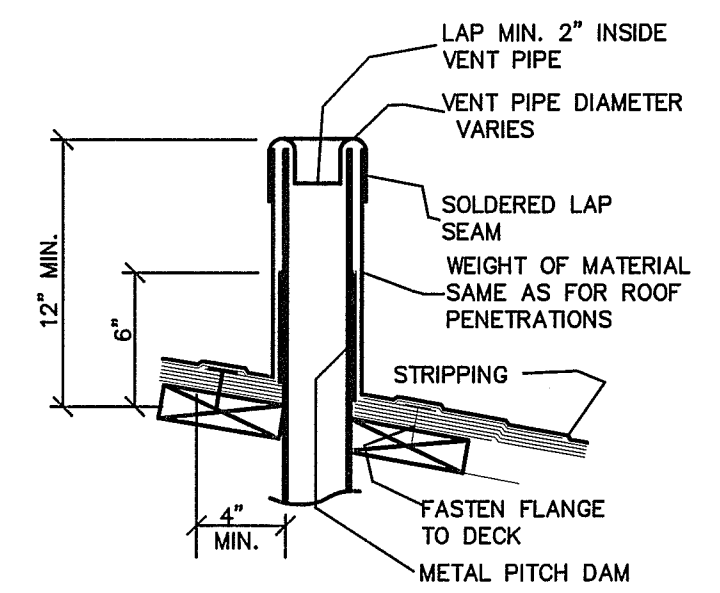

4 VTR DETAIL
SCALE: NOT TO SCALE

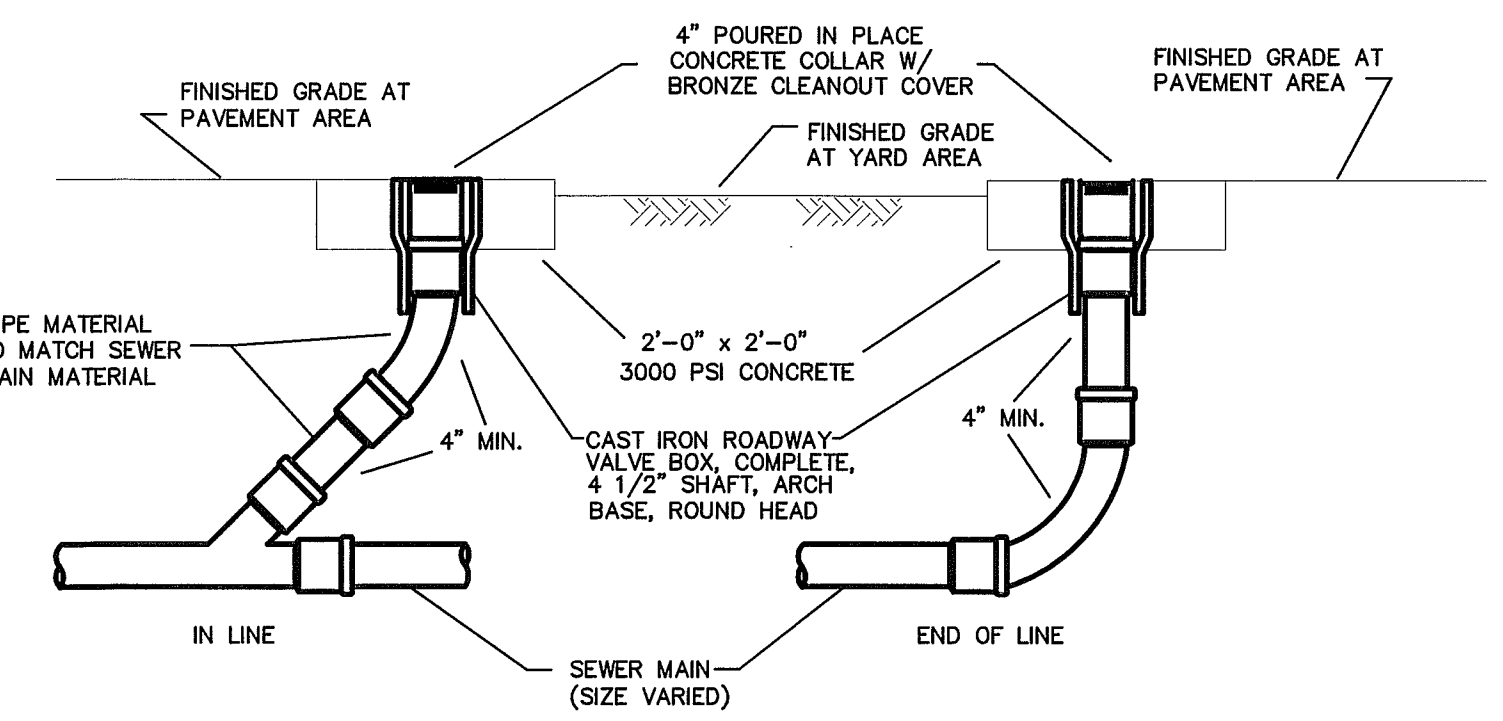

5 GRAVITY SEWER CLEANOUT
SCALE: NOT TO SCALE

1 DWV PLAN
SCALE: 1/4\"=1'-0\"

2/2012



SEAL
NORTH CAROLINA
PROFESSIONAL ENGINEER
22038
BENJAMIN E. BURT

ENGINEER
BLURKE DESIGN GROUP, P.A.
CONSULTING ENGINEERS
3305-09 Durham Drive
Raleigh, North Carolina 27603
919.771.1916 fax 919.779.0826
email: benburk@ncr.com
Corp. License # C-2652

BDG

FACILITIES DESIGN
ARCHITECTS & ENGINEERS
FACILITIES MANAGEMENT DIVISION, NCDOT
1000 W. Hargett Street, Suite 1000
Raleigh, NC 27601
919.771-0400 FAX: 919.771-0399
RALPH, NORTH CAROLINA 27601



STATE OF NORTH CAROLINA * DEPARTMENT OF TRANSPORTATION

WASHINGTON COUNTY US-64
REST AREA VISITOR CENTER
1248 US-64 EAST,
PLYMOUTH, NC 27962

PROJECT:

TIP PROJ. NO.	K-5000
WBS NO.	41532.3.1
CONTRACT ID NO.	
FEDERAL ID NO.	NHS-0064(158)

REVISIONS	
NO.	DATE

DATE ISSUED: 10/9/12
DRAWN BY: DS
CHECKED BY: BEB
SHEET NO.

P2

2 of 3

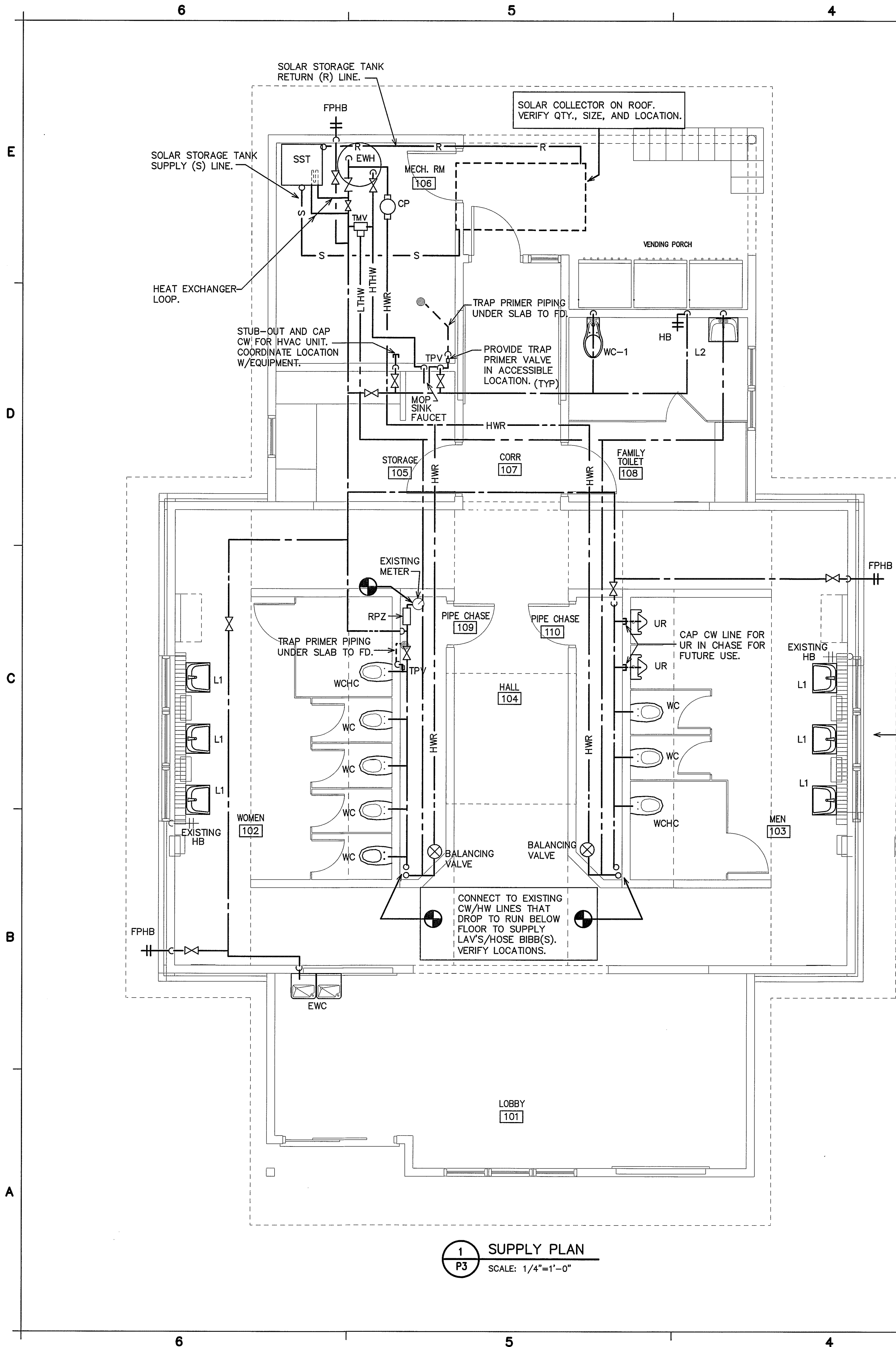

1 SUPPLY PLAN
P3 SCALE: 1/4"=1'-0"

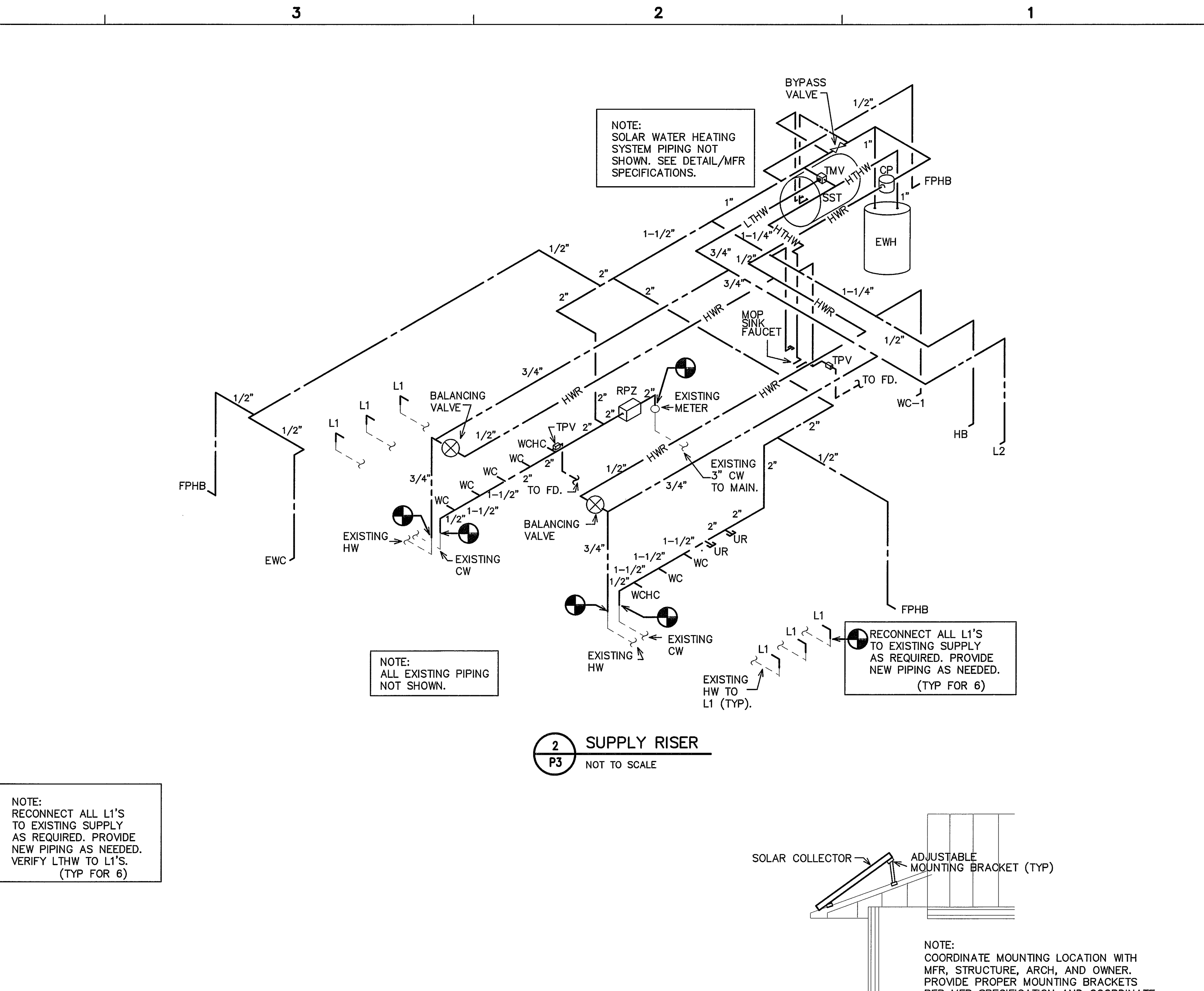

2 SUPPLY RISER
P3 NOT TO SCALE

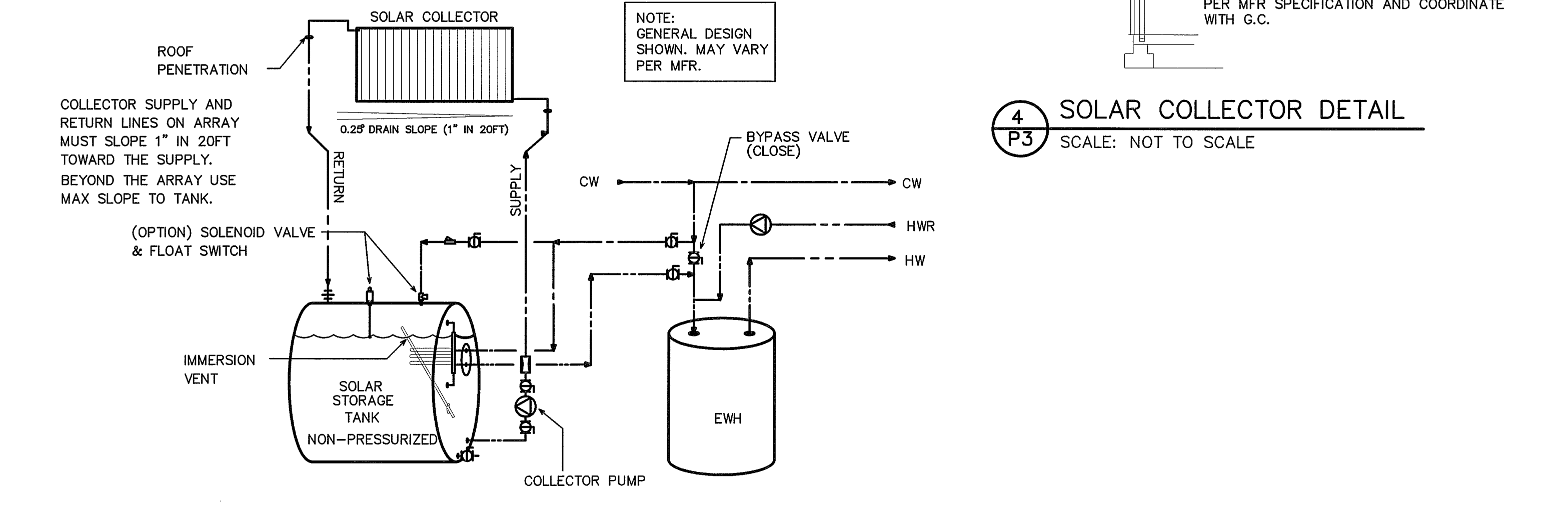

3 SOLAR WATER HEATER DETAIL
P3 SCALE: NOT TO SCALE

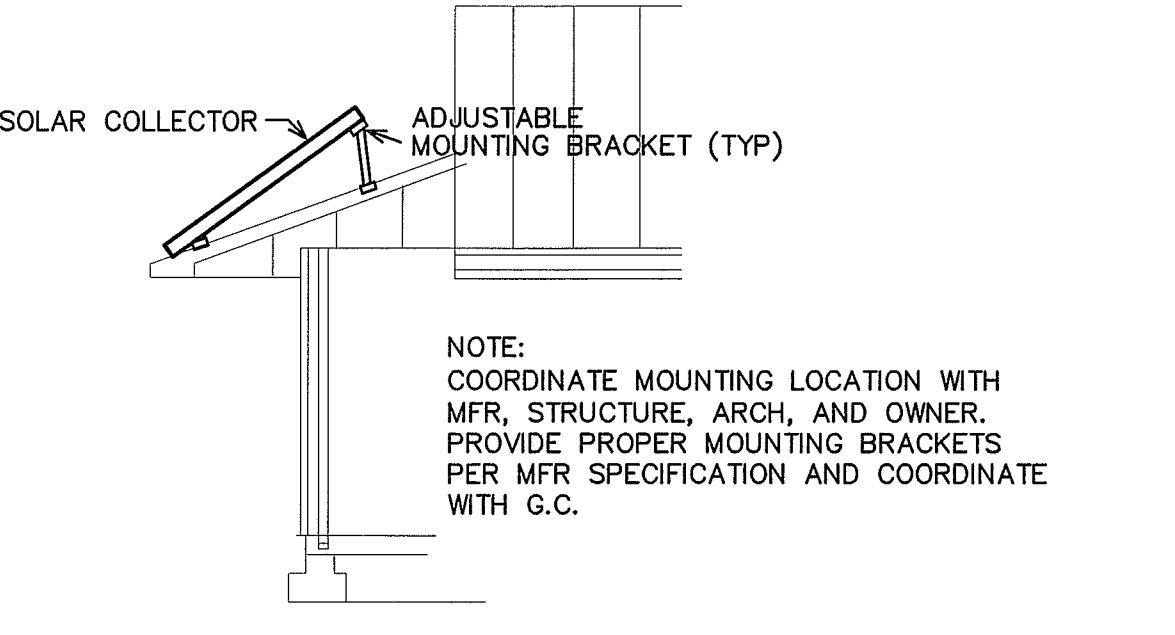

4 SOLAR COLLECTOR DETAIL
P3 SCALE: NOT TO SCALE

12/20/12

BLURKE DESIGN GROUP, P.A.
CONSTRUCTION ENGINEERS
3305-108 Durham Drive
Raleigh, North Carolina 27603
919.771.1816 fax: 919.779.0826
email: benburke@ncr.com
Corp. License # C-2652

BDG

FACILITIES DESIGN
ARCHITECTS & ENGINEERS
FACILITIES MANAGEMENT DIVISION, NCDOT
1000 SOUTH MAIN STREET
RALEIGH, NORTH CAROLINA 27601
919.771.1816 fax: 919.779.0826

WASHINGTON COUNTY US-64
REST AREA VISITOR CENTER
1248 US-64 EAST,
PLYMOUTH, NC 27962

PROJECT:

TIP PROJ. NO.	K-5000
WBS NO.	41532.3.1
CONTRACT ID NO.	
FEDERAL ID NO.	NHS-0064(158)

REVISIONS NO.	DATE

DATE ISSUED: 10/9/12
DRAWN BY: DS
CHECKED BY: BEB
SHEET NO.

P3

3 OF 3

AIR DISTRIBUTION SCHEDULE

MARK	* MANUFACTURER	MODEL NO.	FACE SIZE	NECK SIZE	MATERIAL	SERVICE	NOTES
A	CARNES	RADAH	14" X 6"	14" X 6"	ALUMINUM	SUPPLY	COLOR BY ARCHITECT SURFACE MOUNT
B	CARNES	SASA-40	-	8" DIA	ALUMINUM	SUPPLY	COLOR BY ARCHITECT SURFACE MOUNT
RA	CARNES	RAJAH	18" X 18"	18" X 18"	ALUMINUM	RETURN	COLOR BY ARCHITECT GYP CEILING MOUNT
EA	CARNES	RAJAH	18" X 12"	18" X 12"	ALUMINUM	EXHAUST	COLOR BY ARCHITECT SURFACE MOUNT

COORDINATE BORDER TYPE WITH THE CEILING/WALL TYPE. SEE ARCH SHEETS PROVIDE DUCT TRANSITIONS AS REQUIRED.
 * OR APPROVED EQUAL BY TUTTLE & BAILEY, OR METALAIR

HVAC EQUIPMENT SCHEDULE

WSP# #1	* CARRIER MODEL	DESCRIPTION
WATER SOURCE HEAT PUMP SYSTEM #1	#50PSV048JDC301J0	VERTICAL WATER SOURCE HEAT PUMP, 4 TON, 1600 CFM, 18.5 EER, 4.1 COP, 12 GPM WATER, 6.9 FAN FLA, 20.5 COMPRESSOR RLA, 208V. SINGLE PH, 33 MCA, 50 MCO. UNIT SHALL HAVE TOP DISCHARGE WITH RIGHT SIDE RETURN. 51,400 BTUH TOTAL COOLING, 34,200 BTUH SENSIBLE COOLING, 41,100 TOTAL HEATING.

* OR APPROVED EQUAL BY CLIMATE MASTER, FLORIDA HEAT PUMP, OR TRANE.

- NOTES:
- PROVIDE FACTORY HOSE KIT THAT INCLUDES SHUT-OFF BALL VALVES, BALANCING VALVE ETC., FILTER RACK WITH 2" FILTERS.
 - PROVIDE MINIMUM OUTDOOR AIR FLOW SETTINGS AS PER PLAN.
 - FAN BASED ON 1/2" EXT. WATER COLUMN STATIC.
 - OR EQUAL BY CLIMATE MASTER OR MAMOUTH
 - PROVIDE CONTROLS SO THAT ERV AND GEOTHERMAL LOOP CIRCULATING PUMP ARE ENERGIZED WHEN HEAT PUMP IS RUNNING.
 - PROVIDE PROGRAMMABLE, AUTOMATIC CHANGEOVER, DIGITAL THERMOSTAT WITH REMOTE SENSOR.

PUMP SCHEDULE

MARK	SERVICE	FLOW (GPM)	HEAD (FT)	RPM	MIN. EFF.	ELECTRICAL			TYPE	* B&G MODEL OR APPROVED EQUAL
						HP	VOLTAGE	PHASE		
P-1	GEOTHERMAL LOOP	12	40	3250	68	0.4	115	1	IN-LINE	PL-55

* OR APPROVED EQUAL BY TACO OR ARMSTRONG.

EXPANSION TANK SCHEDULE

MARK	VOLUME (GAL.)	VOLUME ACCEPTANCE (GAL.)	SIZE		NO. OF TANKS	REMARKS	B&G MODEL OR APPROVED EQUAL
			DIAMETER	HEIGHT			
ET-1	14	11.3	15	21"	1	GEOTHERMAL LOOP	HFT-90

* OR APPROVED EQUAL BY TACO OR ARMSTRONG

EXHAUST FAN SCHEDULE

EF-#1	* CARNES MODEL#	DESCRIPTION
EF-1	VCD010C	EXHAUST FAN, 93 CFM @ 1/4" SP, 640 RPM, 1.1 AMPS, 120V. THE ELECTRICAL CONTRACTOR SHALL PROVIDE THE SWITCH AND WIRE THE UNIT. THE HVAC CONTRACTOR SHALL PROVIDE UNIT, 6" RIGID DUCT TO EXTERIOR ROOF CAP. LOCATE EXHAUST TERMINATION A MINIMUM OF 10'-0" FROM ANY INTAKES.

* OR APPROVED EQUAL BY GREENHECK OR ACME

ENERGY RECOVERY UNIT SCHEDULE

EQUIP. NUMBER	MODEL NO.	FLOW	THERMAL PERFORMANCE														NOTES:		
			FANS / MOTORS					DESIGN CONDITIONS				ERV OUTLET CONDITIONS		ENERGY RECOVERY (THERMAL) CAPACITY					
			STATIC PRESSURE (EXTERNAL)	FAN MOTORS (FAN POINT)	FLA (FOR UNIT SINGLE POINT)	VOLTS/PHASE/HZ	MCA	FUSE/CB MAX	OUTSIDE AIR TEMP (F) & HUMIDITY (DB) / (WB OR RH)	ROOM AIR TEMP (F) & HUMIDITY (DB) / (WB OR RH)	LEAVING AIR TEMP (F) & HUMIDITY (DB) / (WB)	Cooling Capacity (MBH / TON)	Heating Capacity (MBH)						
ERV-1	RENEWAIRE HEIXNH	800 CFM	0.50IN H ₂ O	(2) FOR FANS (1) FOR WHEEL	10.2 A	208-230V 1 PH 60 HZ	11.5 A	15 A	94F / 78F	23F / 19	75F / 50%	72F / 50%	SUMMER WINTER	SUMMER WINTER	SUMMER WINTER	TOTAL	TOTAL	44.82	ALL

- NOTES:
- FLOW & LOADS BASED ON ARI-1060 PERFORMANCE & CERTIFIED CORE.
 - NOT USED.
 - VENTILATION TYPE: STATIC PLATE, HEAT & HUMIDITY TRANSFER.
 - INCLUDE INTEGRAL DISPOSABLE FILTERS (OUTSIDE AND ROOM AIR) WITH MERV8 OR BETTER RATING.
 - INCLUDE SINGLE POINT ELECTRICAL POWER CONNECTION.
 - HOUSING SHALL BE GALVANIZED, .20 GAUGE (OR THICKER) STEEL WITH LAPPED CORNERS.
 - OR EQUALS BY SEMCO, OR THYBAR.
 - SERVICE ACCESS DOORS SHALL BE GASKETED & PROVIDE ACCESS FOR MAINTENANCE OF ALL COMPONENTS.
 - INCLUDE INSULATION ON ALL CASE WALLS & DOORS.
 - INCLUDE THERMALLY PROTECTED MOTORS WITH STARTERS.
 - UL LISTED 1995
 - PROVIDE WITH FUSED DISCONNECT SWITCH.

MECHANICAL SYSTEMS AND EQUIPMENT

METHOD OF COMPLIANCE:

Prescriptive Energy Cost Budget

Thermal Zone 3A

Exterior Design Conditions

winter dry bulb 23 F
summer dry bulb 94 F

Interior Design Conditions

winter dry bulb 72 F
summer dry bulb 75 F
relative humidity 50%

Building Heating Load 59,600 BTU/hr
-44,825 BTU/hr (heat wheel reduction)
14,775 BTU/hr

Building Cooling Load 65,100 BTU/hr
-20,133 BTU/hr (heat wheel reduction)
44,867 BTU/hr

Mechanical Spacing Conditioning System

Unitary - The building is served by (1) 4 ton water source geothermal heat pump with an energy recovery ventilator.

Boiler - Not applicable to this project.
Chiller - Not applicable to this project.

Equipment efficiencies

Efficiencies and outputs are listed on equipment schedules - See drawings.

Equipment schedules with motors.

Motors used on this project are included in the efficiency rating of the unit. See drawings for efficiencies.

GENERAL NOTES - MECHANICAL

- ALL WORK SHALL BE IN ACCORDANCE WITH THE LATEST EDITION OF THE STATE CODE AND ALL LOCAL AND OTHER APPLICABLE CODES.
- ANY PERMITS AND INSPECTION FEES SHALL BE SECURED AND PAID FOR BY THE MECHANICAL CONTRACTOR (MC).
- ALL WORK SHALL BE PERFORMED BY EXPERIENCED AND SKILLED CRAFTSMEN. THE MC SHALL COORDINATE ALL OF HIS WORK WITH THE GENERAL CONTRACTOR (GC) AND OTHER TRADES.
- THE LOCATION OF ALL DUCT, PIPING AND EQUIPMENT SHALL BE ADJUSTED TO ACCOMMODATE ANTICIPATED OR ENCOUNTERED INTERFERENCES.
- THESE PLANS ARE DIAGRAMMATIC AND MAY NOT SHOW MINOR DETAILS AND LOCATIONS. FOR DIMENSIONS REFER TO THE ARCHITECTURAL PLANS.
- THE MC SHALL BE RESPONSIBLE FOR ALL ELECTRICAL STARTERS INTERLOCKS, CONTROL WIRING CONDUIT AND POWER WIRING FROM DISCONNECTS TO HIS EQUIPMENT, USING A LICENSED ELECTRICIAN.
- THE MC SHALL USE FIRE DAMPERS FOR PROTECTION OF THE OPENING IN ACCORDANCE WITH STATE AND LOCAL CODES IN ALL LOCATIONS WHERE PENETRATIONS OF RATED WALLS AND FLOORS OCCUR. SEE ARCHITECTURAL PLANS FOR RATED WALL AND FLOOR LOCATIONS. PROVIDE ACCESS DOORS AT ALL DAMPER LOCATIONS. LOCATE DOORS FOR EASY ACCESS. THERE ARE NO RATED WALLS PENETRATED IN THIS HVAC UPFIT.
- INSTALL FLEXIBLE CONNECTORS ON SUPPLY AND RETURN DUCTWORK AHU. ALL MECHANICAL EQUIPMENT SHALL OPERATE FREE OF OBJECTIONAL NOISE AND VIBRATION.
- INSTALL TURNING VANES IN SUPPLY DUCTS AT ALL ELBOWS AND SPLITTER DAMPERS. PROVIDE BALANCING DAMPERS IN ALL DUCTS WHERE SHOWN OR REQUIRED FOR SYSTEM BALANCING. PROVIDE SPIN IN STARTING COLLARS WITH DAMPERS AT ALL SUPPLY TAKEOFFS.
- DUCT DIMENSIONS ARE SHOWN INSIDE CLEAR. COORDINATE EXACT SIZE WITH SPACE AVAILABLE. DUCT INSULATION SHALL BE 2" FIBERGLASS EXTERIOR DUCT INSULATION WITH FOIL FACING.
- THERMOSTAT, WIRING AND CONDUIT ARE TO BE FURNISHED BY THE MC. MOUNT THERMOSTAT 48" ABOVE THE FINISHED FLOOR. COORDINATE LOCATION WITH OWNER. PROVIDE AUTO CHANGEOVER THERMOSTAT WITH UNIT OFF POSITION AS MINIMUM. PROVIDE AN EMERGENCY SHUT-OFF SWITCH ABOVE THE THERMOSTAT. PROPERLY LABEL SHUT-OFF SWITCH.
- THE MC SHALL KEEP THE PREMISES CLEAR OF DEBRIS FROM HIS WORK DURING CONSTRUCTION AND LEAVE THE AREA AND BUILDING CLEAN AT THE COMPLETION OF HIS WORK. HE SHALL ALSO LEAVE CLEAN ALL EXPOSED EQUIPMENT IN HIS CONTRACT.
- COORDINATE DIFFUSER AND CEILING EXHAUST GRILLE LOCATIONS WITH LIGHTS AND GRID. COORDINATE MOUNTING FRAME WITH CEILING TYPE.
- THE M.C. SHALL COORDINATE WITH AND PROVIDE EQUIPMENT SPEC. SHEETS TO THE GENERAL AND ELECTRICAL CONTRACTORS FOR REVIEW PRIOR TO ORDERING EQUIPMENT.
- PROPERLY SUPPORT FLEXIBLE DUCT, MINIMUM 75% DEFORMATION. PROVIDE SHEET METAL ELBOWS AT ALL 90 DEGREE BENDS.
- ALL DUCT JOINTS SHALL BE SEALED AIRTIGHT WITH FIBER ENPREGNATED MASTIC OR HARDCAST AND TAPE.
- SUPPORT AHU, EXHAUST FANS, HEAT WHEEL AND ALL DUCTWORK, ETC. FROM STRUCTURE. PIPE STRAPPING WILL NOT BE ALLOWED.

LEGEND - MECHANICAL

- 12 X 8 RECTANGULAR GALVANIZED STEEL DUCTWORK
- 12" DIA. RIGID ROUND GALVANIZED STEEL DUCTWORK
- SUPPLY DIFFUSER
- RETURN GRILLE
- THERMOSTAT WITH LOCKING, VANDAL PROOF COVER
- REMOTE WALL MOUNTED TEMPERATURE SENSOR
- GRILLE TYPE
- MIN. CFM

OUTDOOR AIR CALCULATIONS

APPLICATION	CFM/FLUSHING FIXTURE
GANG TOILET ROOM	70 CFM EACH
10 FLUSHING FIXTURES X 70 CFM = 700 CFM	
800 CFM EXHAUST PROVIDED BY ERV	
APPLICATION	CFM/FLUSHING FIXTURE
FAMILY TOILET ROOM	50 CFM EACH
1 FLUSHING FIXTURE X 50 CFM = 50 CFM	
50 CFM EXHAUST PROVIDED BY INDIVIDUAL INTERMITTENT FAN	
APPLICATION	CFM/SQ.FT.
CORRIDORS	0.08 CFM/SQ.FT.
630 SQ. FT. X 0.08 CFM/SQ.FT. = 50 CFM	
TOTAL OUTSIDE AIR REQUIRED - 800 CFM	
WSP# #1 = 800 CFM PROVIDED	

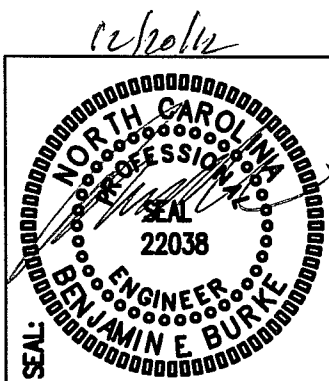

ENGINEER
BDU
 BURKE DESIGN GROUP, P.A.
 CONSULTING ENGINEERS
 9306-109 Durham Drive #7803
 Raleigh, NC 27603
 919.771.1916 fax 919.779.0926
 email: burkew@bduinc.com
 Corp. License # C-2652

FACILITIES DESIGN
 ARCHITECTS & ENGINEERS
 FACILITIES MANAGEMENT DIVISION, NCDOT
 1 SOUTH WASHINGTON STREET
 RALEIGH, NORTH CAROLINA 27601
 919.715-0400 FAX: 919.715-2700

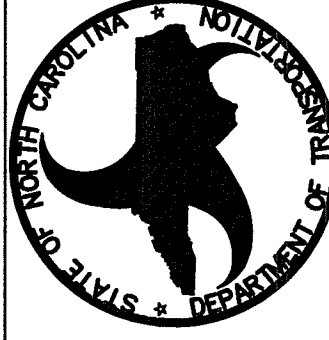

PROJECT:
WASHINGTON COUNTY US-64 REST AREA/VISITOR CENTER
 1248 US-64 EAST, PLYMOUTH, NC 27962

TIP PROJ. NO.	K-5000
WBS NO.	41532.3.1
CONTRACT ID NO.	
FEDERAL ID NO.	NHS-0064(158)

REVISIONS
 NO. DATE

DATE ISSUED: 10/9/12
 DRAWN BY: WBE
 CHECKED BY: BEB
 SHEET NO.

M1
 1 OF 2

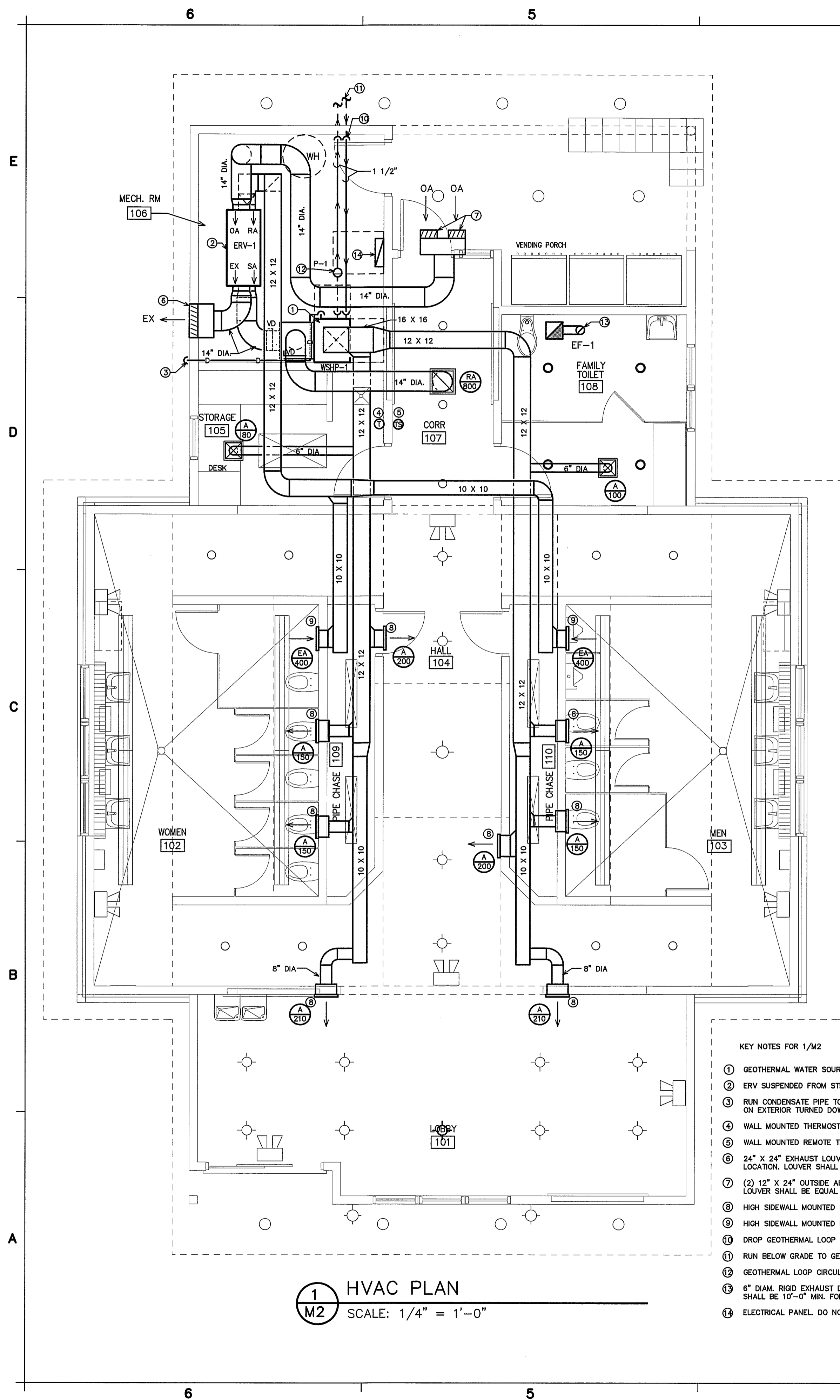

1 HVAC PLAN
M2 SCALE: 1/4" = 1'-0"

KEY NOTES FOR 1/M2

- ① GEOTHERMAL WATER SOURCE HEAT PUMP, MOUNT ON 4" THICK CONCRETE PAD.
- ② ERV SUSPENDED FROM STRUCTURE MAINTAIN 6'-0" CLEARANCE AFF. SEE DETAIL 3/M2.
- ③ RUN CONDENSATE PIPE TO EXTERIOR. INSULATE PIPE FOR ENTIRE LENGTH. TERMINATE PIPE ON EXTERIOR TURNED DOWN IN PLANTED AREA.
- ④ WALL MOUNTED THERMOSTAT, MOUNT AT 48" AFF.
- ⑤ WALL MOUNTED REMOTE TEMPERATURE SENSOR.
- ⑥ 24" X 24" EXHAUST LOUVER. SEE ARCHITECTURAL ELEVATIONS FOR EXACT LOUVER LOCATION. LOUVER SHALL BE EQUAL TO CARNES MODEL FKAA. COLOR AS SELECTED BY ARCHITECT.
- ⑦ (2) 12" X 24" OUTSIDE AIR INTAKE LOUVERS IN GABLE END. SEE ARCHITECTURAL ELEVATIONS FOR EXACT LOUVER LOCATION. LOUVER SHALL BE EQUAL TO CARNES MODEL FKAA. COLOR AS SELECTED BY ARCHITECT.
- ⑧ HIGH SIDEWALL MOUNTED SUPPLY AIR REGISTER.
- ⑨ HIGH SIDEWALL MOUNTED EXHAUST GRILLE.
- ⑩ DROP GEOTHERMAL LOOP WATER PIPING BELOW SLAB.
- ⑪ RUN BELOW GRADE TO GEOTHERMAL WELLS ON SITE.
- ⑫ GEOTHERMAL LOOP CIRCULATING PUMP.
- ⑬ 6" DIAM. RIGID EXHAUST DUCT UP TO ROOF MOUNTED EXHAUST CAP. EXHAUST DISCHARGE SHALL BE 10'-0" MIN. FROM ANY OUTSIDE AIR INTAKE.
- ⑭ ELECTRICAL PANEL. DO NOT RUN PIPING OR DUCT OVER PANEL.

2 DUCT CONSTRUCTION DETAILS
M2 SCALE: NOT TO SCALE

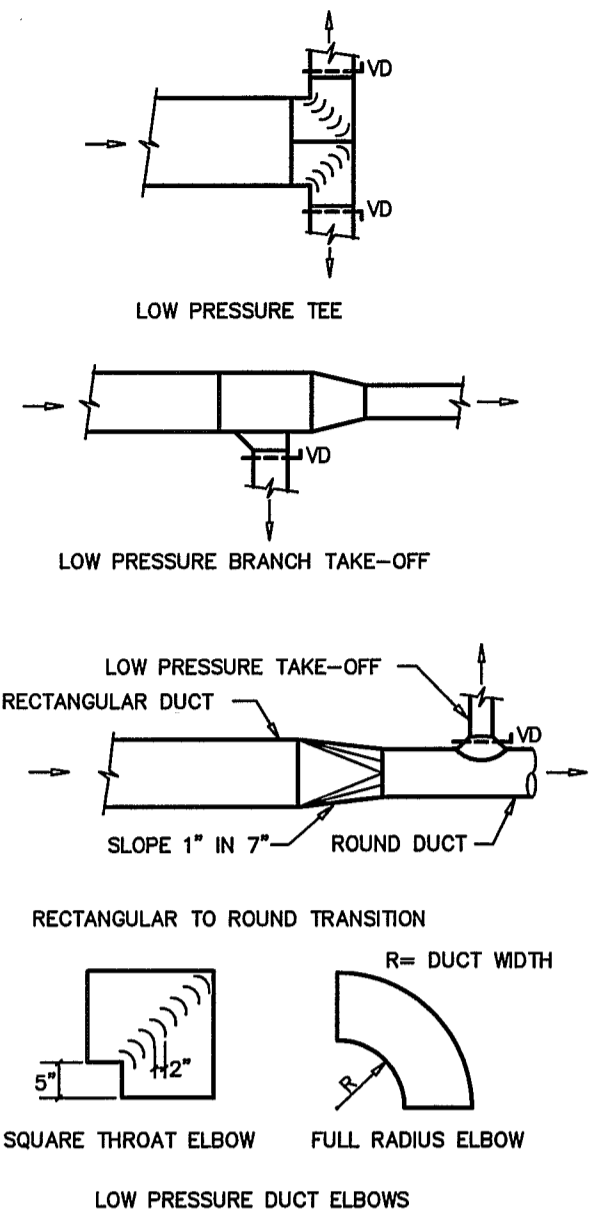

KEY NOTES FOR 3/M2

- ① 4" THICK CONCRETE PAD.
- ② ENERGY RECOVERY VENTILATOR SUSPENDED FROM STRUCTURE WITH (4) 1/2" THREADED STEEL RODS. PROVIDE ALL MANUFACTURER'S REQUIRED CLEARANCES.
- ③ WATER SOURCE HEAT PUMP UNIT. PROVIDE ALL MANUFACTURER'S REQUIRED CLEARANCES.
- ④ MANUAL BALANCING DAMPER WITH LOCKING QUADRANT.
- ⑤ 14" DIA. EXHAUST DUCT TO WALL EXHAUST LOUVER.
- ⑥ FLEXIBLE CONNECTIONS ON ALL DUCT CONNECTIONS TO EQUIPMENT. (TYPICAL).

3 MECHANICAL ROOM SECTION
M2 SCALE: 3/8" = 1'-0"

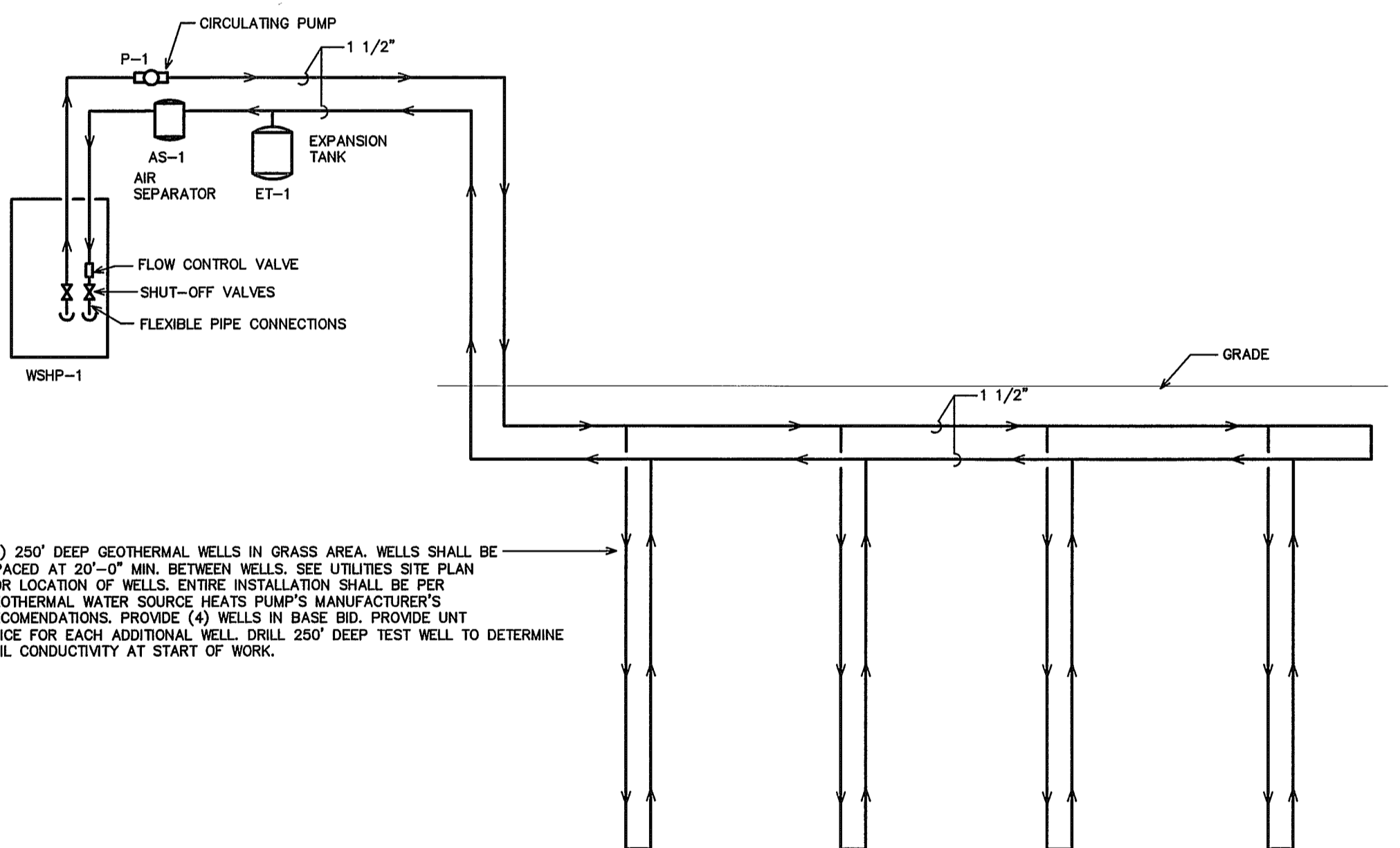
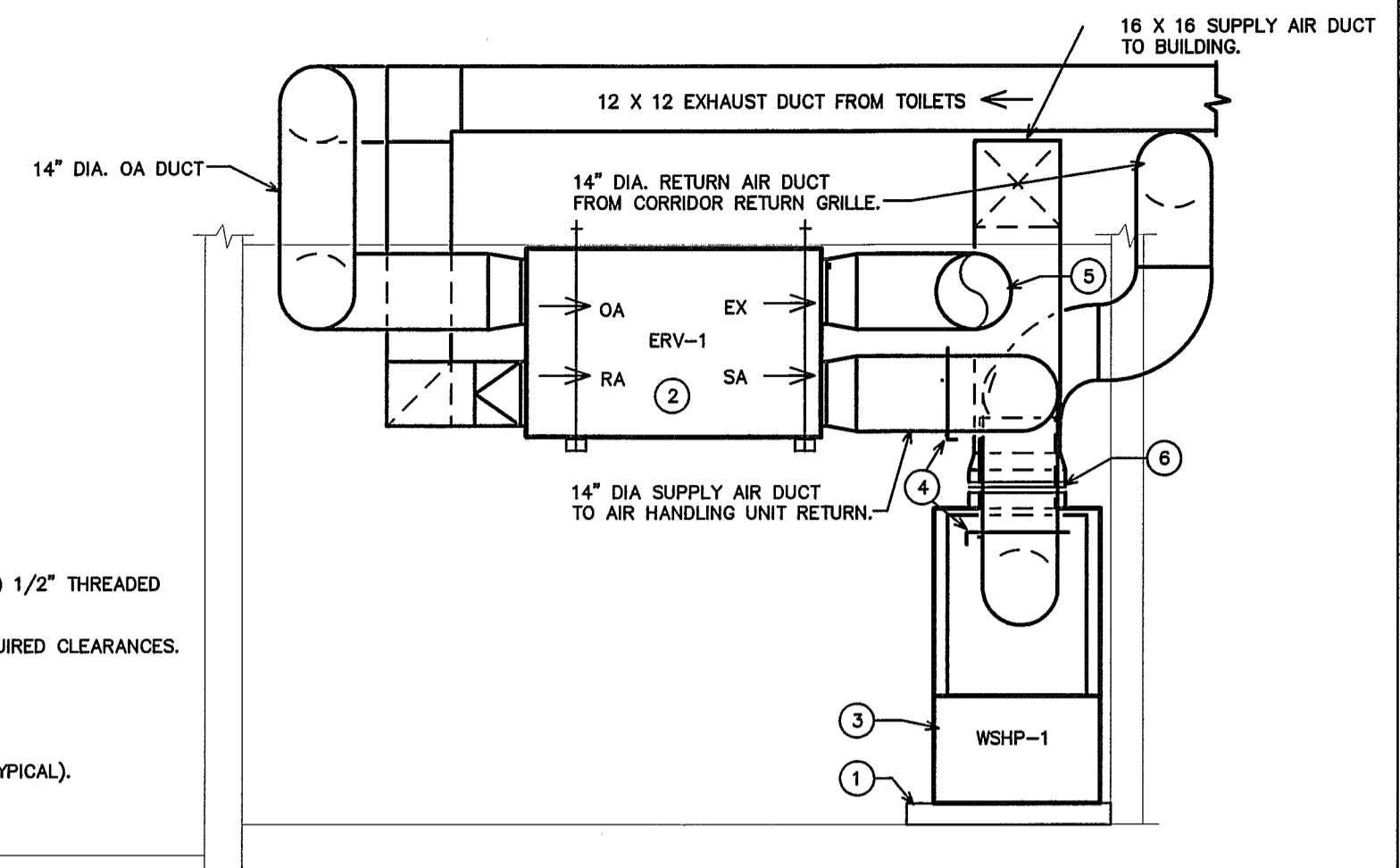

(4) 250' DEEP GEOTHERMAL WELLS IN GRASS AREA. WELLS SHALL BE SPACED AT 20'-0" MIN. BETWEEN WELLS. SEE UTILITIES SITE PLAN FOR LOCATION OF WELLS. ENTIRE INSTALLATION SHALL BE PER GEOTHERMAL WATER SOURCE HEATS PUMP'S MANUFACTURER'S RECOMMENDATIONS. PROVIDE (4) WELLS IN BASE BID. PROVIDE UNIT PRICE FOR EACH ADDITIONAL WELL. DRILL 250' DEEP TEST WELL TO DETERMINE SOIL CONDUCTIVITY AT START OF WORK.

4 GEOTHERMAL LOOP SCHEMATIC
M2 SCALE: NOT TO SCALE

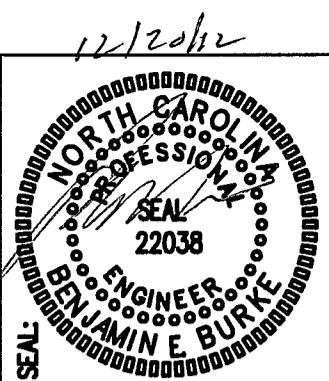

ENGINEER
M2
12/20/12

FACILITIES DESIGN
ARCHITECTS & ENGINEERS
FACILITIES MANAGEMENT DIVISION, NCDOT
1 SOUTH WILMINGTON STREET
RALEIGH, NORTH CAROLINA 27601
919.778-0400 FAX: 919.715-27601



PROJECT:
WASHINGTON COUNTY US-64
REST AREA VISITOR CENTER
1248 US-64 EAST,
PLYMOUTH, NC 27962

TIP PROJ. NO.	K-5000
WBS NO.	41532.3.1
CONTRACT ID NO.	
FEDERAL ID NO.	NHS-0064(158)
REVISIONS	
NO.	DATE

DATE ISSUED: 10/9/12
DRAWN BY: WBE
CHECKED BY: BEB

SHEET NO.
M2
2 OF 2

GENERAL NOTES

- ALL ELECTRICAL WORK SHALL BE IN ACCORDANCE WITH THE NATIONAL ELECTRICAL CODE AND ALL LOCAL CODES HAVING JURISDICTION.
- ALL BRANCH CIRCUIT CONDUCTORS TO BE COPPER (SERVICE CONDUCTORS MAY BE ALUMINUM WITH SAME AMPACITY AS COPPER CONDUCTORS. RE-SIZE CONDUCTORS AND CONDUIT PER NEC).
- ALL CIRCUITS TO BE 2 #12, 1 #12 GND IN 1/2" EMT CONDUIT AS A MINIMUM. PROVIDE WIRING FOR LARGER CIRCUITS AS REQUIRED BY NEC. RIGID CONDUIT IS REQUIRED WHERE EXPOSED BELOW 8'-0" A.F.F.
- ALL EMPTY CONDUIT RUNS IN EXCESS OF 10 FEET SHALL BE PROVIDED WITH A PULL WIRE OR FISH TAPE/CORD.
- CONTRACTOR SHALL VERIFY THAT ALL DOOR SWINGS ARE CORRECT BEFORE INSTALLING LIGHT SWITCH OUTLETS.
- ALL BRANCH CIRCUIT CONDUCTORS FROM THE PANEL TO THE FIRST OUTLET SHALL BE INCREASED TO THE NEXT LARGER SIZE WHERE THE LENGTH OF HOME RUN EXCEEDS 120 FT ON 120V AND 208V CIRCUITS.
- THE CORRECT NUMBER OF WIRES MAY NOT BE INDICATED FOR ALL CIRCUITS, ONLY THOSE WHERE CLARIFICATION IS NECESSARY. THE EC SHALL PROVIDE ALL WIRES NECESSARY FOR THE PROPER FUNCTION OF THE SYSTEM WHETHER INDICATED ON DRAWINGS OR NOT.
- THE CONTRACTOR SHALL BE RESPONSIBLE FOR CORRECTLY PHASING THE CIRCUITS IN THE PANELBOARDS.
- THE EC SHALL VERIFY THE TYPE OF CEILING SYSTEM WITH THE GC TO ENSURE THAT ALL LIGHTING FIXTURES ARE COMPATIBLE WITH THE CEILING SYSTEM BEING INSTALLED. LIGHTING FIXTURES SHOULD NOT BE ORDERED UNTIL TYPE OF CEILING HAS BEEN VERIFIED.
- ELECTRICAL REQUIREMENTS INDICATED ON DRAWINGS MAY DIFFER FROM ACTUAL EQUIPMENT FURNISHED. IF FURNISHED EQUIPMENT DIFFERS FROM RATINGS ON DRAWINGS CONTRACTOR SHALL NOTIFY ARCHITECT/ENGINEER FOR APPROPRIATE ACTION TO BE TAKEN.
- IT SHALL BE THE RESPONSIBILITY OF THE EC TO COORDINATE EXACT BREAKER REQUIREMENTS FOR ALL EQUIPMENT PRIOR TO ORDERING PANEL. ADJUST BREAKER AND WIRE SIZES AS REQUIRED.
- THE EC SHALL PROVIDE ALL DISCONNECTS FOR MECHANICAL AND PLUMBING EQUIPMENT DISCONNECTS SHALL BE PER MANUFACTURERS RECOMMENDATIONS AND FUSED PER NAME PLATE. PROVIDE NEMA-3R ENCLOSURES ON EXTERIOR. COORDINATE FUSE SIZES.
- THE EC SHALL MEET WITH THE ARCHITECT AND TENANT PRIOR TO INSTALLING OUTLET BOXES TO VERIFY LOCATIONS AND MOUNTING HEIGHTS OF RECEPTACLES.

GENERAL LEGEND

- 2X4 FLUORESCENT LIGHT FIXTURE: LETTER DENOTES TYPE OF LIGHT FIXTURE (REFER TO LIGHTING PLAN AND FIXTURE SCHEDULE).
- CEILING MOUNTED CABINET EXHAUST FAN
- DUPLEX RECEPTACLE - 120V; MOUNT 18" TO CENTER AFF UNLESS NOTED OTHERWISE; WP INDICATES WEATHER PROOF, GFI INDICATES GROUND FAULT CURRENT INTERRUPT PROTECTED.
- QUADRAPLEX RECEPTACLE - 120V
- LIGHT SWITCH - 120V
- (M) DENOTES A SWITCH WITH INTEGRAL MOTION SENSOR FOR AUTOMATIC SHUT-OFF WITH UP TO 2 HOUR ADJUSTABLE DELAY.
- JUNCTION BOX
- SINGLE-POLE HOMERUN TO PANELBOARD
- TWO-POLE OR 3-POLE HOMERUN TO PANELBOARD
- COMBINATION EXIT SIGN & EMERGENCY LIGHT
- EMERGENCY LIGHT
- BRANCH CIRCUIT WIRING
- SWITCH LEG
- GROUND CONNECTION
- DISTRIBUTION PANELBOARD
- DISCONNECTING MEANS AS REQUIRED BY CODE; 208V, CLASS 3130
- LIGHT SENSOR. ORIENTATION AS DIRECTED BY MANUFACTURER.
- EXTERIOR PHOTOCELL. PROVIDE PHOTOCELL AS REQUIRED TO SWITCH EXTERIOR FIXTURES. PROVIDE SHIELDING AS REQUIRED TO BLOCK ARTIFICIAL LIGHT. COORDINATE LOCATION.

ELECTRICAL SYSTEMS AND EQUIPMENT

METHOD OF COMPLIANCE
 PRESCRIPTIVE X PERFORMANCE _____ ENERGY COST BUDGET _____

Provide a standard riser diagram which indicates designated points for check metering
 Provide a standard panel schedule description which identifies different enduse loads.

Lighting schedule:

lamp type required in fixture
 number of lamps in fixture
 ballast type used in fixture
 number of ballasts in fixture
 total wattage in fixture
 total interior wattage specified vs. allowed 1232 va / 1611 va

See Light
Fixture Schedule

Equipment schedules with motors (not used for mechanical systems) NA

motor horsepower NA
 number of phases NA
 minimum efficiency NA
 motor type NA
 # of poles NA

DESIGNER STATEMENT

I hereby certify that the design of this building complies with the electrical systems, services systems, and equipment requirements of the 2012 North Carolina State Building Code, Energy Edition.

INTERIOR LIGHTING LOAD CALCULATIONS

PROJECT Washington Rest Area

AREA (sf)	WATTS	FIXTURES	FEET OF TRACK	WATTS
358 Lobby	0	0	0	0
828 Restroom	0	0	0	0
292 Electrical/Mechanical	0	0	0	0
92 Active Storage	0	0	0	0
562 Corridor/Transition	0	0	0	0
2132 TOTAL				

FIXTURE	WATTS PER	# INTERIOR FIXTURES	WATTS
A	40	10	400
B	64	6	384
C	12	11	132
D	20	11	220
F	96	1	96
TOTAL (w)			1232 SPECIFIED

ADDITIONAL (w)	ALLOWED (w/sf)	TOTAL (w)
0	0.80 Lobby	0
	0.84 Restroom	
	0.95 Electrical/Mechanical	
	0.63 Active Storage	
	0.65 Corridor/Transition	
	TOTAL (w)	1611 ALLOWED
		379 REMAINING

CONNECTED	TRACK (@ 75W/FT)	OTHER	TOTAL
	0	1232	1232
		1232	1232
		1543	1543
		128%	

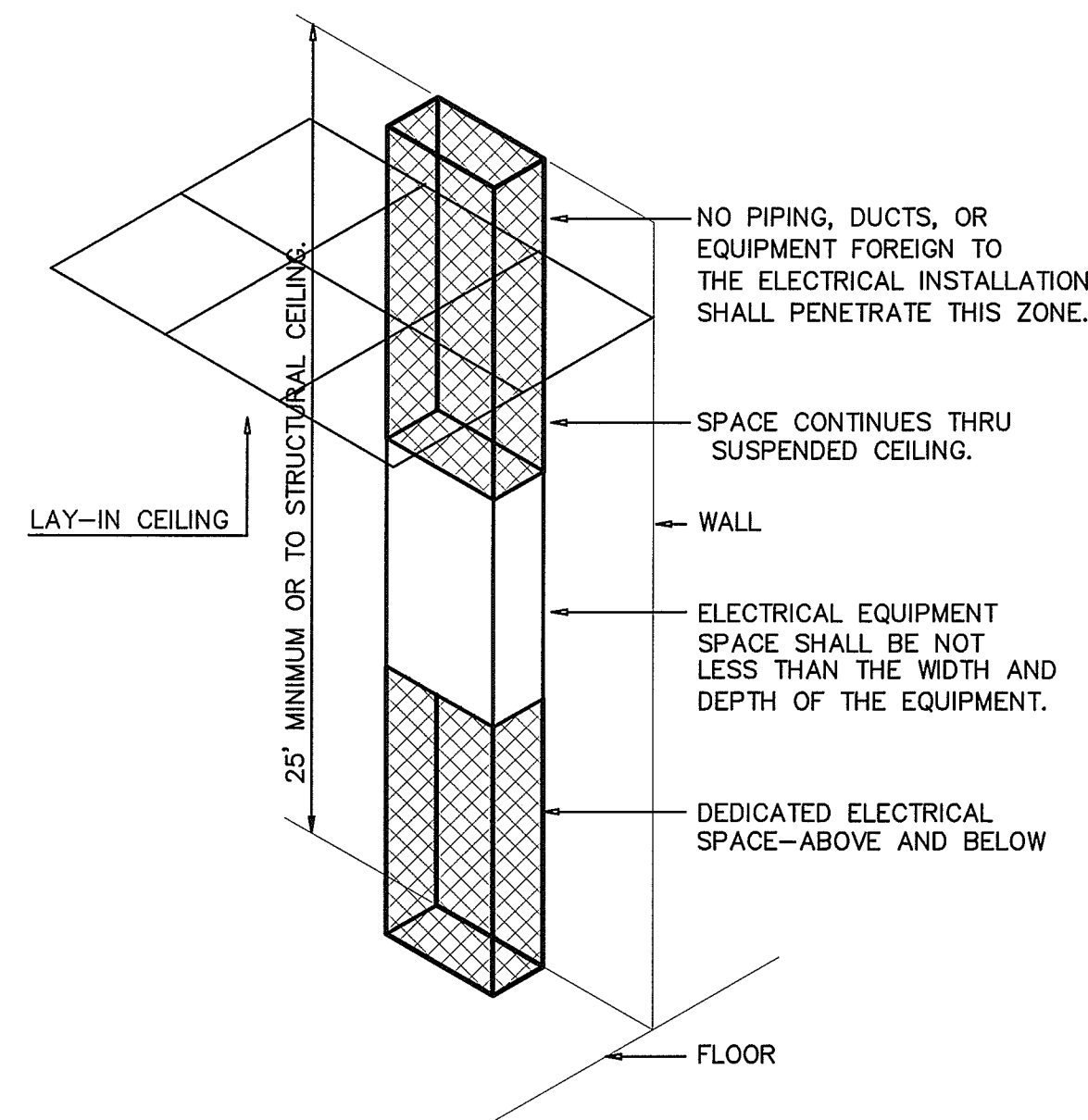

ELECTRICAL EQUIPMENT DEDICATED SPACE PER ARTICLE 110.26.F.1 OF N.E.C.

1 DEDICATED SPACE
 E1 SCALE: NOT TO SCALE

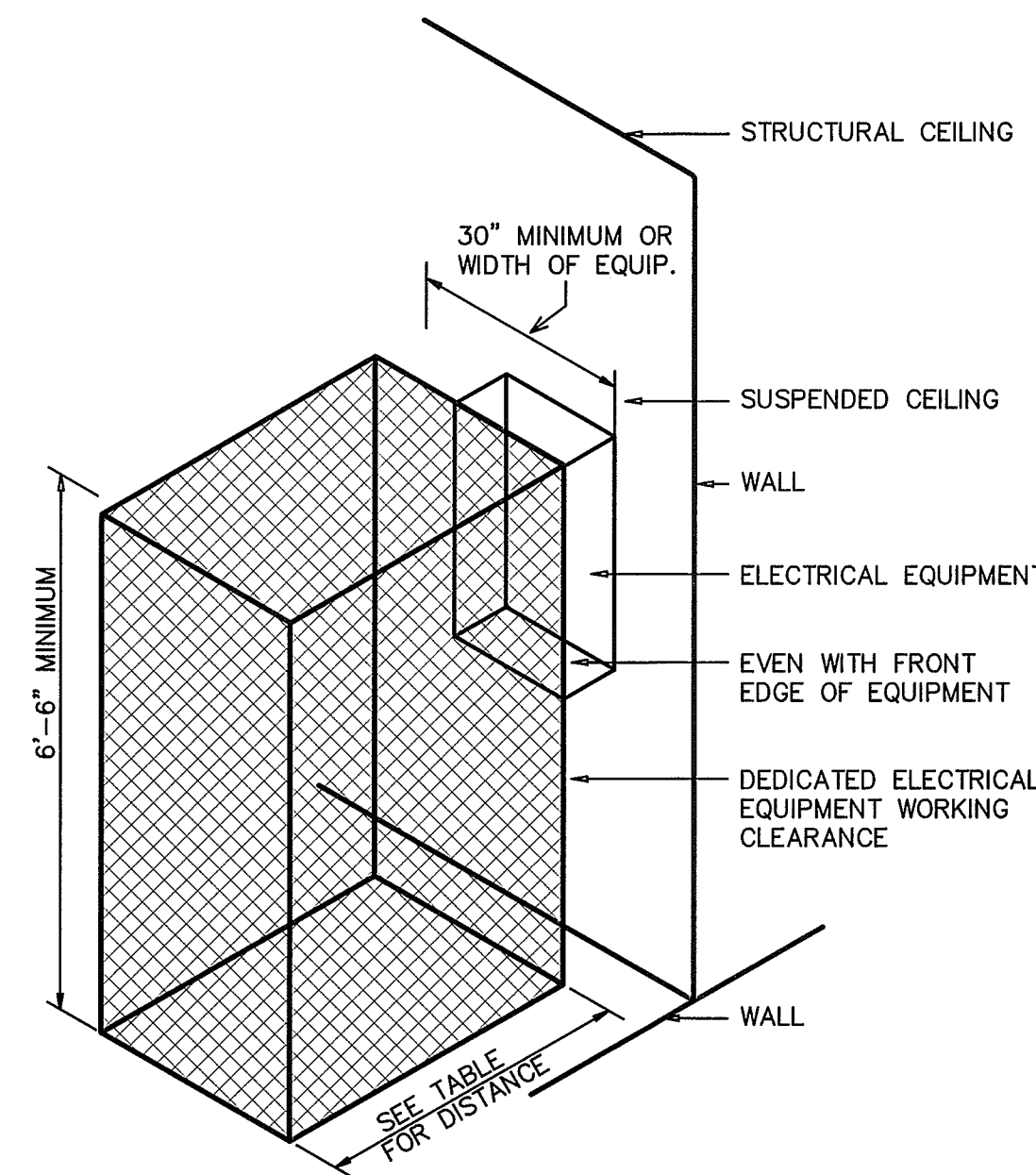

THIS FIGURE ILLUSTRATES THE WORKING SPACE IN FRONT OF THE ELECTRICAL EQUIPMENT REQUIRED BY SECTION 110.26 OF THE N.E.C.

2 ELECTRICAL CLEARANCES
 E1 SCALE: NOT TO SCALE

ELECTRICAL EQUIPMENT WORKING CLEARANCE PER ARTICLE 110.26 OF N.E.C.

VOLTAGE TO GROUND NOMINAL	WORKING CLEARANCES			
	MIN. CLEAR DISTANCE IN FEET			
	CONDITION:	1	2	3
0-150		3	3	3
151-600		3	3-1/2	4

WHERE THE CONDITIONS ARE AS FOLLOWS:

- EXPOSED LIVE PARTS ON ONE SIDE OF THE WORKING SPACE AND NO LIVE OR GROUNDED PARTS ON THE OTHER SIDE OF THE WORKING SPACE, OR EXPOSED LIVE PARTS ON BOTH SIDES OF THE WORKING SPACE THAT ARE EFFECTIVELY GUARDED BY INSULATING MATERIALS.
- EXPOSED LIVE PARTS ON ONE SIDE OF THE WORKING SPACE AND GROUNDED PARTS ON THE OTHER SIDE OF THE WORKING SPACE. CONCRETE, BRICK OR TILE WALLS SHALL BE CONSIDERED AS GROUNDED.
- EXPOSED LIVE PARTS ON BOTH SIDES OF THE WORK SPACE.

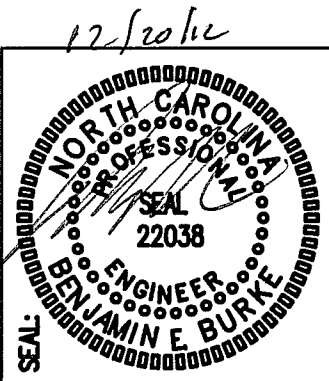

ENGINEER
EDU
 E. BENBURKE
 3305-108 Durham Drive
 Raleigh, North Carolina 27603
 919.771.1916 fax: 919.779.0826
 email: benburke@nc.rr.com
 Corp. License # C-2652

FACILITIES DESIGN
 ARCHITECTS & ENGINEERS
 FACILITIES MANAGEMENT DIVISION, NCDOT
 1 SOUTH WILMINGTON STREET
 RALEIGH, NORTH CAROLINA 27601
 919.771.0400 FAX: 919.771.0399



WASHINGTON COUNTY US-64
 REST AREA/VISITOR CENTER
 1248 US-64 EAST,
 PLYMOUTH, NC 27962

PROJECT:

TIP PROJ. NO. K-5000
 WBS NO. 41532.3.1
 CONTRACT ID NO.
 FEDERAL ID NO. NHS-0064(158)

REVISIONS	NO.	DATE

DATE ISSUED: 10/9/12
 DRAWN BY: WBT
 CHECKED BY: BEB

SHEET NO.
E1
 1 of 3

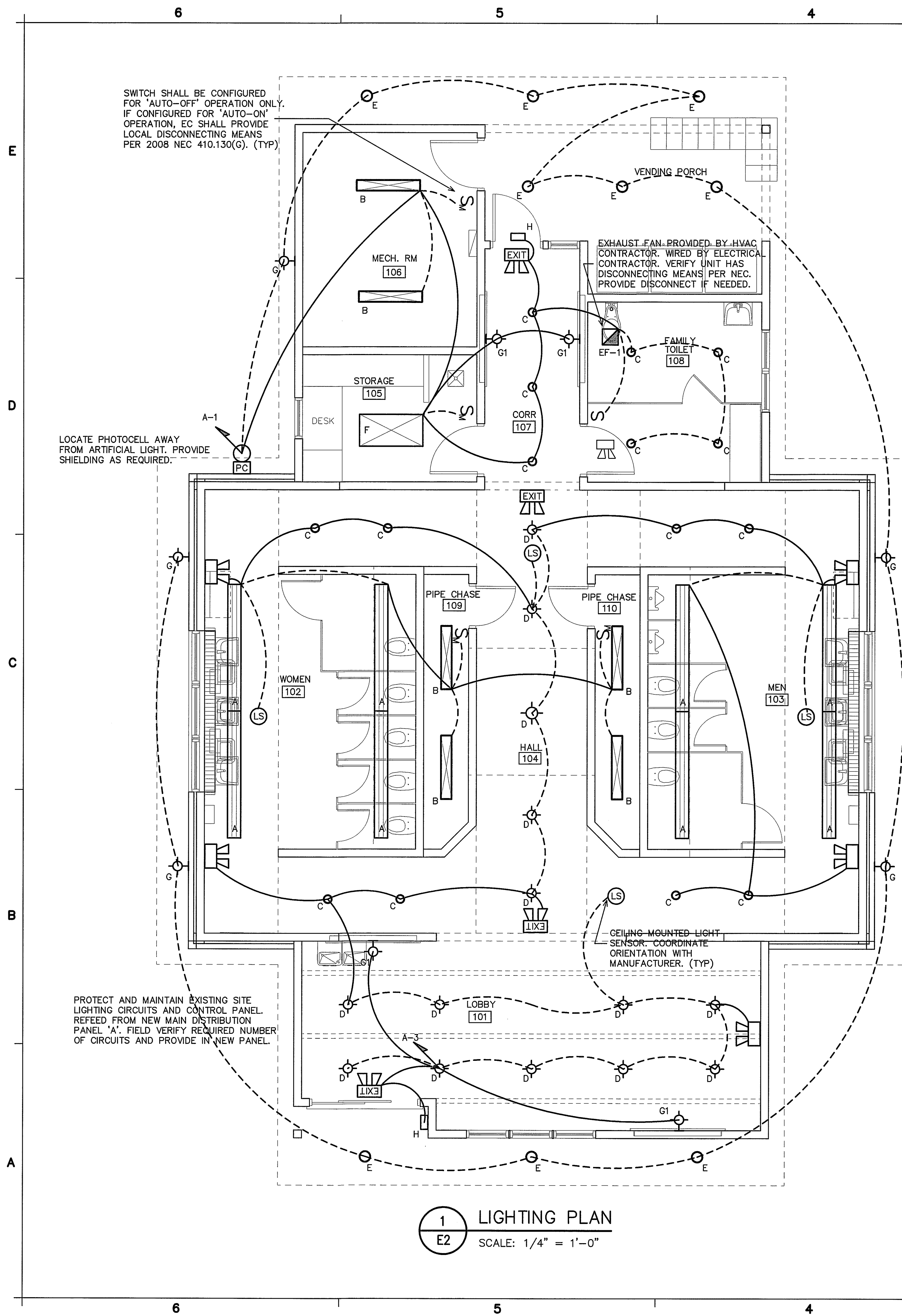

1 LIGHTING PLAN
E2 SCALE: 1/4" = 1'-0"

WASH E-2

FIXTURE SCHEDULE *

MARK	MANUFACTURER	CATALOG NO.	VOLT.	LAMPS			BALLAST TYPE	WATTS/FIXTURE	REMARKS
				NO.	TYPE	WATTS/LAMP			
A	CREE	CS18-40L-40K-10V	UNV	-	LED	-	-	40	1X8 LINEAR SURFACE SUSPENDED LED
B	DAY-BRITE	T232-UNV-1/2-EB-TSR4-C173	UNV	2	T8	32	EB	64	48" DUAL LAMP STRIP WITH REFLECTOR, WIRE GUARD **
C	JUNO	IC22LEDG3-35K-U-27B-WH	UNV	-	LED	-	-	12	6" RECESSED CAN, OPEN TRIM
D	JOHN TIMBERLAND	V1687	120	7	LED	4	-	28	PENDANT, 7" DIAMETER, 13" HIGH, BRONZE FINISH
E	INDY	L6-17351-L600H-CQ	120	-	LED	-	-	23	EXTERIOR 6" RECESSED CAN, OPEN REFLECTOR **
F	DAY-BRITE	2SMR332-FS01-UNV-1/3	UNV	3	T8	32	EB	96	2X4 SURFACE MODULAR, PRISMATIC ACRYLIC LENS
G	JOHN TIMBERLAND	V1684	120	7	LED	4	-	28	EXTERIOR DECORATIVE LED WALL SCONCE, 13 1/2" HIGH.
G1	JOHN TIMBERLAND	V1685	120	7	LED	4	-	28	DECORATIVE LED WALL SCONCE, 10 1/2" HIGH.
H	MCPHILBEN	PDNB	120	2	HAL	6	-	12	EXTERIOR EMERGENCY LIGHT, BLACK HOUSING
EXIT	MCPHILBEN	CCTXL1RW	120	2	COMB	5.4	-	12	COMBINATION EMERGENCY (HALOGEN) / EXIT (LED) LIGHT
EXIT	MCPHILBEN	CTX6L12WCSWA	120	2	TUNG	5.4	-	10.8	EMERGENCY LIGHT

* OR APPROVED EQUAL. PROVIDE CUT SHEETS FOR OWNER APPROVAL PRIOR TO ORDERING FIXTURES. FOR FLUORESCENT FIXTURES CONTROLLED BY MOTION SENSOR, PROVIDE "PROGRAMMED RAPID START" BALLASTS. CATALOG NUMBERS ARE FOR REFERENCE ONLY. ACTUAL NUMBERS MAY VARY. 'EB' DENOTES ELECTRONIC BALLAST.

** VERIFY FIXTURE HAS INTEGRAL LOCAL DISCONNECTING MEANS PER NEC 410.130 (G) (2008).

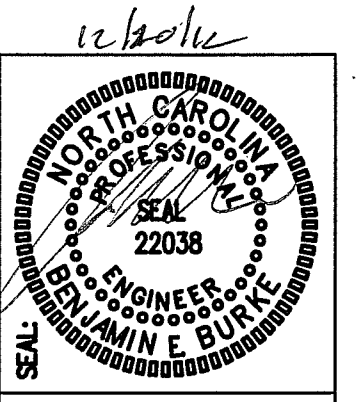
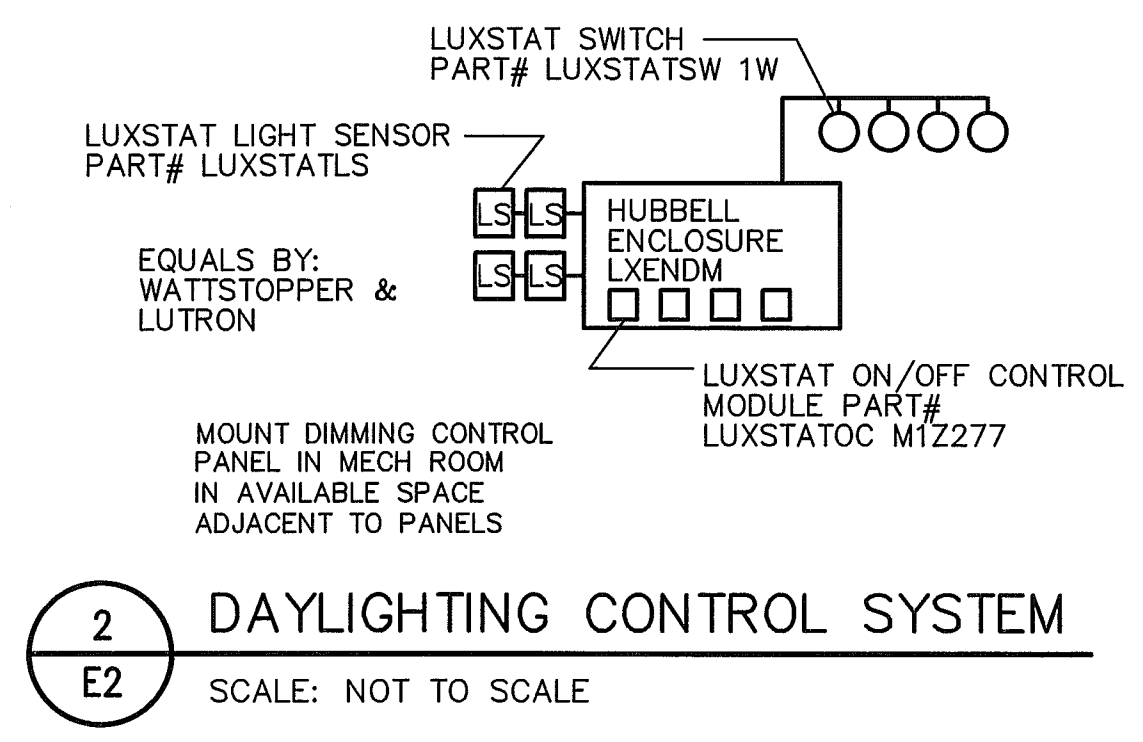

ENGINEER
BUREAU DESIGN GROUP, P.A.
3305-108 Durham Drive
Raleigh, North Carolina 27603
919.771.1916 fax: 919.779.0828
email: benburke@ncr.com
Corp. License # C-2652

BDU

FACILITIES DESIGN
ARCHITECTS & ENGINEERS
FACILITIES MANAGEMENT DIVISION, NCDOT
1 SOUTH WILMINGTON STREET
WILMINGTON, NORTH CAROLINA 27401
919.776-0400 FAX: 919.716-0399



PROJECT:
WASHINGTON COUNTY US-64 REST AREA VISITOR CENTER
1248 US-64 EAST, PLYMOUTH, NC 27962

TIP PROJ. NO.	K-5000
WBS NO.	41532.3.1
CONTRACT ID NO.	
FEDERAL ID NO.	NHS-0064(158)

REVISIONS	
NO.	DATE

DATE ISSUED: 10/9/12
DRAWN BY: WBT
CHECKED BY: BEB
SHEET NO.

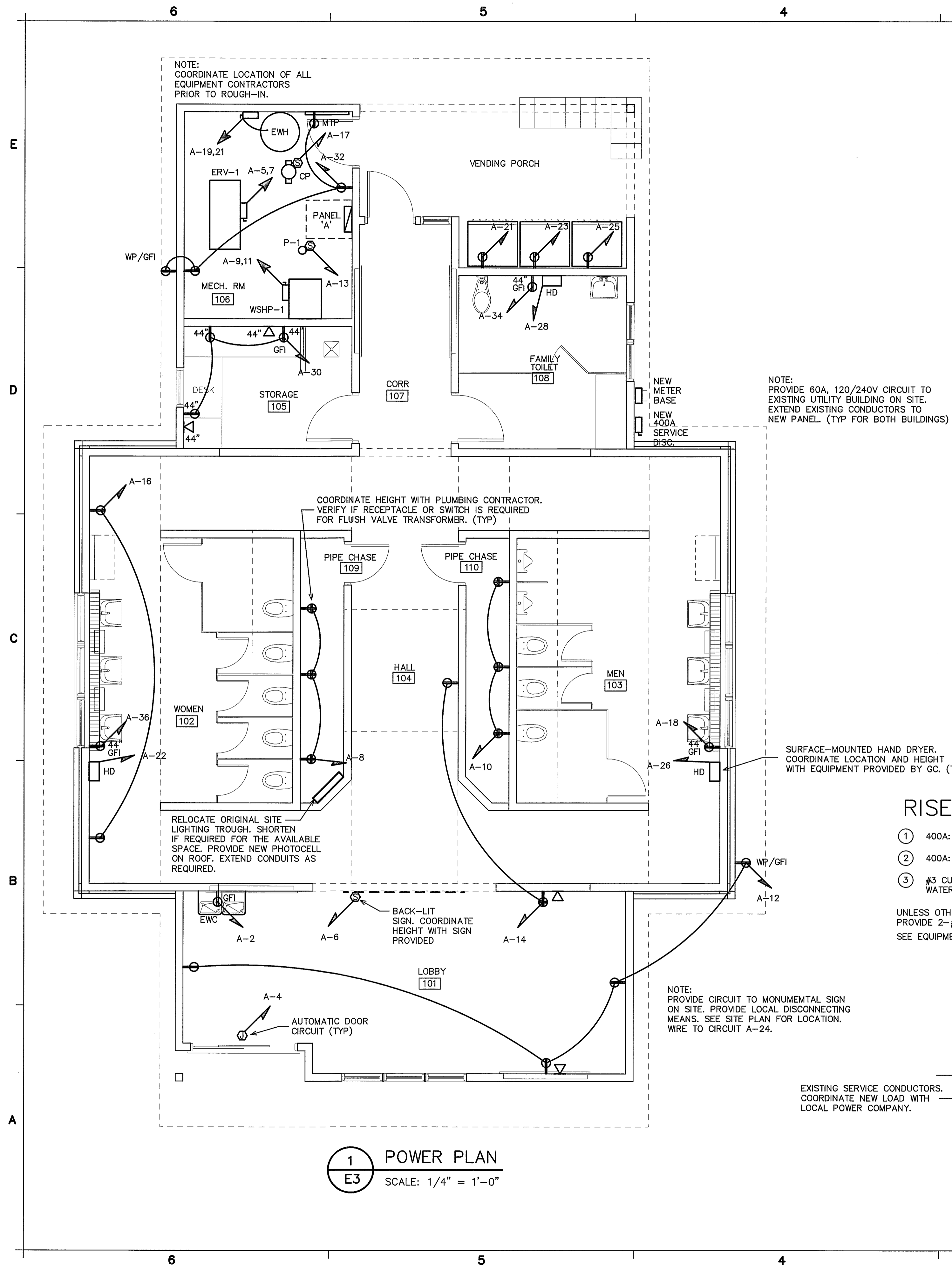

1 POWER PLAN
E3 SCALE: 1/4" = 1'-0"

WASH E-3
NEW PANEL- 'A'
FED FROM: 400A SERVICE

MAKE: CUTLER HAMMER
TYPE: CH LOAD CENTER
OR APPROVED EQUAL

RATING: 120/240V 1 PHASE 3 WIRE
MOUNTING: SURFACE
MINIMUM AIC: VERIFY

400A MAIN CIRCUIT BREAKER
EQUIPMENT GROUND BUS YES NO
SERVICE ENTRY RATED YES NO

LOAD SERVICE	CKT BRKR	WATTS PER PHASE		CKT NO	NEUTRAL		WATTS PER PHASE		CKT BRKR	LOAD SERVICE	
		A	B		A	B	A	B			
LTS: 105-108, EXTERIOR	20A	925		1			2	888		20A EWC	
LTS: 101-104, 109, 110	20A		892	3			4	600		AUTOMATIC DOOR	
ERV-1	15A	1224		5			6	600		INTERIOR SIGN	
10.2 FLA			1224	7			8	300		FLUSH VALVE CONTROLS	
WSHP-1	50A	3288		9			10	300		FLUSH VALVE CONTROLS	
FAN 6.9 FLA, COMP 20.5 RLA			3288	11			12	720		REC: 101, EXTERIOR	
P-1 (0.4 HP)	20A	989		13			14	540		REC: 101, 104	
SOLAR PUMP	20A		540	15			16	360		REC: 102	
CIRCULATION PUMP 0.8 FLA	20A	96		17			18	360		REC: 103	
EWH	30A		2880	19			20	---		SPARE	
VENDING MACHINE	20A	1000		21			22	2300		HAND DRYER	
VENDING MACHINE			1000	23			24	1200		SIGN CIRCUIT	
VENDING MACHINE			1000	25			26	2300		HAND DRYER	
SITE LIGHTING (EXISTING)			1920	27			28	2300		HAND DRYER	
SITE LIGHTING (EXISTING)			1920	29			30	540		REC: 105	
SITE LIGHTING (EXISTING)			1920	31			32	360		REC: 106	
SITE LIGHTING (EXISTING)			1920	33			34	360		REC: 108	
UTILITY/STORAGE BUILDING (EXISTING)	60A		3600	35			36	500		AUTOMATIC FAUCETS	
SPARE	20A	---	---	39			40	---		SPARE	
SPARE	20A	---	---	41			42	---		SPARE	
NOTES		SUB-TOTALS 'B'		15962	17264	400A BUS		8188	6540	SUB-TOTALS 'A'	
GFCI BREAKERS		400A LUGS		15962	17264	SUB-TOTALS 'B'				TOTAL CONNECTED LOAD	
HACR BREAKERS		400A FEED		24150	23804	GRAND TOTAL					
		VERIFY SIZE		201A	198A	AMPS/PHASE					

NEC ALLOWABLE DEMAND FACTORS

- DEMAND FACTORS PER NEC 220
- LARGEST OF: NEC TABLE 220.12 OR CONNECTED LOAD
- NEC TABLE 220.56
- NEC 220.51
- NEC 220.43A, 200 VA/LINEAR FT
- NON-COINCIDENT LOADS, LARGEST OF THE TWO LOADS IS COUNTED

② 2132 SQ.FT. X 2.0 W/SQ.FT. X 125% = 5330 VA

DIVERSIFIED LOAD SUMMARY

LOAD TYPE	DEMAND FACTOR	A	B	TOTAL DIVERSIFIED LOAD
GENERAL LIGHTING	② 125%	2665	2665	5330
SITE LIGHTING	125%	4800	4800	9600
GENERAL USE RECEPTACLES	③ ≤10KVA@100% ④ >10KVA@50%	1800	1440	3240
MOTORS AND EQUIPMENT	⑤ LARGEST 125% ⑥ ALL OTHERS 100%	3075	3075	6150
WATER HEATERS	125%	---	3600	3600
KITCHEN EQUIPMENT	④ 100%	---	---	---
FIX. ELEC. SPACE HEAT.	④ 100%	---	---	---
SHOW WINDOW LIGHTS	⑥ 125%	---	---	---
SIGN	125%	---	---	---
MISC	100%	---	---	---
PHASE (TOTAL VA)		27597	27872	55469
TOTAL AMPS		230A	232A	55469 VOLTS = 231A TOTAL AMPS

RISER WIRING SCHEDULE

- 400A: 3-#600MCM IN 3" CONDUIT
 - 400A: 3-#600MCM, 1-#3 CU GND, IN 3 1/2" CONDUIT
 - #3 CU GND TO BUILDING STEEL, FOUNDATION STEEL AND METALLIC WATER MAIN AND #6 CU GND TO 10' X 5/8" DRIVEN GROUND ROD
- UNLESS OTHERWISE NOTED ALL OTHER CIRCUITS ARE 20A, 120VOLT. PROVIDE 2-#12, 1-#12 CU GND IN 1/2" CONDUIT. SEE EQUIPMENT SCHEDULES FOR ADDITIONAL WIRE SIZES.

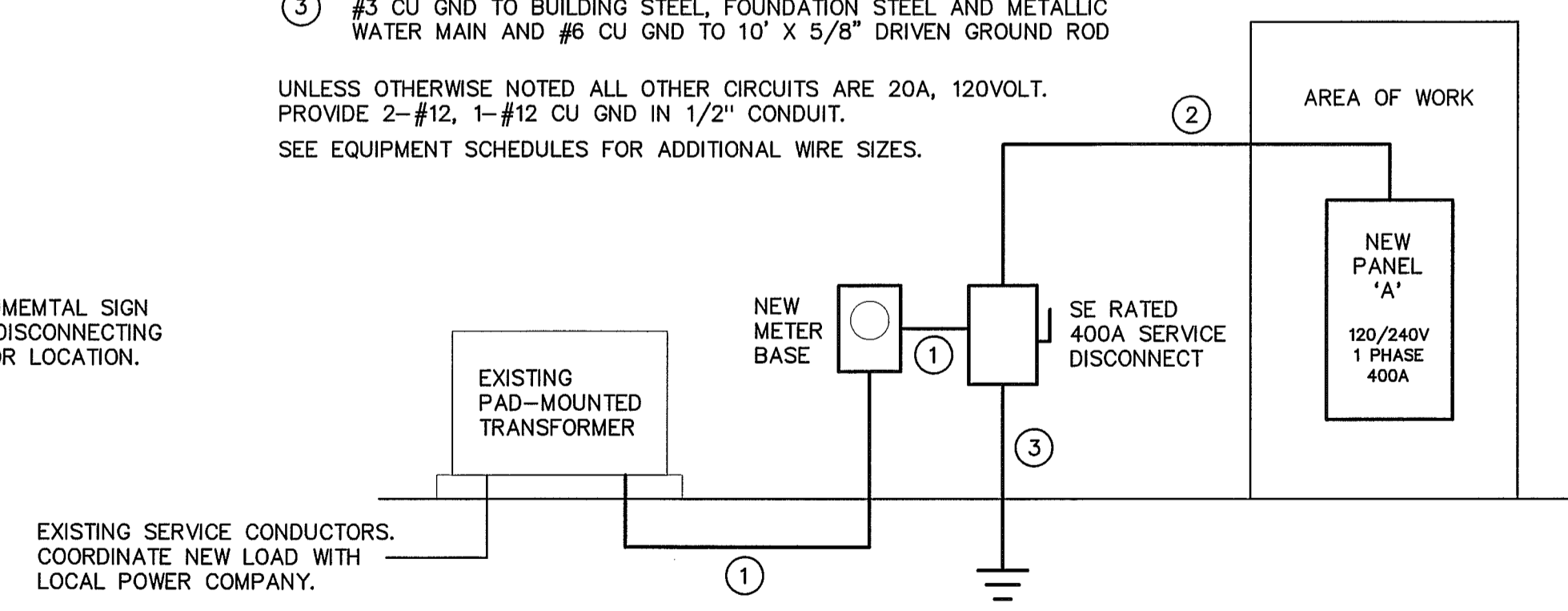

2 RISER DIAGRAM
E3 SCALE: NOT TO SCALE

WASH E-3
EQUIPMENT WIRING SCHEDULE

EQUIPMENT	MCA	MOCP	VOLTS	PH	WIRE SIZE
ERV-1	11.5A	15A	240V	1	2-#12, 1-#12 GND IN 1/2" CONDUIT
EWH	---	30A	120V	1	2-#10, 1-#10 GND IN 1/2" CONDUIT
WSHP-1	33.0A	50A	240V	1	2-#8, 1-#10 GND IN 3/4" CONDUIT

THE EC SHALL VERIFY ALL EQUIPMENT ELECTRICAL REQUIREMENTS INCLUDING VOLTAGE, PHASE AND AMPERAGE PRIOR TO ROUGH-IN AND RELEASING GEAR. ADJUST BREAKER, WIRE SIZES, ETC. AS REQUIRED.

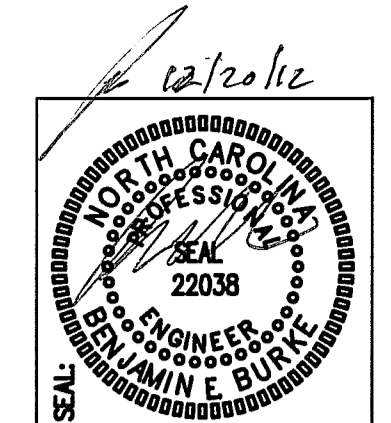

ENGINEER
BURKE DESIGN GROUP, PA
3305 108th Drive
Raleigh, North Carolina 27603
919 771 1918 fax 919 779 0826
email: burkengr@bdcg.com
Lic. License # C-2652

FACILITIES DESIGN
ARCHITECTS & ENGINEERS
FACILITIES MANAGEMENT DIVISION, NCDOT
1 SOUTH WILMINGTON STREET
RALEIGH, NORTH CAROLINA 27601
919/715-0400 FAX: 919/715-0399



PROJECT:
WASHINGTON COUNTY US-64 REST AREA/VISITOR CENTER
1248 US-64 EAST, PLYMOUTH, NC 27962

TIP PROJ. NO. K-5000
WBS NO. 41532.3.1
CONTRACT ID NO.
FEDERAL ID NO. WHS-0064(158)

REVISIONS NO.	DATE

DATE ISSUED: 10/9/12
DRAWN BY: WBT
CHECKED BY: BEB

SHEET NO.
E3
3 of 3

6

5

4

3

2

1

GENERAL NOTES

- 1) CONTRACTOR TO FIELD VERIFY ALL EXISTING UTILITIES PRIOR TO COMMENCING CONSTRUCTION.
- 2) CONTRACTOR IS RESPONSIBLE FOR DISPOSAL OF ALL WASTE MATERIALS GENERATED THROUGH ALL CONSTRUCTION RELATED ACTIVITIES.
- 3) CONTRACTOR SHALL PROVIDE PROPER SEDIMENT/EROSION CONTROL AND TREE PROTECTION FENCING AS REQUIRED.

COORDINATE WORK WITH ALL TRADES PER NCDOT STANDARD SPECIFICATIONS FOR ROADS AND STRUCTURES. CONTRACTOR IS RESPONSIBLE FOR MAINTAINING ALL LINES IN WORKING CONDITION UPON COMPLETION OF WORK. LANDSCAPE WORK, POST TOP/ROADWAY LIGHT HEAD REPLACEMENT TO BE UNDER SEPARATE CONTRACT.

NOTE:
ALL SITE UTILITY WORK ON SHEETS U-1 AND U-2 WILL BE PAID FOR UNDER THEIR RESPECTIVE LUMP SUM PAY ITEMS FOR PLUMBING INSTALLATION REST AREA SERVICE BUILDING, HVAC INSTALLATION REST AREA SERVICE BUILDING, AND ELECTRICAL INSTALLATION REST AREA SERVICE BUILDING. NO SEPARATE LINE ITEMS ARE INCLUDED IN THIS PROJECT FOR SITE UTILITY WORK. COORDINATE WORK WITH ALL TRADES .

- KEY NOTES FOR SHEET U1
- 1) PROVIDE CLEANOUT AT FINISH GRADE (COFG) ON EXISTING SEWER LINE TO REMAIN ACTIVE AT BUILDING EXTERIOR.
 - 2) EXISTING 4" SEWER MAIN TO REMAIN IN PLACE. THE PLUMBING CONTRACTOR SHALL EXTEND TO 5'-0" OUTSIDE OF BUILDING AND PROVIDE (COFG) CLEAN-OUT AT FINISH GRADE.
 - 3) CONNECT NEW 3" WATER LINE (SCHEDULE 80 PVC) TO EXISTING POTABLE WATER MAIN AND PROVIDE VALVE IN VALVE BOX. INSTALL LINE TO BUILDING. TIE INTO EXISTING COPPER 3" WATER MAIN WHERE IT ENTERS THE BUILDING.
 - 4) NEW WATER SHUT-OFF VALVE IN BOX. SEE DETAIL SHEET U-3.
 - 5) EXISTING SERVICE TRANSFORMER TO REMAIN. COORDINATE NEW BUILDING LOADS WITH LOCAL POWER COMPANY.
 - 6) REMOVE EXISTING UNDERGROUND SERVICE CONDUCTORS AND METER BASE.
 - 7) PROVIDE NEW 400A UNDERGROUND SERVICE CONDUCTORS TO NEW METER BASE AND SERVICE DISCONNECT. SEE SHEET E-4.
 - 8) MAINTAIN AND EXTEND THE ELECTRICAL SERVICE LINE TO THE EXISTING STORAGE BUILDING AS REQUIRED.
 - 9) EXISTING SITE LIGHTS TO REMAIN ENERGIZED. (TYPICAL)
 - 10) GROUND SOURCE HEAT PUMP WELLS ON 20'-0" CENTERS SEE 4/M-2 FOR REQUIREMENTS.
 - 11) TELEPHONE PEDESTAL TO REMAIN

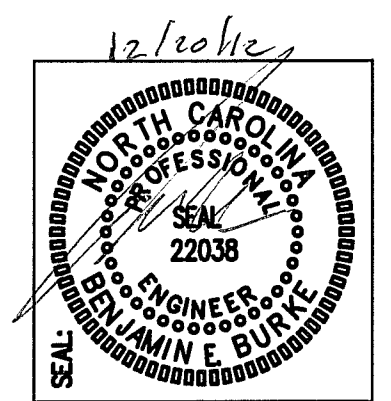
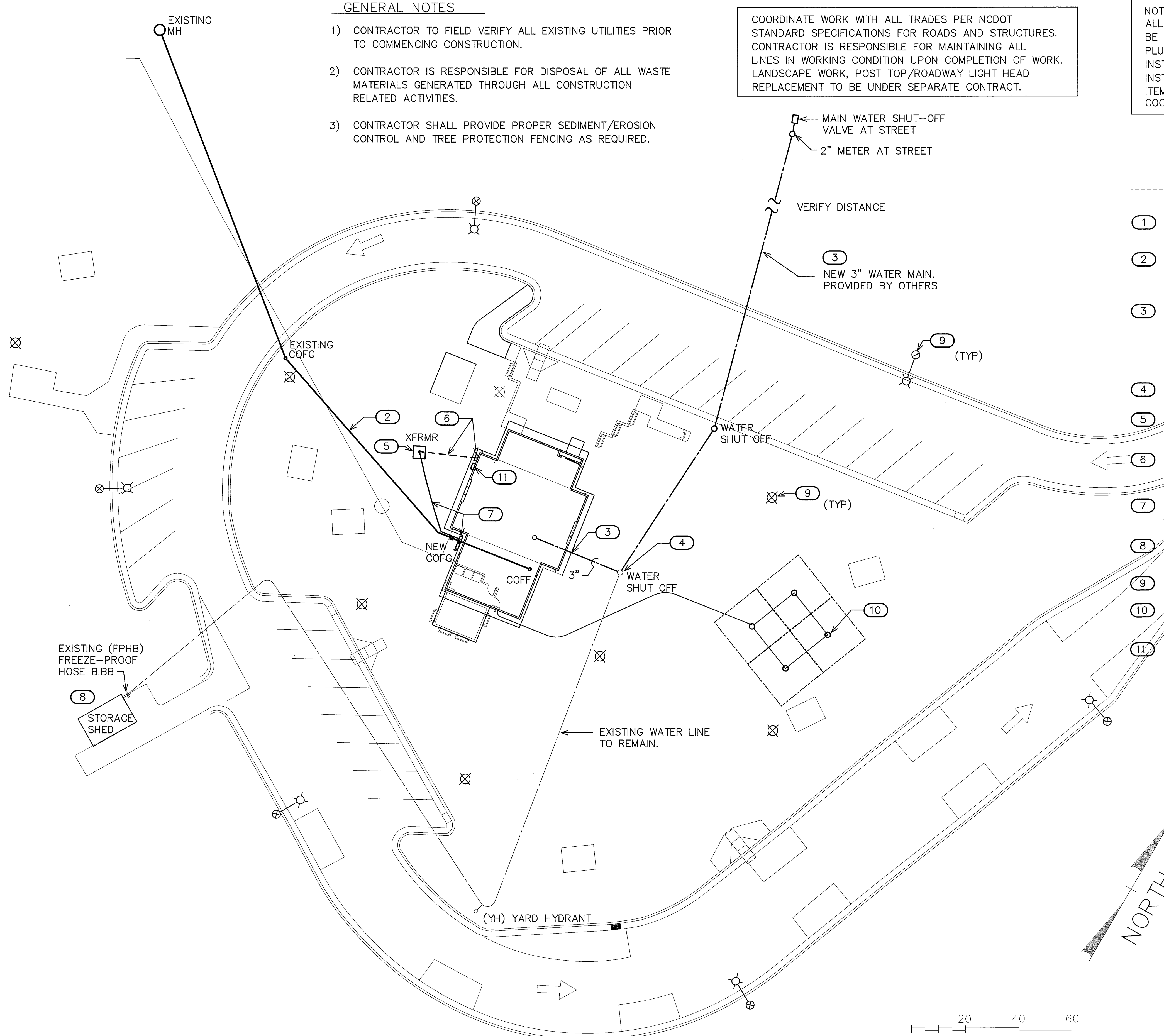

ENGINEER
BURKE DESIGN GROUP, PA
 3305-108 Durham Drive
 Raleigh, North Carolina 27603
 919.771.1916 fax: 919.779.0826
 email: benburke@bdcg.com
 Corp. License # C-2652

FACILITIES DESIGN
 ARCHITECTS & ENGINEERS
 FACILITIES MANAGEMENT DIVISION, NCDOT
 1 SOUTH WILMINGTON STREET
 RALEIGH, NORTH CAROLINA 27601
 919.715-0400 FAX: 919.715-0389



PROJECT:
WASHINGTON COUNTY US-64
REST AREA/VISITOR CENTER
 1248 US-64 EAST,
 PLYMOUTH, NC 27962

TIP PROJ. NO. K-5000
 WBS NO. 41532.3.1
 CONTRACT ID NO.
 FEDERAL ID NO. NWS-0064(158)

REVISIONS NO.	DATE

DATE ISSUED: 12/12/12
 DRAWN BY: BEB
 CHECKED BY: BEB

SHEET NO.
U1
 1 of 2

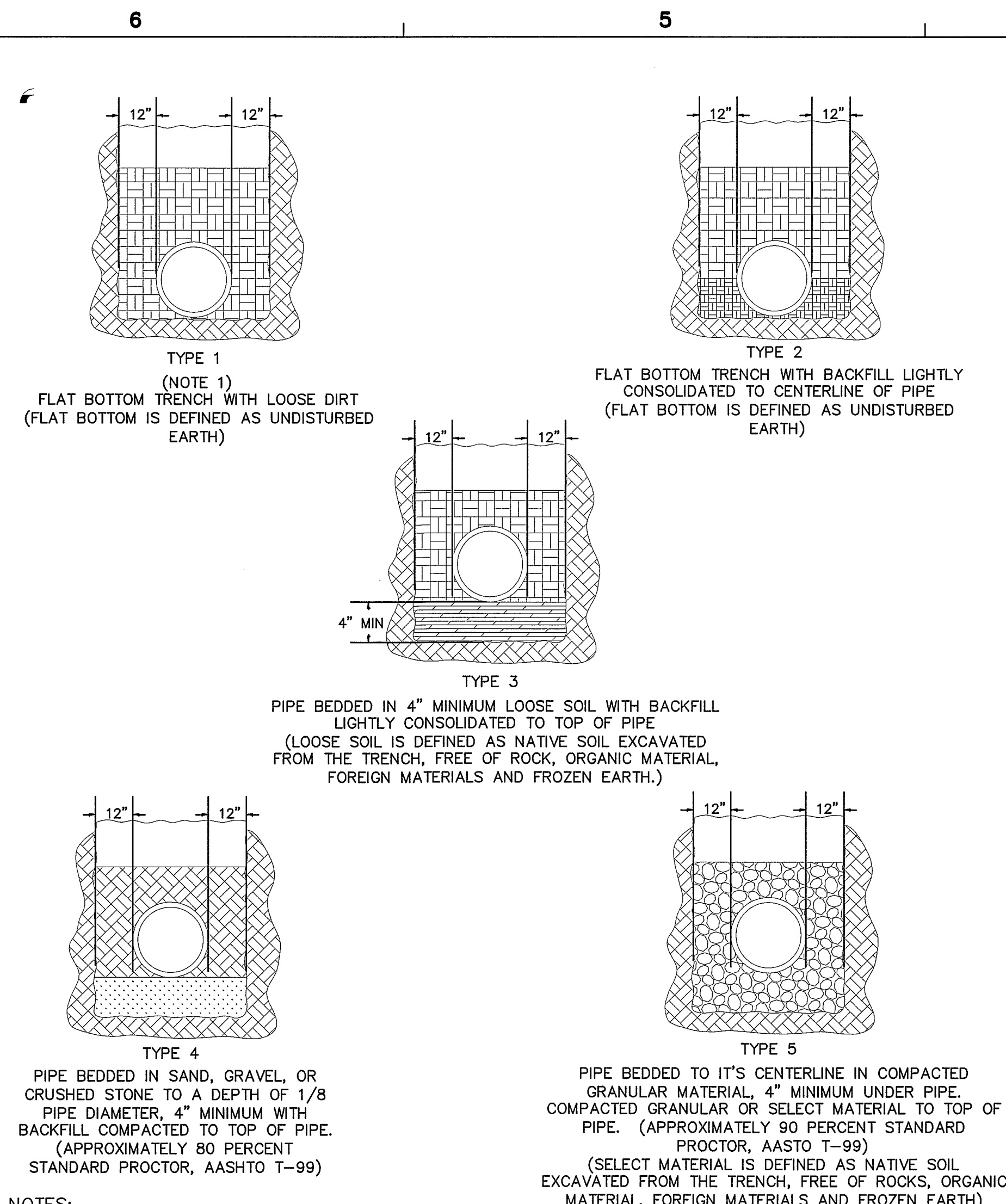

NOTES:

- FOR NORMAL PIPE SIZES 14 INCH AND LARGER, CONSIDERATION SHOULD BE GIVEN TO THE USE OF LAYING CONDITIONS OTHER THAN TYPE 1.
- CONSIDERATION OF THE PIPE-ZONE EMBEDMENT CONDITIONS INCLUDED IN THIS FIGURE MAY BE INFLUENCE BY FACTORS OTHER THAN PIPE STRENGTH. FOR ADDITIONAL INFORMATION ON PIPE BEDDING AND BACKFILL, SEE ANSI/AWWA C600.

UTILITY SEPARATION NOTES

- LATERAL SEPARATION OF SEWERS OR WATER MAINS. WATER MAINS SHALL BE LAID AT LEAST TEN (10) FEET Laterally FROM EXISTING OR PROPOSED SEWERS, UNLESS LOCAL CONDITIONS OR BARRIERS PREVENT A TEN (10) FOOT LATERAL SEPARATION--IN WHICH CASE:
 - THE WATER MAIN IS LAID IN A SEPARATE TRENCH, WITH THE ELEVATION ON THE BOTTOM OF THE WATER MAIN AT LEAST EIGHTEEN (18) INCHES ABOVE THE TOP OF SEWER; OR
 - THE WATER MAIN IS LAID IN THE SAME TRENCH AS THE SEWER WITH THE WATER MAIN LOCATED AT ONE SIDE ON A BENCH OF UNDISTURBED EARTH, AND WITH THE ELEVATION OF THE BOTTOM OF THE WATER MAIN AT LEAST EIGHTEEN (18) INCHES ABOVE THE TOP OF SEWER.
- CROSSING A WATER MAIN OVER A SEWER. WHENEVER NECESSARY FOR A WATER MAIN TO CROSS OVER A SEWER, THE WATER MAIN SHALL BE LAID AT SUCH AN ELEVATION THAT THE BOTTOM OF THE WATER MAIN IS AT LEAST EIGHTEEN (18) INCHES ABOVE THE TOP OF THE SEWER, UNLESS LOCAL CONDITIONS OR BARRIERS PREVENT AN EIGHTEEN (18) INCH SEPARATION--IN WHICH CASE, BOTH THE WATER MAIN AND SEWER SHALL BE CONSTRUCTED OF FERROUS MATERIALS AND WITH JOINTS THAT ARE EQUIVALENT TO WATER MAIN STANDARDS FOR A DISTANCE OF TEN (10) FEET ON EACH SIDE OF THE CROSSING.
- CROSSING A WATER MAIN UNDER A SEWER. WHENEVER IT IS NECESSARY FOR A WATER MAIN TO CROSS UNDER A SEWER, BOTH THE WATER MAIN AND THE SEWER SHALL BE CONSTRUCTED OF FERROUS MATERIALS AND WITH JOINTS EQUIVALENT TO WATER MAIN STANDARDS FOR A DISTANCE OF THE (10) FEET ON EACH SIDE OF THE POINT(S) OF CROSSING. A SECTION OF WATER MAIN PIPE SHALL BE CENTERED AT THE POINT OF CROSSING.
- SEWER AND STORMWATER PIPES TO HAVE A MINIMUM OF 24" SEPARATION FROM BOTTOM OF STORMWATER PIPE AND TOP OF SEWER PIPE.

APPROVED METHOD FOR EXTENSION OF VALVE BOX

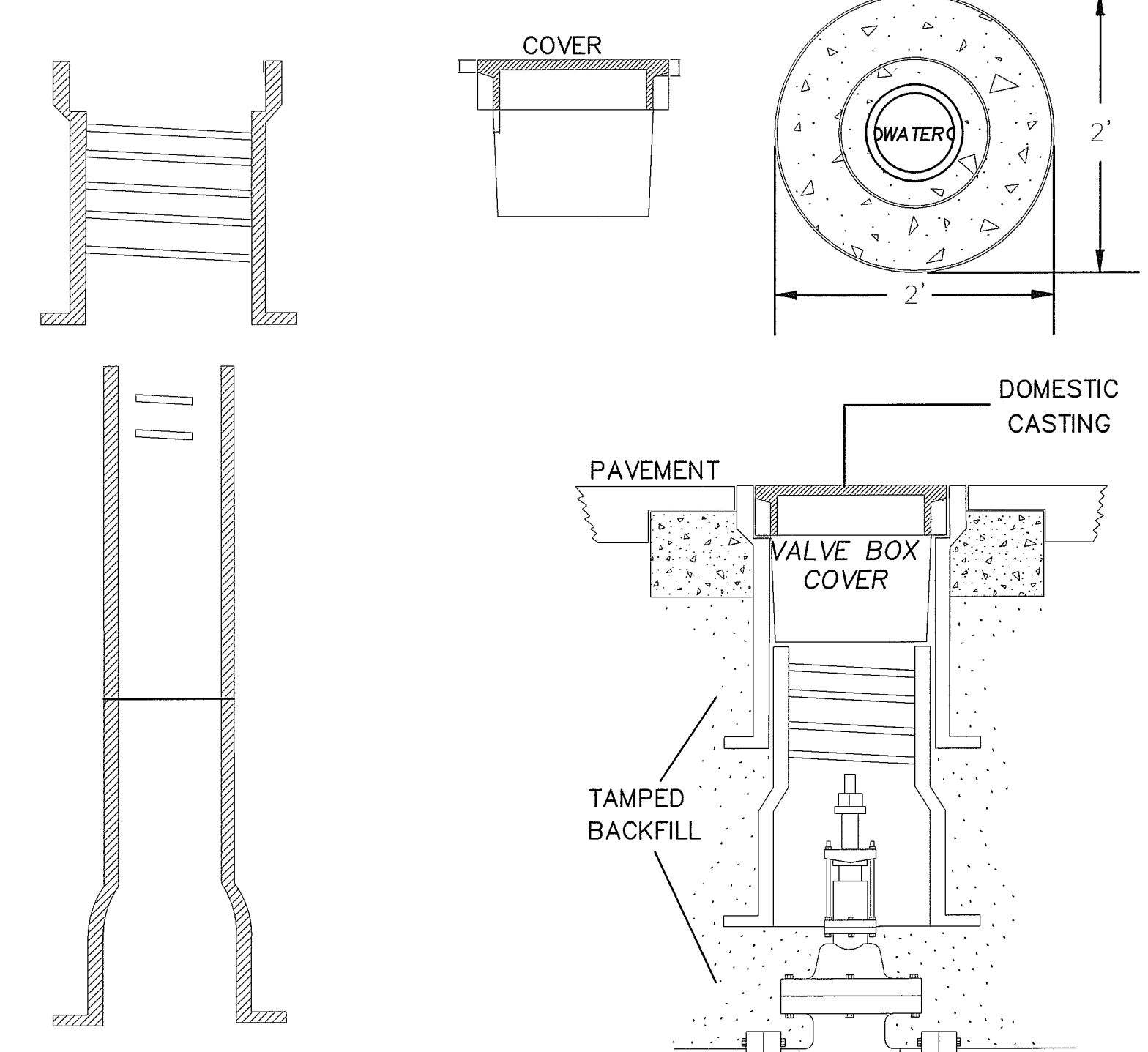

NOTE: VALVE BOX NOT TO CONTACT WATER MAIN NOR VALVE. ALL TRAFFIC CASTINGS MUST BE CLASS 35 OR GREATER DOMESTICALLY CAST. VALVE BOX SHALL BE THREADED TYPE.

SCALE: NOT TO SCALE

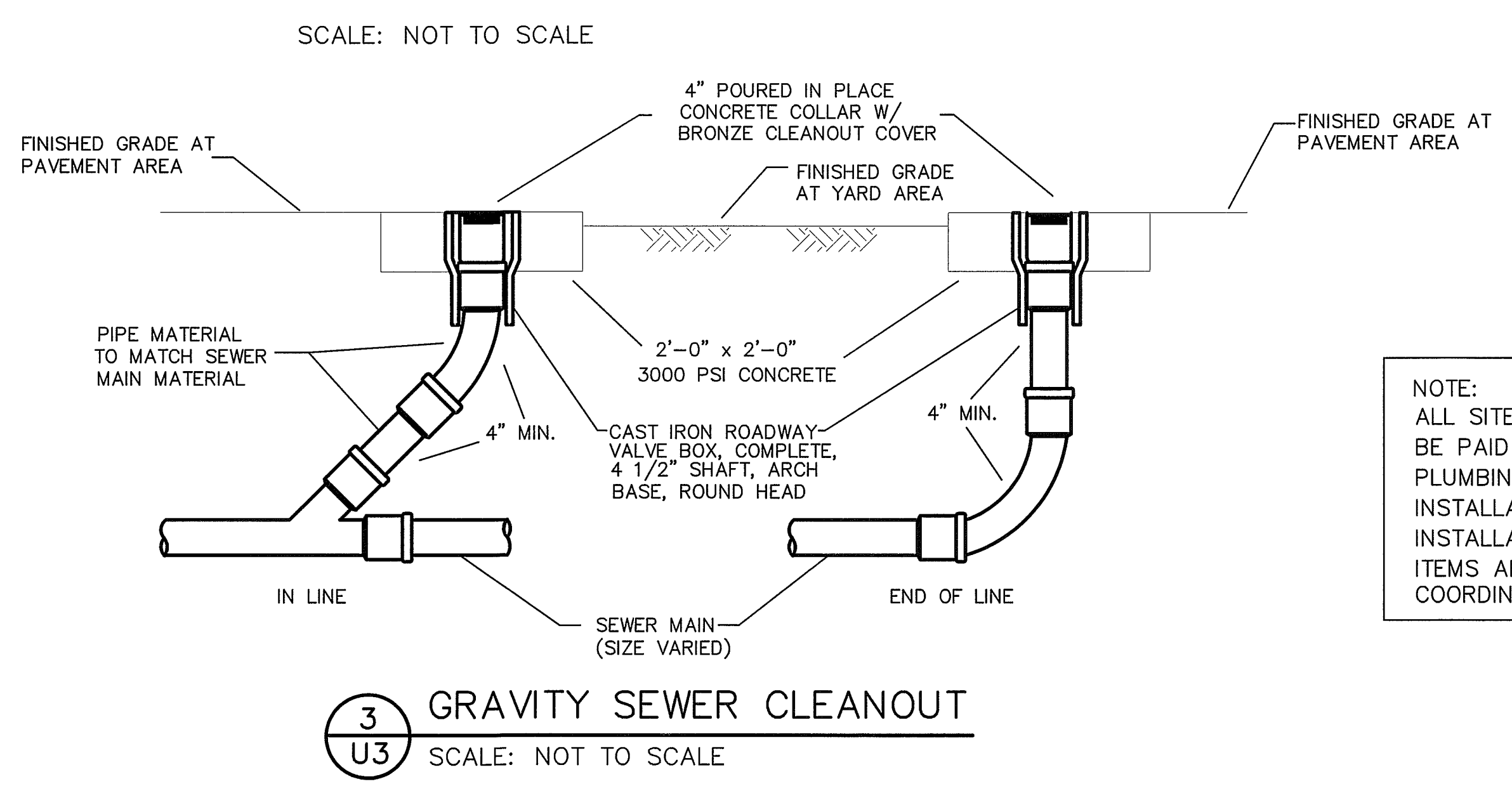

NOTE:
ALL SITE UTILITY WORK ON SHEETS U-1 AND U-2 WILL BE PAID FOR UNDER THEIR RESPECTIVE LUMP SUM PAY ITEMS FOR PLUMBING INSTALLATION REST AREA SERVICE BUILDING, HVAC INSTALLATION REST AREA SERVICE BUILDING, AND ELECTRICAL INSTALLATION REST AREA SERVICE BUILDING. NO SEPARATE LINE ITEMS ARE INCLUDED IN THIS PROJECT FOR SITE UTILITY WORK. COORDINATE WORK WITH ALL TRADES.

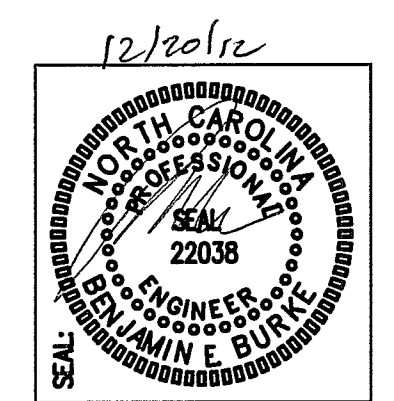

ENGINEER
BURKE DESIGN GROUP, PA
Benjamin R. Burke, P.E.
3305 109th Drive
Raleigh, North Carolina 27603
919.771.1916 fax: 919.779.0826
email: benburke@ncr.com
Corp. License # C-2652

FACILITIES DESIGN
ARCHITECTS & ENGINEERS
FACILITIES MANAGEMENT DIVISION, NCDOT
1 SOUTH WILMINGTON STREET
RALEIGH, NORTH CAROLINA 27601
919.775-0400 FAX: 919.775-0399



WASHINGTON COUNTY US-64
REST AREA VISITOR CENTER
1248 US-64 EAST,
PLYMOUTH, NC 27962

PROJECT:

TIP PROJ. NO.	K-5000
WBS NO.	41532.3.1
CONTRACT ID NO.	
FEDERAL ID NO.	NHS-0064(158)
REVISIONS	
NO.	DATE
DATE ISSUED: 12/12/12	
DRAWN BY: BEB	
CHECKED BY: BEB	
SHEET NO.	
U2	
2 of 2	